

FREE INSIDE! BLUE PRINT OF THE LONG-RANGE EXPRESS THREE

# Practical Wireless

3<sup>d</sup>

Published by

**GEORGE  
NEWNES  
LTD.**

Vol. 1 ————— No. 1

SEPTEMBER 24th, 1932

**THE VERY LATEST FOR  
THE HOME CONSTRUCTOR**

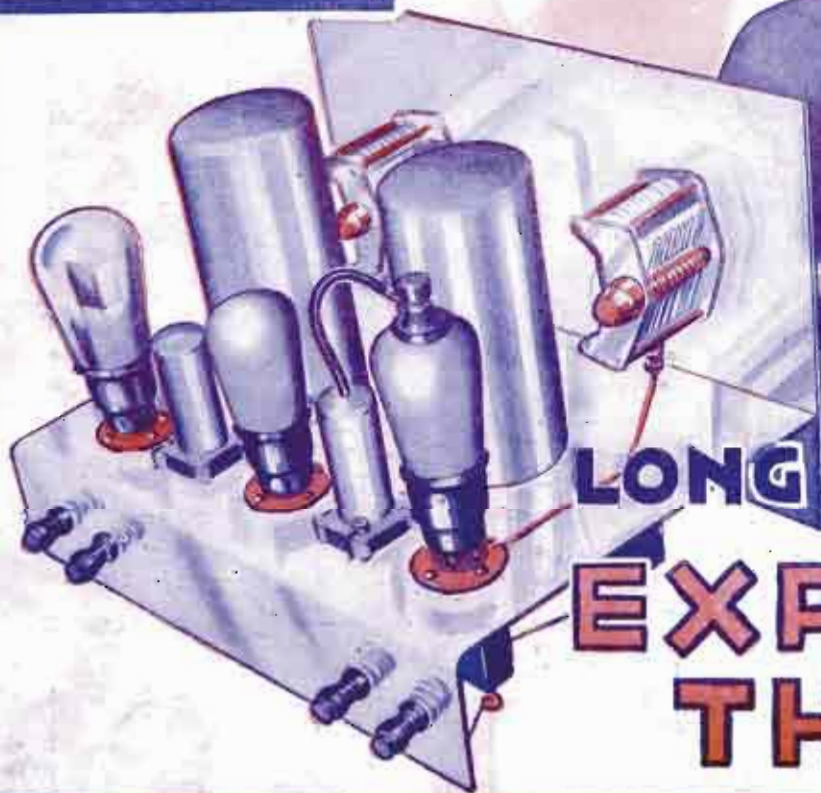
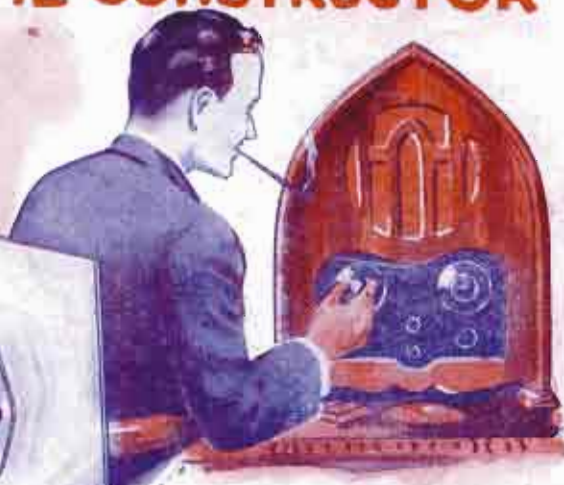

**THE  
LONG-RANGE  
EXPRESS  
THREE**

FOR EVERY SET — *there's a*

**PILOT AUTHOR KIT**

# IN THE HANDS OF RADIO EXPERTS



The leading electric wire manufacturers for over 50 years, Lewcos have been in the van of Radio progress from the commencement. Lewcos Components are indispensable for perfect reception. Send for leaflets and please quote reference numbers :

### COMPONENTS OF EVERY DESCRIPTION.

L.F. and H.F. Transformers	Ref. Nos. W76.
L.F. and H.F. Chokes	" " W76 & 78.
Potentiometers	" " W79 & 81.
Band Pass Filters	" " W73A.
Spaghetti Resistances	" " W78.
Glazite Connecting Wire.	
Silk and Covered Wires.	

# Lewcos

REGD

**LEWCOS RADIO PRODUCTS FOR BETTER RECEPTION**

THE LONDON ELECTRIC WIRE COMPANY AND SMITHS LIMITED, CHURCH ROAD, LEYTON, LONDON, E.10



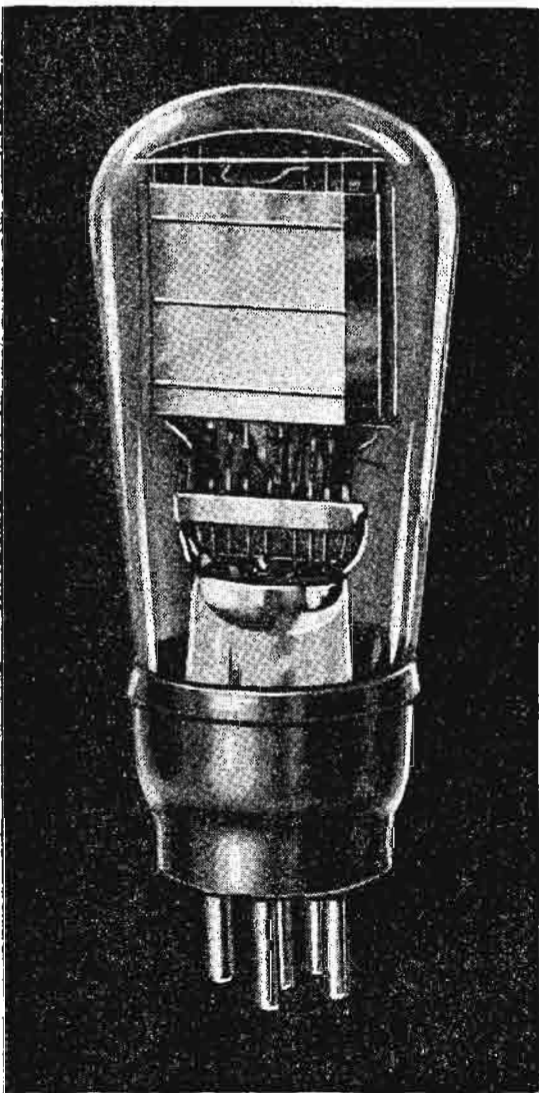

# FACTS YOU SHOULD KNOW ABOUT THE MAZDA 2-VOLT RANGE

In this exceptionally efficient range of 2-volt valves will be found types to suit all battery operated sets.

**THE HL2**, an outstanding example of Mazda sensitivity, is an excellent cumulative grid detector. Amp. Factor: 31. Imped: 20,000 ohms.

**THE S215 VM**, is a new variable-mu screened grid valve of extreme sensitivity and low inter-electrode capacity.

**THE PEN 220 and PEN 220A** are two economical pentodes, which will give ample volume with a very low signal input.

**THE P220 and P220A** will operate balanced armature and moving coil speakers respectively at full volume with extremely economical anode consumptions.

Full details of these and other useful Mazda 2-volt types will be found in the Mazda Catalogue, sent FREE on request.

Mazda Valves are fitted by all leading receiver manufacturers. All good radio dealers stock them.

LOOK FOR "EDDY" IN YOUR DEALER'S WINDOW

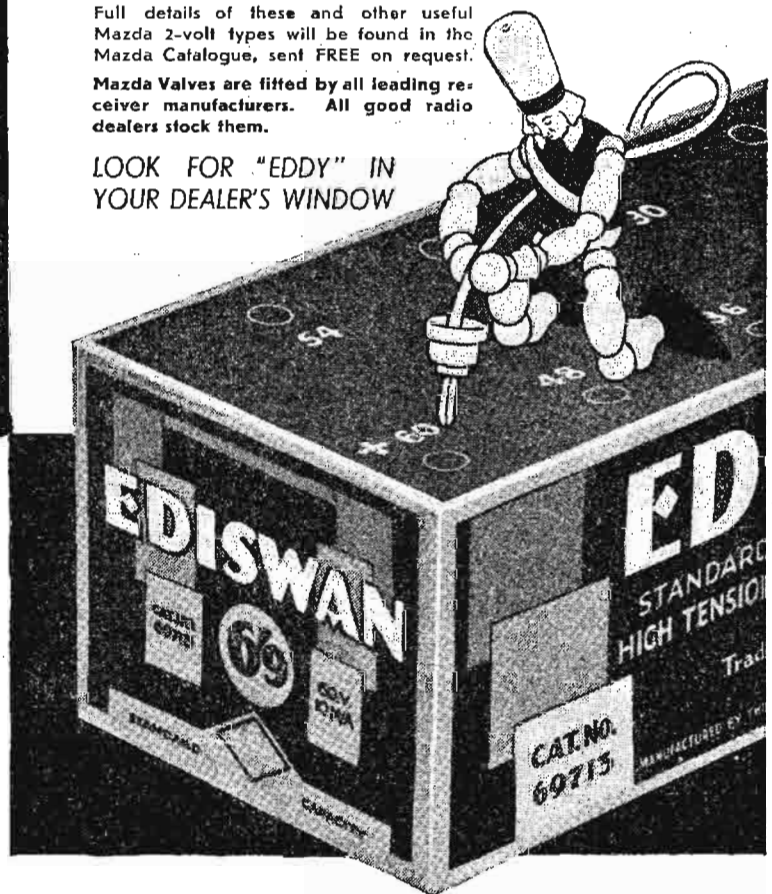

The amazing  
**MAZDA**  
 THE  
 BRITISH  
 VALVES

**100% BRITISH—Designed by British Engineers**

The Edison Swan Electric Co. Ltd.



155 Charing Cross Rd. London. W.C.2

*Mazda Radio Valves are manufactured for The British*

*Thomson-Houston Co. Ltd., London and Rugby.*

V.165

# MAINS RADIO FOR EVERY TYPE OF BATTERY SET

**10/-  
DOWN  
AND BALANCE  
IN EASY  
MONTHLY  
PAYMENTS**

## Cheaper & better than batteries!

"ATLAS" Mains Units bring a new realm of better radio to the battery set owners who are blessed with electric light. Abolishing the distortion of exhausted batteries. Ending the expense of continual replacements. And giving truer, more powerful and more reliable radio for less than one penny a week.

Modernise *your* battery set; make it all-mains operated without alterations to set or valves. Get an "ATLAS" Mains Unit. No other can give the same service, performance and value.

Ask your dealer for a demonstration and post the coupon to-day.

There's a model for every set. D.C. Units from 39/6. A.C., H.T. Units with Westinghouse Metal Rectifier from 52/6, and with Trickle Charger from 77/6. All for 10/- down and fully guaranteed for 12 months.

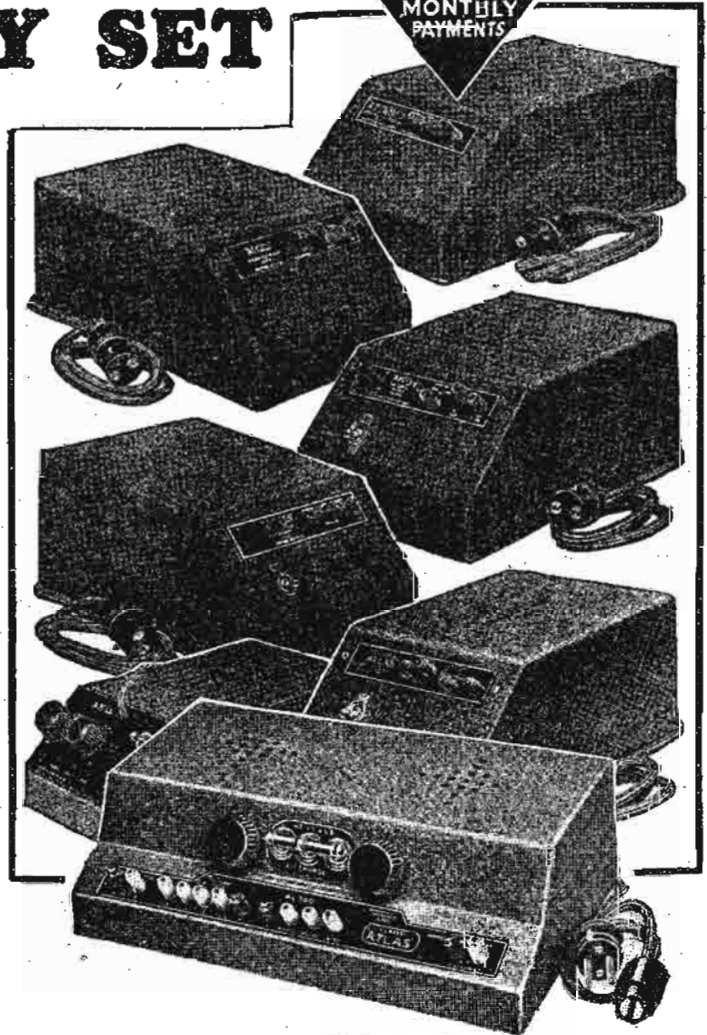

### "ATLAS" COMPONENTS

#### PENTODE OUTPUT CHOKE.

Enables the impedances of pentode and speaker to be matched exactly. No other choke provides six tappings with nine output ratios. Inductance 35 H at 60 m/A D.C. **21/-**

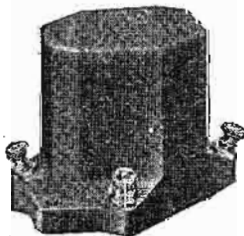

#### L. F. TRANSFORMER.

Ratio 4/1. Primary Inductance 85H. Unprecedented level response and, although designed for parallel feed, retains excellent characteristics with 3 m/A primary current. **5/6**

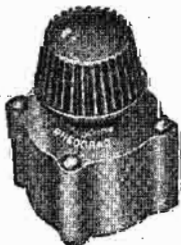

#### RHEOGRAD.

A continuously variable resistance from almost zero to 2 megohms to carry 2 watts. One-hole fixing and "ATLAS" Push-On Knob. For Mains Units, Volume Controls, etc. **5/-**

## "CLARKE'S" "ATLAS" MAINS UNITS

H. CLARKE & CO. (M/cr) Ltd.,  
PATRICROFT, MANCHESTER.

London Offices: BUSH HOUSE, W.C.2.

Scottish Distributors: G. E. S. Co., Ltd., 38, Oswald St., Glasgow.

### POST THIS COUPON NOW!

Messrs. H. Clarke & Co. (M/cr), Ltd., George St., Patricroft, Manchester.  
Please send me copy of Folder No. 68, describing "ATLAS" Mains Units and Components.

Name .....

Address .....

P.R.W. 27-9.



# IMMEDIATE DELIVERY-CASH-C.O.D. or H.P.

**PETO-SCOTT**  
**FIRST IN 1919**  
**-FOREMOST**  
**TO-DAY**

## C.O.D.

All orders over 10/-  
 C.O.D. charges and  
 carriage paid

## EASIWAY

NO DEPOSIT. Strict  
 Privacy. No third  
 party collections. We  
 deal with you direct

## CASH

All orders over 10/-  
 sent carriage paid

### PILOT BAND-PASS UNIT

Whether your set is mains or  
 battery operated, the **PILOT**  
**BAND-PASS UNIT** cuts out  
 programme interference effectively  
 and sharpens tuning to needle-  
 point selectivity. It is simple  
 to attach and can be operated  
 by anyone without technical  
 knowledge. No valves or extras  
 required.

*Instantly converts any  
 Set to Band-Pass  
 Tuning with Needle-  
 sharp Selectivity.*



CASH or C.O.D.

**25/-** Or 6 monthly  
 payments of 4/8

**LISSEN "SKYSCRAPER 3."** Chassis  
 model with (Lissen) S.G., Detector  
 and Pentode valves. Cash Price,  
**£4/9/6.** Balance in 11 monthly payments  
 of 8/3.

Send  
**8/3**  
 only.

**BLUE SPOT SPEAKER UNIT AND  
 CHASSIS.** Type 100U. Cash Price,  
**£1/19/6.**  
 Balance in 7 monthly payments of 5/5.

Send  
**5/5**  
 only

**R.A. VICTOR  
 ATLAS ELIMINATOR.** Type A.C.244.  
 Three tappings.—S.G., Detector and  
 Power. Output: 120 volts at 20 m/a.  
 Cash Price, **£2/19/6.**  
 Balance in 11 monthly payments of 5/6.

Send  
**5/6**  
 only

### 1933 KELSEY SHORT-WAVE ADAPTOR

Tune-in the Short-Wave Stations  
 on your present set. Plug the  
 Kelsey Short-wave Adaptor—  
 it fits without any alteration.  
 No extra valve required; no  
 extra apparatus. Ready for im-  
 mediate use and sold complete  
 with Dial Calibration Chart  
 and simple tuning notes. "How  
 to Hear the Short-Wave  
 Stations," specially compiled by  
 an expert.

*Tunes in the  
 World's Short-  
 Wave Stations on  
 your Existing Set.*



CASH or C.O.D.

**45/-** Or 9 monthly  
 payments of 5/8

## BUILD WITH A PILOT AUTHOR KIT FOR "PRACTICAL WIRELESS" SETS

### LONG RANGE EXPRESS 3

Described in "Practical Wireless"  
 September 24th, 1932.

#### KIT "A"

Complete PILOT AUTHOR  
 KIT of specified parts with  
*Ready-drilled Panel and  
 Chassis*, excluding valves  
 and Cabinet

CASH  
 or C.O.D.

**£5-11-6**

or 12 monthly payments of 10/3.

- 1 Peto-Scott Cabinet in Oak .. 1 5 0
- 1 Celestion Soundex Moving Coil  
 Loud-speaker .. 1 7 6
- 3 COSSOR Valves: (1) 220 V.S.G.,  
 (1) 210 H.F., (1) 230 P.T. .. 2 1 0

**IMPORTANT** Any items sup-  
 plied separately  
 for "Practical Wireless" Sets. If value over  
 10/- sent C.O.D. Carriage Paid. We pay  
 all post charges.

*These are the parts the  
 Author himself used and they  
 fit the FREE BLUEPRINT.*

- 2 POLAR No. 2 .0005 mfd. Variable Condensers .. 2 0 0
- 1 pr. TANNAY Coils Shielded .. 15 0
- 1 WEARITE Standard Screened H.F. Choke .. 3 6
- 1 WEARITE Special Screened H.F. Choke .. 4 0
- 2 T.C.C. .0001 mfd. Type S. Fixed Condensers .. 2 0
- 1 T.C.C. .0001 mfd. Upright 34 clip type fixed  
 condenser .. 1 6
- 1 T.C.C. .01 mfd. type B Fixed Condenser .. 2 6
- 3 LISSEN 2 mfd. Mansbridge type Condensers .. 7 6
- 2 LISSEN 2 mfd. Mansbridge type Condensers .. 7 0
- 1 DUBILIER 30,000 ohms 1 watt fixed resistance .. 1 0
- 1 DUBILIER 10,000 ohms 1 watt fixed resistance .. 1 0
- 1 LISSEN 2 megohms grid leak .. 1 3
- 2 CLIX 4-pin chassis mounting valve holders .. 1 4
- 1 CLIX 5-pin chassis mounting valve holder .. 0 9
- 1 VARLEY Stone H No. D.P. 2, I.F. Transformer .. 11 6
- 1 WEARITE 10 Henry 35 m.a. I.F. Choke H.T. 10 .. 10 0
- 2 WEARITE Ganged Wave-chance switch .. 5 0
- 1 LISSEN Precision .0043 mfd. Reaction Condenser .. 2 6
- 1 LISSEN 3 point "On and off" switch .. 1 0
- 1 LEWCOS 30,000 ohms Potentiometer .. 3 0
- 4 BULGIN Panel Pointers .. 0 8
- 4 CLIX Spade Terminals (Aerial, Earth, L.T. +,  
 L.T. -) .. 0 8
- 6 CLIX Wander Plugs (G.B. -2, G.E. -1, H.T. +,  
 H.T. -1, H.T. +2, G.B. +) .. 0 9
- 1 Loop Range Express Three 16 gauge metal panel  
 12" x 8" ready drilled .. 4 0
- 1 BULGIN 7-way Battery Cord .. 2 6
- 1 PAROUSSI Aluminium Chassis 12" x 9" (ready  
 drilled) .. 5 6
- 2 Coils Glazite, Screws, Hex, etc. .. 2 0

KIT "A" CASH or C.O.D. .. 55 11 6

## IMMEDIATE DELIVERY-KITS OR PARTS

### DOLPHIN STRAIGHT THREE

Described in "Practical Wireless"  
 September 24th, 1932.

#### KIT "A"

Complete PILOT AUTHOR  
 KIT of Specified Parts with  
*Ready-drilled Panel*; ex-  
 cluding valves and cabinet

CASH  
 or C.O.D.

**£3-7-6**

Or 12 monthly payments of 6/2.

- 3 Mullard Valves: P.M. 2 D.X., P.M.  
 1 L.F., P.M. 2 .. 1 2 9
- 1 Clarion "Dolphin Three" Cabinet,  
 without chassis .. 0 10 9
- 1 "MOTOR" S.40 Super Power Unit  
 with Cone Chassis .. 1 19 0

**IMPORTANT** Part Kits, miscel-  
 laneous components  
 or accessories are available under our own  
 Easy Way H.P. System. Send us list of  
 your wants. We will quote by return with-  
 out any obligation.

*These are the parts the  
 Author himself used.*

- 1 JACKSON BROS. .0005 mfd. Variable Condenser,  
 mid-log line with slow-motion dial .. 14 0
- 1 READY RADIO Dual Range coil unit .. 10 6
- 1 IGRANIC .00015 mfd. reaction condenser .. 3 0
- 1 BULGIN Transcoupler .. 11 6
- 1 SLEKTUN Coil 5-1 L.F. transformer .. 4 9
- 3 W.B. 4-pin valve holders .. 1 6
- 1 T.C.C. .0002 mfd. fixed condenser, three-terminal  
 type .. 2 4
- 1 LISSEN 2 meg. grid leak .. 1 3
- 3 BELLING LEE Terminal Mounts .. 2 0
- 6 BELLING LEE Terminals (Aerial, Earth, Loud-  
 speaker +, Loudspeaker -, and Two Pick-up) .. 1 3
- 1 BELLING LEE 6-way Battery Cord .. 2 0
- 4 CLIX Wander Plugs, G.B. -1, G.B. -2,  
 G.B. + .. 0 6
- 1 Ebonite Panel, 12" x 7", ready drilled .. 3 0
- 1 Wooden Baseboard 12" x 8" .. 1 0
- 2 BULGIN Panel mounting dial pointers .. 0 4
- 1 CLARION Chassis .. 7 6
- 1 Coil Glazite, screws, etc. .. 1 0

KIT "A" CASH or C.O.D. .. 33 7 6

Any items supplied separately for  
 "Practical Wireless" Sets. If value  
 over 10/- sent C.O.D. Carriage Paid.  
 We pay all post charges.

## PETO-SCOTT CO. LTD. 77, CITY ROAD, LONDON, E.C.1

Dear Sirs,—Please send me C.O.D./CASH/H.P. ....

for which I enclose £ s. d. CASH/H.P. Deposit Send me your FREE 1933 Catalogue.

NAME .....

ADDRESS .....

PR.W. 24/9/32 .....

*Buy by Post—its Quicker*



# It's So Simple.

to improve your present set or modernise an old one, with our practical and pictorial descriptions devised to be easily understood by ALL. The alterations or additions can be made with ease. First note the components you will need, but, be sure you obtain nothing but the genuine Bulgin Quality Components—then, note carefully the connections and carry them out to the letter—that's all. You will be agreeably astonished at the results.

**SPECIFY BULGIN QUALITY COMPONENTS** and your entire satisfaction is assured

**FOR FURTHER HELP IN SET CONSTRUCTION SEND FOR OUR NEW 80-PAGE CATALOGUE AND MANUAL**

Send 2d. postage.



## PUT A 'TRANSCOUPLER' HERE

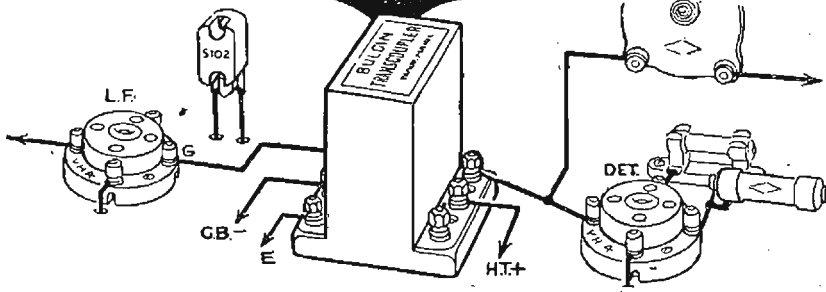

Brilliant reproduction is assured by incorporating this new unit in place of existing L.F. Transformer. This diagram illustrates the simple connections, and, once incorporated you will be astounded at the evenness of amplification and enormous improvement in bass and treble response. Universal type for use in all receivers. Fitted in a few minutes by even inexperienced amateur constructors. One of the greatest successes at Radiolympia.

**STOP PRESS.**  
**THE BULGIN 'TRANSCOUPLER' SPECIFIED AGAIN.**  
 See page 13 in this issue. **11/6**

## GREATER VOLUME & PURITY

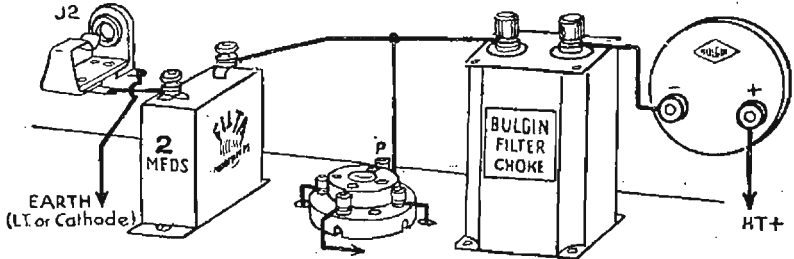

For greater volume and purity fit a Bulgin Filter Choke between H.T. plus and the anode of the valve. Then feed the loudspeaker through a 2 mfd. condenser connected to the anode of the valve. The other side of the loudspeaker should return to L.T.—or the cathode if the valve is indirectly heated. A Bulgin Milliammeter is shown on the right of diagram, and where incorporated serves as a valuable guide, not only on current consumption, but also as a visual indicator of overloading or distortion. If meter kicks to the left, valve is under biased; if to the right, over biased. Keep the pointer steady by correcting bias.

**BULGIN FILTER CHOKES**  
 Standard type, 20 H. **7/6**  
 at 20 m/a  
 Power type, 20 H. **10/6**  
 at 50 m/a  
**MILLIAMMETERS**  
 All ratings  
 Prices from **8/6**

## UP-TO-DATE SIMPLIFIED MASTER CONTROL

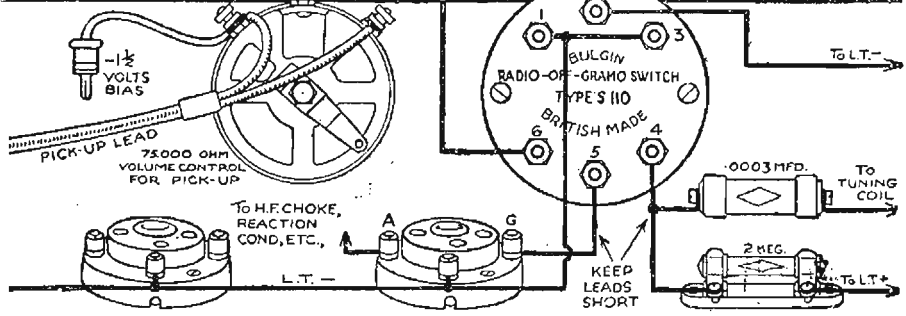

Bulgin S.110 Switch is a D.P.D.T. type with central "OFF" position. It gives complete control over the Radio/gramo and On/Off switching of a battery set. The diagram clearly shows the connections. The normal connections for a Volume Control for use with a pick-up are also shown. The correct position for the Switch is close to the valve to be controlled. If valveholder is well away from panel, use extension control shaft E.H.4 with supporting bracket E.H.6, this allows the leads to terminals 4 and 5 to be kept short—a most important point.

**BULGIN S.110 SWITCH**  
 Rotary D.P.D.T., "OFF" position; with engraved indicating plate. **2/6**

Free Book "ALL ABOUT TUNING AND TUNING COILS" NEXT WEEK!



# Practical Wireless

Vol. 1. No. 1. | Editor: F. J. CAMM | Sept. 24th, 1932.

Technical Staff:  
H. J. Barton Chapple, Wh.Sch., B.Sc. (Hons.), A.C.G.I.,  
Frank Preston, F.R.A., W. J. Delaney, W. B. Richardson.

## ROUND THE WORLD OF WIRELESS

### Introducing Ourselves

**P**RACTICAL WIRELESS makes its debut in the confident belief that it will receive a hearty welcome from the large and ever-growing circle of wireless enthusiasts, more particularly those interested in home construction and the experimental side of wireless. Although in the brief space of a very few years the knowledge of this fascinating new world of the ether has grown to large proportions, we are still little more than on the threshold of the intriguing possibilities the future holds forth. Rapid as the advances have been, the near future will bring forth new discoveries, new ideas, and new technique just as certain as day follows night, and every wireless enthusiast, if he is to derive full pleasure and interest from his hobby, will require as an absolute necessity that his knowledge be kept right up to date.

### Keeping Up to Date

**I**T will be part of the policy of PRACTICAL WIRELESS to keep its readers abreast of everything new. Writers, acknowledged as authorities in various branches of wireless and in touch with every new development, will contribute on every subject that has a practical value to the reader. Skilled designers, with many successful sets standing to their credit, will exercise their ingenuity in the design of new sets combining for the constructor and experimenter the essentials of novelty with efficiency, bearing in mind also the important question of cost. Everything that is new, when tested and proved in its practical worth, will find its way into the pages of PRACTICAL WIRELESS.

### Simplicity of Treatment

**A**ND, of great importance, particular care will be taken in presenting the contents in clear and simple language. Highly technical terms will be dispensed with wherever simple description can be employed, and diagrams will be prepared and explained so as to be readily understood. Thus the reader with a modest technical knowledge, or even the keen amateur, will find PRACTICAL WIRELESS appeals to him as well as to the reader with a sound technical knowledge.

New sets appearing at frequent intervals will be an attractive feature of PRACTICAL WIRELESS. Every set described will first

be thoroughly tested under varying and stringent conditions so that the reader may know that it will do all that is claimed for it. It is the intention also to cover every need of the home constructor in the sets featured. It will be explained how a set may be modified to suit particular conditions; how it may be adapted for use as a radio-gram or as a short-wave receiver; how flat dwellers with restricted space can adapt a set to meet these conditions. PRACTICAL WIRELESS plans to deal with each set adequately rather than to produce too many new designs, a policy which is apt to leave readers with difficulties to surmount after a set is made.

### Our Laboratory

**A** WELL-EQUIPPED laboratory staffed by enthusiastic experts closely associated with the home constructor movement, will examine and test the latest

*A Fine Souvenir  
for Regular Readers—*

**VALUABLE  
CONSTRUCTOR'S  
ENCYCLOPÆDIA !**

See Pages 56 and 57 for full particulars

components, the results of which will be reviewed in PRACTICAL WIRELESS. This feature will be of invaluable help to the home constructor in planning and making up sets. Every component used in PRACTICAL WIRELESS sets will pass our laboratory tests, and our Advice Bureau will help readers with their difficulties and problems. Expert advice is available and readers are invited to use it freely. In view of the constant and marked progress that is being made in the design and construction of components, this service will be of the greatest value to those planning and making sets.

### Readers' Ideas Invited

New ideas from readers are invited. If you have a clever notion or an ingenious

gadget you have discovered for yourself, it will be printed if approved and paid for at our usual rates. We shall also welcome suggestions and criticisms. They will assist us in carrying out our policy of fully satisfying the reader in the service we give him.

### Our Presentation Volume

**O**NE word more. To signalize the appearance of our first number we are offering to all who become regular readers a most attractive Presentation Volume which will be of the greatest help to wireless constructors. Read about this wonderful offer for yourself. Particulars are printed on pages 56 and 57. It is an opportunity that should not be missed.

### Radio Luxembourg

**T**HE new 200-kilowatt Radio Luxembourg transmitter has started its preliminary tests on 1,275 metres, despite international protests regarding the choice of wavelength. A young German woman, who is a fluent speaker of five languages, has been specially engaged as studio announcer. The *Compagnie Luxembourgeoise de Radiodiffusion*, who are owners and operators of this super-power station, will devote the Sunday programme hours entirely to broadcasts sponsored by British commercial firms. Publicity transmissions are also to be carried out on weekdays for French and German concerns. As no tax is payable by listeners in the Grand Duchy of Luxembourg the expenses of running the service will be entirely defrayed by revenues secured from advertisements.

### Budapest May Change

**T**HERE is a possibility that the 550-metre channel now used by Budapest may be abandoned in favour of a wavelength of 210 metres when the high-power station to be erected at Lakihegy (Hungary) is brought into being. Work has already been started on the plant which it is hoped may be completed before the end of the year.

### Another French Transmitter

**T**HE French Posts and Telegraphs department propose to erect a 120 kilowatt station at Tramoyes, in the immediate neighbourhood of Lyons. This will be the third high-power transmitter to be constructed under the General Ferrié scheme for the reorganization of the French broadcasting system.



# Round the World of Wireless (continued)

## Forty-four More Russian Stations!

ACCORDING to reports from Moscow the Soviet Union intends to build during 1933 forty-four more broadcasting stations, totalling an output of 380 kilowatts. Russia already operates fifty-seven wireless transmitters. The new super-power stations at Sverdlovsk, Minsk, and Kiev, which have been planned on similar lines to that of Moscow (Trades' Unions) will be ready to take over the radiation of daily programmes by the end of this year.

## What a Medley!

ALTHOUGH no definite date has been fixed, listeners to the Danish programmes via Kalundborg may hope to hear during the autumn and winter months a series of concerts in which Eskimo musicians and singers will take part. The relay will be carried out from the Julianahaab wireless telegraphy station in Greenland.

## Ladies Only!

CONTRARY to the principle adopted by other Continental countries, with the exception of one male official at Milan, the Italian broadcasting studios only employ women announcers. With the opening of Bari, they now number a round dozen.

## Lucky German Scholars!

IN Germany the normal listening tax of 2 marks (roughly 2s. 6d.) has been reduced to 9d. per month in the case of schools utilizing their receivers solely for the reception of educational broadcasts.

## Where the Mormons Are!

WITH the completion of its 50-kilowatt transmitter, KSL, Salt Lake City, (Utah), U.S.A., will be one of the highest powered stations in North America. It will start operations by the end of September, when it joins the Columbia Broadcasting system by linking up with WABC, New York. The wavelength is 265.5 m. (1,130 kc/s.). Other U.S.A. stations to work shortly on increased power are: WHAS, Louisville (Kentucky), 366 m.; WCCO, Minneapolis, 370.4 m.; and WCAU, Philadelphia, on 256 m.

## High-Power Transmitter for Alexandria.

THE Egyptian Government has placed a contract with an Italian concern for the supply of a high-power transmitter to be built at Alexandria, and to be similar in type to the one recently erected at Coltano. It is to be used for both telegraphy and telephony, and may eventually take over a radio programme service. Egypt possesses four small privately owned broadcasting stations, namely: Radio Heliopolis (270 m.); Radio Szabo (504 m.); Amir Farouk (321 m.); and Port Said

## INTERESTING AND TOPICAL PARAGRAPHS

### A New Idea in Radiogram Cabinets

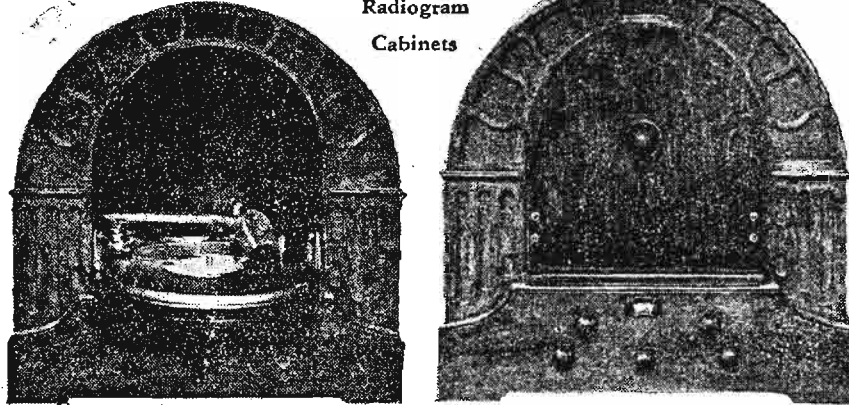

A cleverly designed Radio-Gram cabinet is shown above, in the open and closed positions. The cabinet is of the ordinary small table type, and the top portion houses a turntable and pick-up. This lets down after the manner of a flap, permitting the gramophone to be used. The receiver is mains operated and fitted with a Magnavox moving coil loud-speaker.

(285 m.), the latter being operated by an Anglo-French association, the Radio Club of the Isthmus of Suez.

### Do You Listen to Buenos Aires?

UNDER favourable conditions broadcast programmes from three of the principal studios in Buenos Aires (Argentine Republic) can now be picked up between 1.30 and 3.0 a.m. British listeners report reception of LR4, Radio Splendid (303 m.); LR3, Radio Nacional (316 m.); and LR2, Radio Prieto (330 m.). Transmissions from Buenos Aires are also relayed at regular intervals to the United States and re-transmitted through WABC, New York, and the Columbia network.

### Spain's Status Quo.

ALTHOUGH on four different occasions schemes have been put forward for a complete reorganization of the Spanish broadcasting system, it is hardly likely that any of the proposals put forward will mature in the immediate future. Dissension amongst the radio authorities in Spain

has arisen owing to the fact that the plan suggested called for centralization and full control of the network by Madrid. Barcelona and the province of Catalonia insist upon complete independence and freedom of action. As at present conceived, Madrid would eventually possess a 120-kilowatt station, allotting to Barcelona and other provincial cities transmitters of lower power.

### Poor Pentodes!

THERE is a growing tendency to use pentode valves for doing any sort of job except the one for which they were designed; there is, however, considerable scope in the new season's battery pentodes for using them as combined detector output.

### Don't Try This!

IN some ways I admire the man who admitted to a valve manufacturer that he had tried unsuccessfully to mend one of their valves. He mentioned that he had little difficulty in soldering the filament, but he broke the grid. When asked (with a suppressed smile) how he intended to replace the bulb, he said that he would not have worried about that, as he would have protected the electrodes with a wooden box!

### The Berlin Show.

I WAS not very impressed by the Berlin Radio Show, except by its size; one hall alone had over five hundred stands in it. There was one item of particular interest, however, which took the form of a kind of valve with innumerable grids; the idea is that the two anodes are connected across the output of an eliminator when the grids provide the various voltage tapplings. The great advantage of this is that the voltages of the tapplings do not vary with the current drawn as is the case with the conventional arrangement.

### A "Show" Note.

AT the Show I noticed no less than ten kits, 211 different three-valve mains sets, only two four-valve battery sets and, incidentally, only one five-valve "straight" portable.

### A New Spanish Custom.

I OFTEN hear people grouching about their electric light mains for one reason or another, but they do not know when they are well off. I am designing a gadget for a harassed friend who is in Spain and has an A.C. supply, but when it fails (which is often) the company switches over to D.C. and bang goes the mains transformer in the unfortunate radio set.

### The Variable Mu.

THE variable-mu valve has come to stay, and listeners who are troubled with swamping from a powerful local should fit one if it is humanly possible.—JACE.

## SOLVE THIS!

No. 1.

### A WEEKLY WIRELESS PROBLEM.

THREE books will be awarded each week for the first three correct solutions opened. Mark envelopes Problem No. 1, and send to The Editor, PRACTICAL WIRELESS, Geo. Newnes, Ltd., 8-11, Southampton Street, Strand, London, W.C.2. To reach us not later than Sept. 26th.

Brown owns a wireless set, and being troubled by chronic motor-boating decided to introduce a decoupling device. He accordingly fitted a Spaghetti resistance and condenser—the actual values he chose being 100,000 Ohms and 2 mfd. The detector valve was the one he chose for decoupling, and this was coupled to the next valve by an R.C.C. unit. When the alteration was complete signals were very much reduced—in fact, almost inaudible. Wiring was O.K.—what do you think was the reason?

# CONTROLLING VOLUME

W. J. Delaney discusses the Various Methods, and deals with the important question of Overloading the Valves

This photograph shows Mr. W. J. Delaney.

IS your output valve overloaded? When you tune in to a loud station, or when a loud passage of music or a very low note is received, does your reproduction sound coarse, or is it accompanied by a "rattle"? Unless your loud-speaker gives forth the same tone on either soft or loud signals, then overloading is taking place in the receiver. There are two remedies

schematically as well as in conventional form (for purposes of comparison) a variable resistance

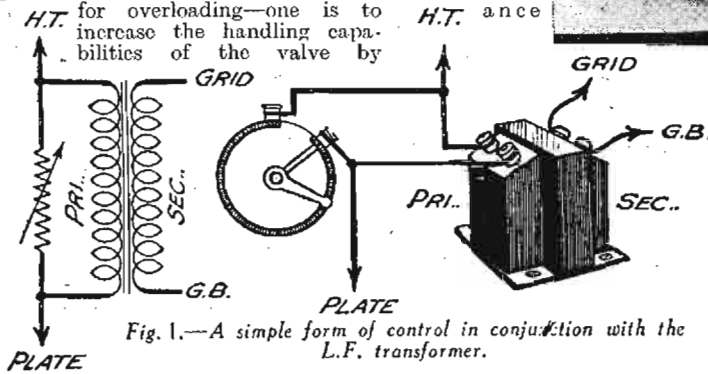
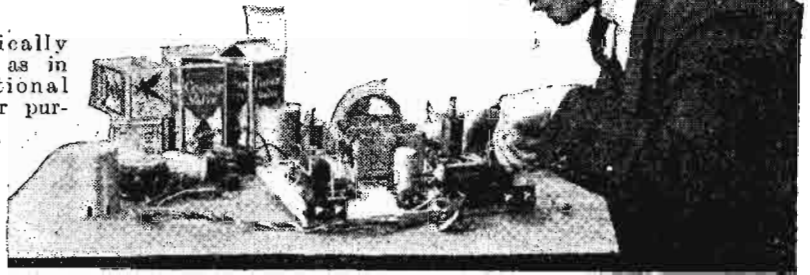

Fig. 1.—A simple form of control in conjunction with the L.F. transformer.

applying more H.T., and the other is to cut down the signal strength.

A number of receivers have the reaction control labelled "Volume Control," but this is not strictly correct. A volume control should be able to cut down the strength of any signal, but the reaction control can only build up the strength of received signals, and cannot cut down below the original strength received by the detector. There are several different forms of volume control, but there are very few which do not possess some fault. However, it should be a simple matter to decide upon which type of control will suit your particular receiver, and the following notes describe the more common forms of control and their advantages or disadvantages.

### The Transformer.

In conjunction with the ordinary type of low frequency transformer there are two possible arrangements. These are shown in Figs. 1 and 2. In Fig. 1 is shown

component the presence of an external resistance across either primary or secondary will materially affect the response curve and the reproduction will be affected. In some cases, particularly in the cheap transformer line, the reproduction may be improved owing to the flattening of the curve. The value of the resistance in Fig. 1 should be about 100,000 ohms—not more. In Fig. 2 a high resistance potentiometer is connected across the secondary winding—the arm of the potentiometer being joined to the grid

shunted across the primary of the transformer, and the value of the resistance should be chosen so that when "all-in" it does not have too great an effect upon the reproduction quality. Of course, when the transformer is a high-class

shunted across the primary, and therefore this method will affect the quality more than the Fig. 2 arrangement. The potentiometer should have a value of 1 or 2 megohms. To ensure noiseless adjustment a fairly good-class component should be employed.

Where resistance capacity coupling is employed, the grid leak can conveniently be substituted by the potentiometer method of Fig. 2, and this arrangement is shown in Fig. 3. Very little, if any, distortion is introduced by this method of volume control, and the only trouble that can arise here is noisiness due to a poor contact between the resistance element and the moving arm. This is the best method of L.F. volume control.

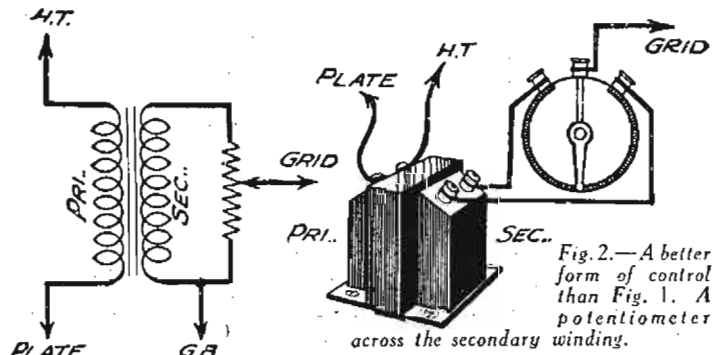

Fig. 2.—A better form of control than Fig. 1. A potentiometer across the secondary winding.

two possible arrangements. These are shown in Figs. 1 and 2. In Fig. 1 is shown

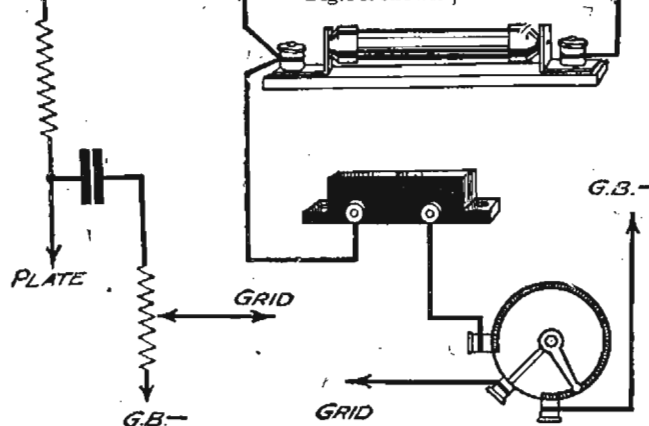

Fig. 3.—A potentiometer used instead of the grid leak in an R.C. amplifier.

secondary winding—the arm of the potentiometer being joined to the grid of the following valve. In this case the value of the resistance across the transformer is constant the whole time, and the adjustment of the arm simply taps off the required signal voltage. In Fig. 1 the adjustment of signal strength also varies the value of the resistance

### Overloading the Valves.

It is not always in the L.F. side of the receiver that overloading troubles arise. In sets fitted with one or more H.F. stages the detector valve may be overloaded, and it is, therefore, necessary to introduce some form of control in the aerial circuit. A very common form of control is a series aerial condenser—Fig. 4—but this will affect the tuning adjustment, and when two or more dials have to be adjusted for tuning, this alteration of the aerial tuning condenser may make it difficult to get an accurate setting. It is not, therefore, ideal, but will be found good enough for simple sets, and can, in fact, be used with a simple

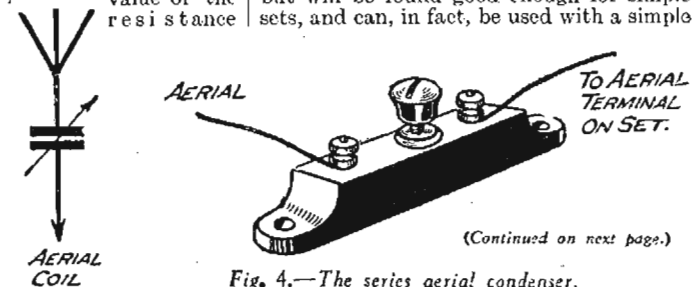

Fig. 4.—The series aerial condenser.

(Continued on next page.)

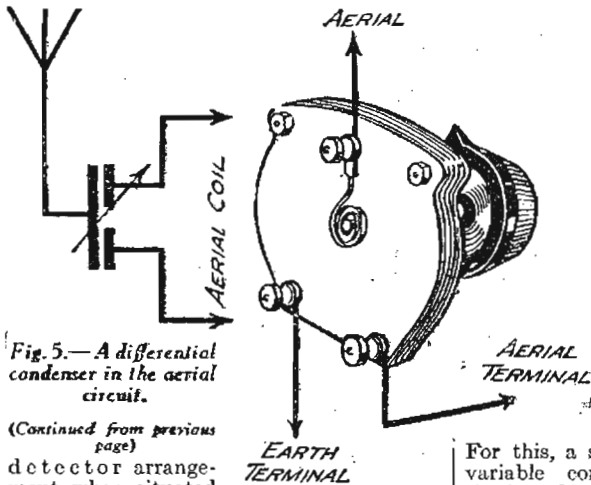

Fig. 5.—A differential condenser in the aerial circuit.

(Continued from previous page)

detector arrangement when situated very close to a powerful main station. The value should be .0003 maximum, and whilst the air-dielectric condenser is the best from the "loss" point of view the simple semi-variable (Formodensator) is quite O.K. A much better aerial arrangement is shown in Fig. 5—this arrangement not affecting the selectivity as does Fig. 4. A simple differential reaction condenser of .0003 mfd. is used for this, although better control is sometimes afforded by an air-dielectric condenser. The moving

For this, a small semi-variable condenser of .0003 mfd. is joined between the earth terminal and one set of fixed plates. The semi-variable is adjusted until a value is reached where the setting of the moving plates of the differential does not have any effect on the tuning. This is a very good arrangement.

Another Form of Aerial Control

Fig. 7 shows another form of aerial control, using this time a variable resistance. The value should be 25,000 or 50,000 ohms, and should be of the potentiometer type, having three terminals. One end of the resist-

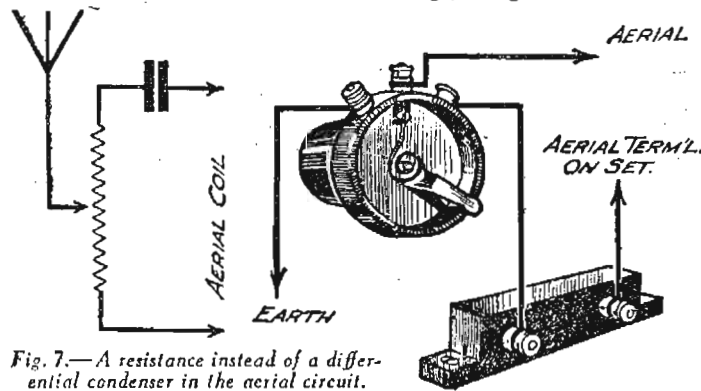

Fig. 7.—A resistance instead of a differential condenser in the aerial circuit.

plates are joined to the aerial lead, and one set of fixed plates is joined to earth and the other end to the aerial terminal of the set. This gives a very smooth control of volume and does not materially alter the tuning of the set. A more elaborate version, for use in band pass circuits and other critical tuned circuits, is shown in Fig. 6.

ance element is joined to earth and the other end is joined to the aerial terminal via a small fixed condenser, value about .001 mfd. The arm is joined to the aerial. This gives a

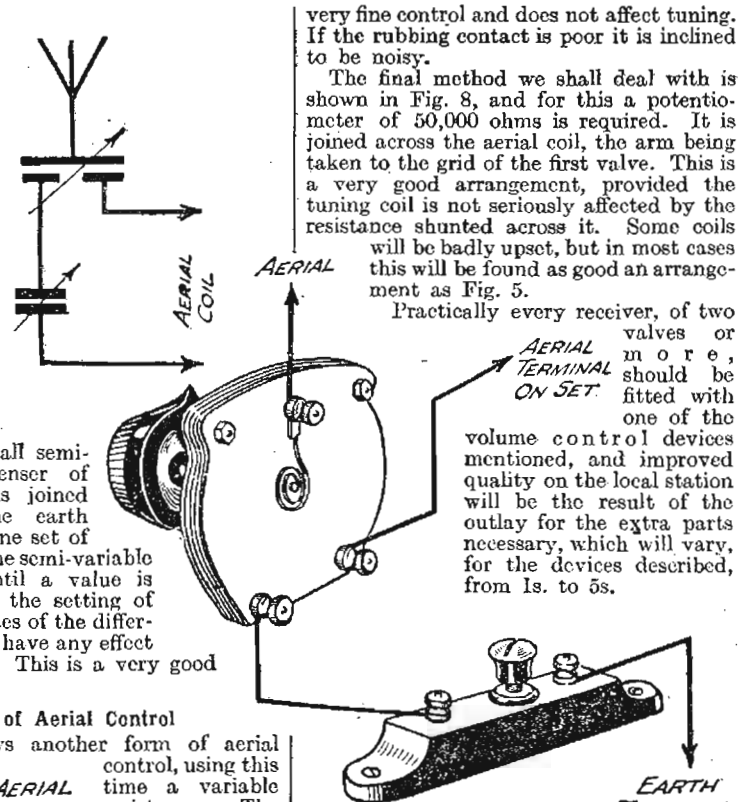

Fig. 6.—An improved form of the arrangement shown by Fig. 5.

MAKE CERTAIN OF YOUR COPY OF OUR SOUVENIR ENCYCLOPEDIA SEE PAGES 56 AND 57 FOR FULL DETAILS

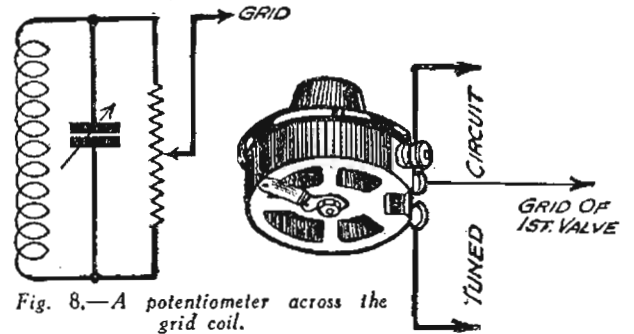

Fig. 8.—A potentiometer across the grid coil.

very fine control and does not affect tuning. If the rubbing contact is poor it is inclined to be noisy.

The final method we shall deal with is shown in Fig. 8, and for this a potentiometer of 50,000 ohms is required. It is joined across the aerial coil, the arm being taken to the grid of the first valve. This is a very good arrangement, provided the tuning coil is not seriously affected by the resistance shunted across it. Some coils will be badly upset, but in most cases this will be found as good an arrangement as Fig. 5.

Practically every receiver, of two valves or more, should be fitted with one of the volume control devices mentioned, and improved quality on the local station will be the result of the outlay for the extra parts necessary, which will vary, for the devices described, from 1s. to 5s.

Camouflaging the Loud-Speaker

NO doubt many listeners have felt on occasions that the loud-speaker could be less obtrusive, and some manufacturers have also felt the same thing as is evidenced by more than one design. On the Continent some quite ingenious ideas have been developed to dispense with the orthodox form of loud-speaker in order not to mar the appearance of a room furnished in the ultra modern Continental style. To assist readers who would like to experiment in this direction we may mention the following ideas:—

The sounding board of a Piano (that is the portion below the keyboard) will be found roomy enough at one end to accommodate a fair sized speaker. Provided this does not deal with too much power, the slight vibration of the piano strings which is set up will add tone to the repro-

duction. Naturally, if too much volume is used, the reproduction will suffer.

Some forms of easy chair or settee will have room at either the back or under the seat to take a moderate size of cabinet-speaker. Of course, if kapok, hair or similar filling is used this idea is impracticable. Some of the box-spring types of furniture will, however, permit of this idea being carried out.

No doubt other ideas will present themselves to readers, and it will often be found that the illusion of reality is greatly improved owing to the non-appearance of the wireless apparatus.

ODDS AND ENDS

Programme Mixing

HOW often have you listened to a radio play and wished that a background of soft music was available? Or has not the occasion often arisen when you have played on your gramophone some dramatic speech or recitation, and would have preferred a light musical accompaniment. These effects are possible if you possess a radio gramophone, and the only outlay necessary is for a component known as a fader. This is a Potentiometer with a centre tap, and when connected in the circuit it is possible to arrange that radio signals are faded out to nothing and gramophone music is brought up to full volume by the mere rotation of one control, or by suitably rearranging the connections, the two reproductions may be mixed to provide the effects mentioned in the opening sentences.



# AN EXPERIMENTER'S

# BASE-BOARD

Here is a baseboard which will enable you quickly to test out any particular circuit—no drilling is required

By W. H. DELLER

THE wireless history of many fans can be traced by the collection of baseboards and panels, hived up in some odd out-of-the-way corner, that had once formed the necessary anchorage for the component parts comprising the very latest thing in radio circuits. As the fashion changed so were numerous wood screws removed to release the parts from their respective positions and certain pieces of apparatus re-used in the building of another set. The new layout would not often accommodate itself on the old board, and the panel was a certain absentee from the new scheme of things. These considerations have delayed the reconstruction of many a set until conditions of reception became so bad that something simply had to be done. The rapid progress in design led the writer to devise a simple and rapid means of securing components in their relative positions for "wiring-up," and when re-arrangement

Fig. 3.—Details of the fixing bolts.

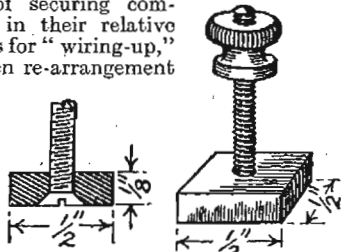

became desirable the change-over could be made with the utmost ease.

### The New Method

Having fulfilled these requirements, a description and instructions for making it should prove of interest to those who are keen on trying out new circuits, and more especially concerns the advanced experimenter. Briefly, the method employed consists of a T-slotted board carrying a terminal strip and panel mounting strip

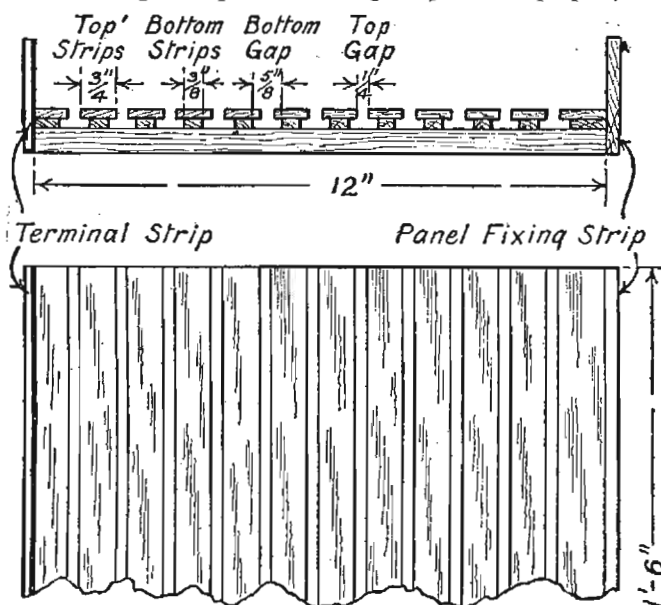
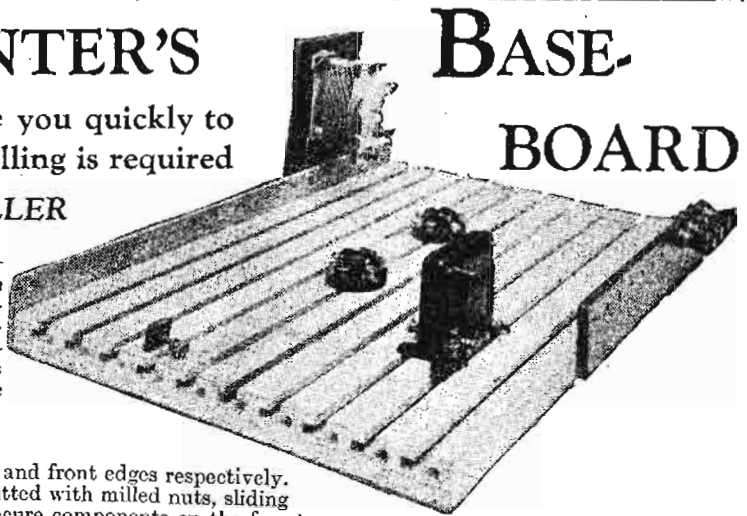

Fig. 2.—Part plan and section of the baseboard.

Fig. 4.—Photograph of the completed baseboard, showing methods of using the clamps.



along the rear and front edges respectively. Special bolts fitted with milled nuts, sliding in the slots, secure components on the face of the board, and additional fixing is provided by means of small finger clamps. Regular panel-mounting components, such as variable condensers, may be fixed by the usual means to small individual panels which are provided with holes along the bottom edge to pitch with the holes drilled in the panel-mounting strip and fixed thereto with screws and nuts. Thus, a .0005 mfd. variable condenser so mounted could immediately be used in the formation of any circuit calling for such a condenser. Regular panels may also be attached to the strip in similar fashion. It is, therefore, apparent that all classes of components are readily mountable by the adoption of this method.

### Constructional Details

The base described is 18in. in length by 12in. in width, and one made up to these sizes should provide sufficient area for normal requirements. Should a larger board be required, it can be made any suitable length, and the width can be increased or decreased by multiples of the distance of the slot centres. A piece of 1/2in. plywood, cut and planed on all edges to 18in. x 12in., forms the foundation of the board. The following strips of 3/4in. hardwood (American whitewood is admirably suited for the purpose) are also required: 11 pieces

3/4in. wide; 1 piece 1in. wide; 10 pieces 1/2in. wide; 1 piece 1/4in. wide; and 1 piece 3/8in. wide. All these pieces are cut square on the ends to a length of 18in. It would be as well to point out that these strips must be of uniform thickness and must also be parallel in their width. This is most important, as any irregularity in thickness will have a direct bearing on the flatness of the working surface of the finished board. For this reason it is desirable to have the strips machine-sawn from a prepared board 1/8in. thick.

### Fixing the Strips

The next step is to fasten the ten strips

3/4in. wide to the underside of ten of the 1/2in. strips with a little liquid glue uniformly spread between, taking care that they are centrally placed, as shown in Fig. 1, and held in place with three fine panel pins, 1/2in. long, driven in with the points flush with the under face of the 3/4in. strip. The remaining 1/2in. strip is fixed to the 1/4in. strip in like manner, excepting that they are placed with their edges flush. The 1in. strip is also attached to the 3/8in. strip in the same manner. These completed pieces are now fixed to the plywood. Commencing with the 1/2in. and 3/8in. strips joined together, glue along bottom edge and place on to plywood with the plain edge flush with the 18in. edge of the board, driving the three pins home. The ten 1/2in. and 3/4in. strips are now fixed likewise, the 1/2in. portions being exactly 1/2in. apart. The best means of ensuring this happening is to use a gauge consisting of a piece of material of the correct width between each strip as it is secured in position. The remaining piece is also attached; reference to Fig. 2 should make the foregoing remarks clear.

The panel-fixing strip is a piece of 1/2in. hardwood, 2 1/2in. wide and the same length as the board. This is drilled with 3/8in. dia. holes 1in. down from the top edge, equally spaced 1in. apart. This is fixed with wood screws in the position shown.

### Fixing Bolts

Reference to Fig. 3 shows that the fixing bolts consist of countersunk-head screws with additional heads in the form of 1/2in. squares of 1/2in. ebonite, the object of these pieces being to prevent the bolts from turning in the slots whilst nuts are being tightened. The difference between the head and width of slot allows the bolt a side movement of 1/2in. Drill and countersink

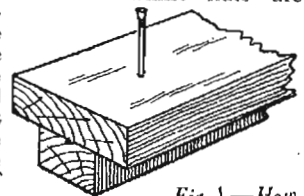

Fig. 1.—How to assemble the T-pieces.

a tapping hole, to suit the screw thread used, in the centre of each ebonite piece. The most convenient screws for the present purpose are No. 5 B.A., 1/2in. to 1in. long. For use in cases with four-hole fixing components, where two of the holes may not line up with the slots, make several small finger clamps 1in. to 1 1/2in. long by 1/2in. wide by 1/8in. thick from ebonite. Each one is drilled with a 5 B.A. clearance hole in the centre.



# Radio Wrinkles FROM READERS

### A Reaction Hint

WHEN reaction with a differential condenser is too "fierce," the necessity for removing some turns from the reaction coil can often be overcome by connecting a condenser of .0001 or thereabouts between the fixed plates which are earthed and the moving plates of the differential.

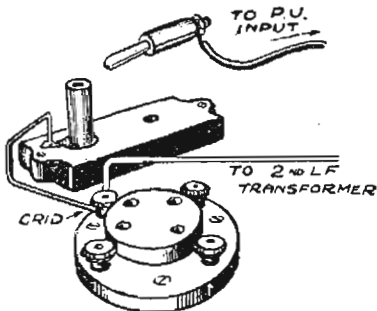

When using a pick-up in conjunction with two L.F. stages, the usual panel switch or jack arrangement for bringing the pick-up into circuit generally involves a long grid lead and return. This can be obviated by using two old plug-in coil-holders as shown.

### Faulty Potentiometer Contacts

IN cases where a potentiometer gives trouble, the fault is usually due to a bad sliding contact. One result of this is that either partial connection is made or there is no connection at all. If a high-resistance potentiometer which is faulty in this way is used, for instance, in a screen-grid circuit for volume control, you will get all kinds of erratic results, and sometimes no control at all. If the voltage on the screen is too high, you may get the set oscillating, or again the amplification may turn out to be poor.

It is surprising how often bad contacts are met with in the slider of the potentiometer (and also in a rheostat, for that matter), and it is worth while to examine the sliding contacts very carefully and make sure that they really do their job properly.

### Increasing Selectivity

ADDED selectivity can often be obtained by connecting a .0002 fixed condenser

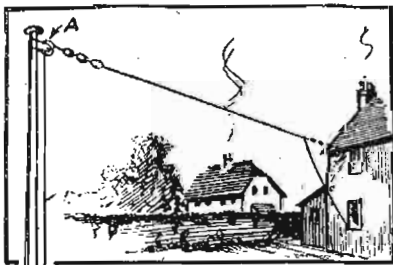

A single wire aerial suspended between the house and a wireless pole is subjected to strain when the pole sways in the wind. By fixing a pulley and weight at A and B respectively the strain can be obviated.

### THAT DODGE OF YOURS!

Every reader of "PRACTICAL WIRELESS" must have originated some little dodge which would interest other readers. Why not pass it on to us? For every item published on this page we will pay half a guinea. The items this week have been contributed, but in future we want readers of this paper to supply the items. Turn that idea of yours to account by sending it in to us, addressed to the Editor, "PRACTICAL WIRELESS," George Newnes, Ltd., 8-11, Southampton Street, W.C.2. Put your name and address on every item. Please note that every notion sent in must be original.

in the earth lead. This condenser may always be used effectively if the earth lead is long, or if it is ultimately taken to a water main. It reduces the net capacity of the aerial-earth system. It will also neutralise the effect of coupling by other sets which may be earthed to the same water main. It cannot be used in mains-operated circuits. In this case the capacity should always be placed in the aerial.

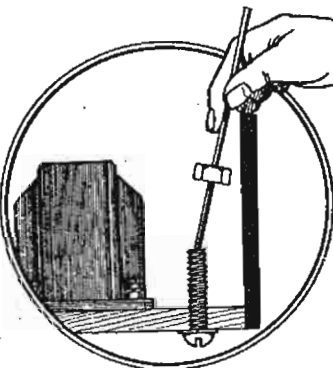

The wireless constructor who encounters difficulty in starting nuts in awkward places, will find the method shown above very useful.

### Improving the Layout

WHEN wiring a modern circuit it is not necessary to have all the controls on the front panel.

The main condenser knob should be at the front, but the volume control, wave-change switch and radio-gram switch can conveniently be at the side. facilitates wiring, too, one should avoid bring-

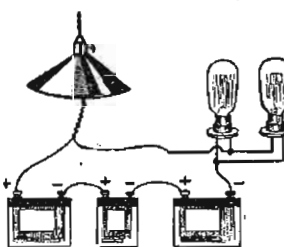

### Dual Capacity Batteries

WHERE possible, it is advisable to use dual capacity high tension batteries because they last more than twice as long as do the cheaper sort. The E.M.F. is greater and more constant. Consequently, tone is purer, and for reasons that can easily be understood, weak stations are received at greater strength.

By adopting the simple arrangement shown here, accumulators can be charged at home if your electric supply is D.C. The two lamps on the right are 60-watt lamps and are used as a resistance.

### Motor-Boating

THIS trouble, which often crops up in a set, is largely due to the regeneration being too acute, and to an excessive anode potential of the detector valve. In such cases this potential should be reduced. Another remedy is to use a low resistance

grid-leak—a 1-megohm, for instance. Sometimes the mere reversal of an L.F. transformer's secondary will stop the trouble, while in other cases "decoupling" is needed. This consists of inserting a high resistance of about 20,000 ohms, and a large-capacity condenser—2 mfd. in the detector circuit. The resistance is connected between H.T. and the primary of the L.F. transformer, and the condenser is inserted between this side of transformer primary and L.T. negative.

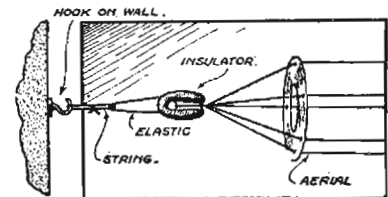

An indoor aerial can be prevented from sagging by attaching two pieces of strong elastic (one piece to each insulator) as shown above.

### Interference from Neighbouring Sets

TO minimize interference from neighbouring sets it is a good plan to arrange your aerial at an angle to the nearest aeri- als instead of parallel to them. An independent outside earthing should also be provided. It is better to use a capacity earth than to connect your set to a water main which may be used by dozens of others. If you cannot arrange an outside independent earthing, try connecting a .0002 fixed condenser in series with the earth lead.

### L.F. Instability

AFTER an H.T. battery has been in use for several months a set may develop a high-pitched whistle and reception becomes distorted. The reason is that the voltage of the battery has dropped, causing an increase in its internal resistance sufficient to produce instability in the L.F. amplifier. The addition of another battery in series with the old battery will not stop the trouble, as the resistance of the old battery remains the same. The remedy is to replace the old battery with a new one, and then the trouble will cease.

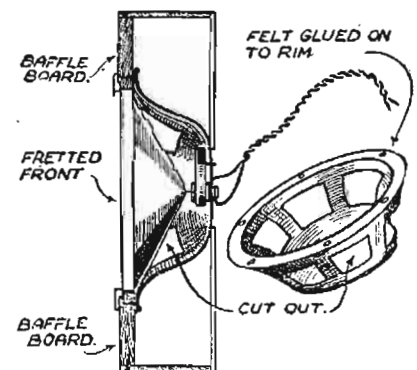

A reasonably good speaker—unit chassis can be made from an ordinary tin or enamel basin measuring 12in. or 18in. in diameter.

# THE LATEST KITS REVIEWED



THE well-known firm of Lissen, Ltd., have been making wireless components practically since the inception of broadcasting in this country, and their progressive policy has contributed in no small measure to the efficiency and

## THE LISSEN SKYSCRAPER

stage, the second stage is a Lissen Det. valve, and the output valve is the Lissen economy power pentode valve. The transformer is, of course, the well-known Lissen Hypernik. All of the components are mounted on an aluminium chassis, fitted with a neat and attractively finished panel.

### Fitted for a Gramophone Pick-up

The receiver is fitted for the use of a gramophone pick-up, and terminals are provided for the addition of an extra loud-speaker if required. The Consolette kit, complete with valves and a specially matched loud-speaker, costs £6 5s., and the table model £5 5s. The kit alone, exclusive of cabinet but complete with the three valves, costs 89s. 6d. I must accord my meed of praise to the cleverly-designed cabinet; it is well made and beautifully finished, and coupled with the very modern lines of the set itself it should meet the most exacting requirements.

### Over Forty Stations

Reverting now to my test, in one evening I received over forty stations, the weakest of them being at comfortable loud-speaker strength. Over a half of this number were foreigners, from which it will be gauged that the set reaches out. No difficulty whatever was experienced in separating any of the stations, either British or foreign, and in no instance did I experience jamming. The tuning is delightfully easy and selective—no finicky knob-twiddling—and the reaction is smooth; it does not come on with a bump, and weak stations can be "built-up" to comfortable volume without distortion and without working too near to the point of oscillation. I welcome the lead which Lissen have given in providing a complete kit—a much better arrangement than leaving the inexperienced amateur to choose his own valves, etc., only quite wrongly to blame the set when really the valves are to blame. I welcome, too, the provision of pick-up terminals, for more and more are listeners tending to combine radio with the gramophone.

I repeat—a splendid kit, which will satisfy the most exacting requirements.

F. J. C.

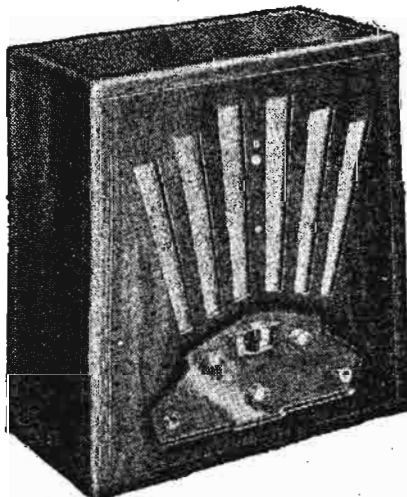

The attractive lines of the new Lissen Skyscraper Three Consolette may be gauged from this photograph.

reliability of the home-constructed set. It was, therefore, with pleasant anticipation that I erected the kit of components (complete down to the last screw) by means of the really well-done wiring diagram supplied with it. I should like to give a word of praise concerning the manner of presentation of this wiring diagram. Attractively produced in colour, a great amount of effort must have been put into it, and a mere glance at it suffices to indicate that the firm at the outset have intended to produce a thorough job.

### A Simple Set to Erect

It is but the work of an evening to erect the set, and it worked straight away without tedious tuning up. I gave a kit of parts to a raw amateur to erect, and in point of fact he had never made a set before. He had no difficulty whatever, and did not worry me as to where this or that went. Upon connecting the set on to my aerial I tuned in Regional at full volume, and it is in no sense of flattery, but purely because I wish to accord praise to a worthy article, that I say at once that this famous factory has really surpassed itself in producing the Skyscraper kit. Before continuing with my description of the actual test, may I explain that the Lissen Skyscraper constructor's kit employs the new Lissen shielded coil in conjunction with a screen grid detector and pentode circuit. A Lissen metallised H.F. valve is used in the first

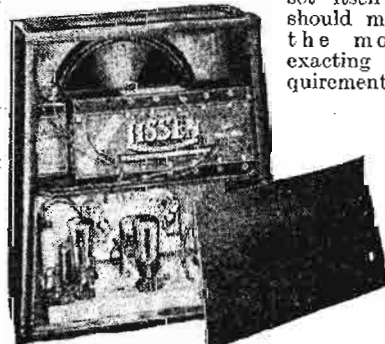

Rear view, showing battery space, built-in speaker, dual range shielded coil, Lissen valves, etc.

### KIT:

The Lissen Skyscraper.

### MAKERS:

Lissen Limited, Worple Road, Isleworth, Middlesex.

### SPECIFICATION:

All-metal chassis, shielded coils, screened grid, detector and pentode valves, metal panel, two styles of cabinet—all-in Consolette and Table model. Pick-up terminals fitted. Complete with valves, matched speaker and cabinet (walnut). Constructional chart in two colours included.

### PRICE:

Consolette, £6 5s., Table Model, £5 5s. Kit only (including valves), 89s. 6d.

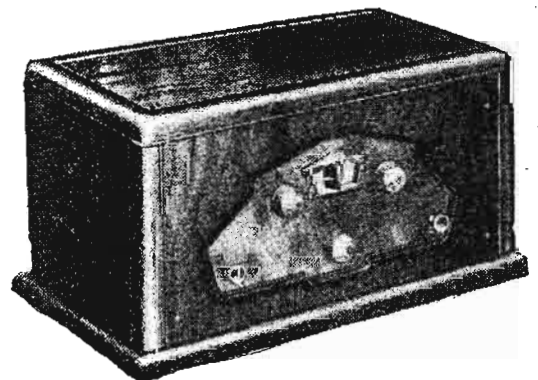

Another style of cabinet for the Lissen Skyscraper—the Table Model.



# THE "DOLPHIN"

A splendid economy receiver, on modern lines, with extremely selective, and will reach



Fig. 1.—The set is housed in a cabinet constructed on modern lines, including a sliding frame, space for speaker, batteries and accumulator.

THE most remarkable thing about this set is that in spite of the fact that it has not an "ode," "dyne," "stat," or any other fancy suffix, and probably because of its very simplicity, it yields remarkable results. Not only is it simple to operate and simple to build, but it is certainly cheap, up to date, and selective. I do not claim for it that it will do all that our Long Range Express will do, for that is a star set designed to satisfy the most meticulous home constructor. The difference between the two sets is that this will not give a greater output than about 230 milli-watts, and as such it is not suited for use in conjunction with a moving-coil speaker. With the speaker which we have selected, however, ample volume may be obtained, and I can recommend its construction with every confidence. You will be amazed at the manner in which the set will reach out for a fair distance on to the Continent, for most of the foreign stations ordinarily required by the listener are brought in with a minimum of knob-twiddling.

Before proceeding with the description of the construction, a word or two about the cabinet is necessary. This is of Clarion manufacture, and, designed on modern lines, includes a complete slide-in frame upon which a frame aerial may be wound.

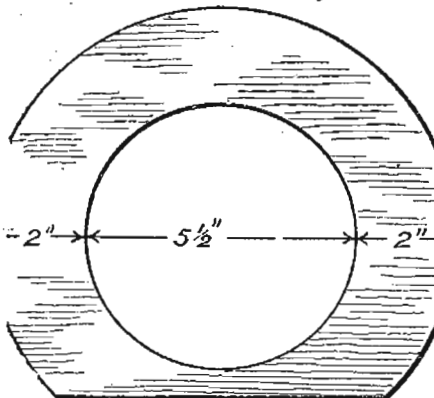

Fig. 7.—Details of the speaker baffle.

Certain modifications, of course, would be necessary to render the set suitable for frame aerial reception. This is a matter, however, we hope to deal with next week.

Owing to the minimum number of components included, the wiring will be found practically "fool-proof"; owing to the limitation in the number of control knobs, the tuning-in of stations will also be found "fool-proof"; and, finally, owing to the type of intervalve couplings which have been included, the quality of the reception will satisfy even the most critical listener.

The first inter-valve coupling includes, besides the usual L.F. transformer, two additional components, which remove a certain amount of external wiring. In addition, the method of connection employed in the component enables a high standard of quality to be obtained.

The coil includes a wave-change switch, an on-off switch, and a variable selectivity (or volume control) device. These three controls are combined in the one knob. It will be seen, therefore, that although the circuit consists of the rather orthodox detector and 2 L.F. arrangement, there are sufficient novel features included in the receiver to

of the wiring is carried out. Note that a small hollow must be filed in the lowest portion of the terminal block carrying the pick-up terminals. This hollow should be just large enough to hold the battery cords firmly in position. Mark out and drill the panel in accordance with the panel lay-out, and then attach the two condensers by means of the fixing bushes. No problems of any kind should have arisen so far, and the receiver is now ready for wiring, a process which will take a little longer than the previous part of the work, and one which will require just a little care, although it will not be found actually difficult.

### Wiring

In any receiver it is always preferable to wire up in a systematic manner rather than by just putting in a wire here, and then another wire there. Personally, I have always adopted the procedure of wiring low potential parts first, then wires carrying high voltages, and so on. I would therefore suggest that the same idea be carried out in this set, that is, wire the filament leads first, then the leads to grid and plate terminals, and so on; as each wire is put into its place, cross out the corresponding wire on the wiring diagram. By working in this fashion one is assured of putting each wire in its correct position, and when the job is finished no wires will be found to have been omitted or put into the wrong position. Note that one terminal on the transcoupler is not used in this particular circuit arrangement.

### Complete Wiring Diagram is on page 13.

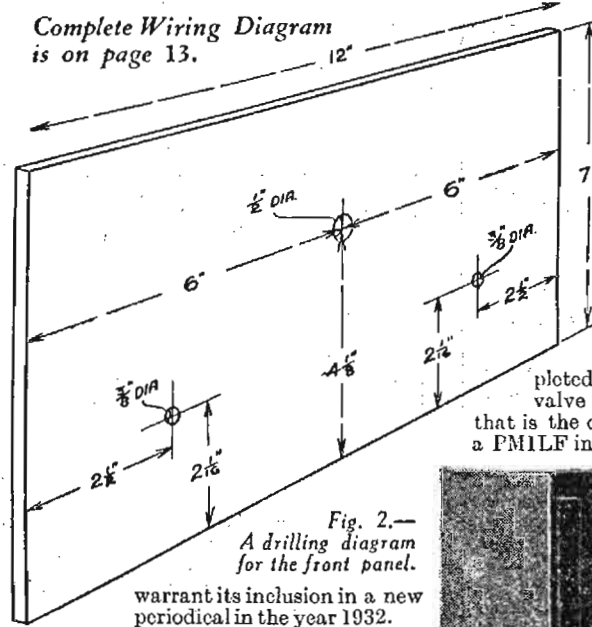

Fig. 2.—A drilling diagram for the front panel.

warrant its inclusion in a new periodical in the year 1932.

### Construction

Having described the special features of the receiver, we may now get down to the description of its construction, and even the beginner will find no difficulty in following the instructions given below.

First of all lay out the various components on the baseboard in the positions shown in the wiring diagram. Note the arrangement of the two inter-valve couplings before screwing them down, so that the wiring will be correctly carried out without, for instance, having to remove one of the transformers and turn it round. It is little points like this that sometimes make the construction of a receiver irksome. Do not drive in a single screw until you are quite certain that each component is in its correct position, and the right way round. In this particular receiver all the components may be screwed down before any

### Testing Out

When the wiring is completed, plug a Mullard PM2DX valve into the detector valve-holder, that is the one in front of the tuning coil; a PM1LF into the next holder, and a PM 2

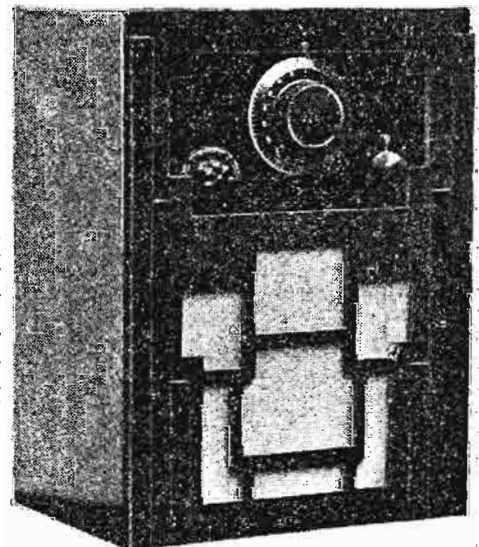

Fig. 3.—A three-quarter front view of the set showing the attractive lines of the cabinet, and the operating controls.

# STRAIGHT THREE

many novel features. Cheaply constructed, it is out in an astonishing manner

into the remaining holder. A 2-volt accumulator is used with these particular valves, and the two L.T. leads should be joined to the positive and negative terminals of the accumulator. The H.T.1 lead should be plugged into the 90-volt tapping on the high tension battery, and H.T.2 into the 120-volt socket. The grid bias is also a critical adjustment, and the valves recommended by the valve-makers for the voltages applied in this particular circuit are 4.5 volts for G.B.1 and 9 volts for G.B.2. By using these values you will be assured of quality and long life to the valves. Attach a loud-speaker to the L.S. terminals and you are ready to tune in. The knob on the left of the panel should be turned as far as it will go to the left when the set is not in use.

By  
F. J. CAMM.

Next  
Week:

"WHAT THE  
DOLPHIN WILL DO."

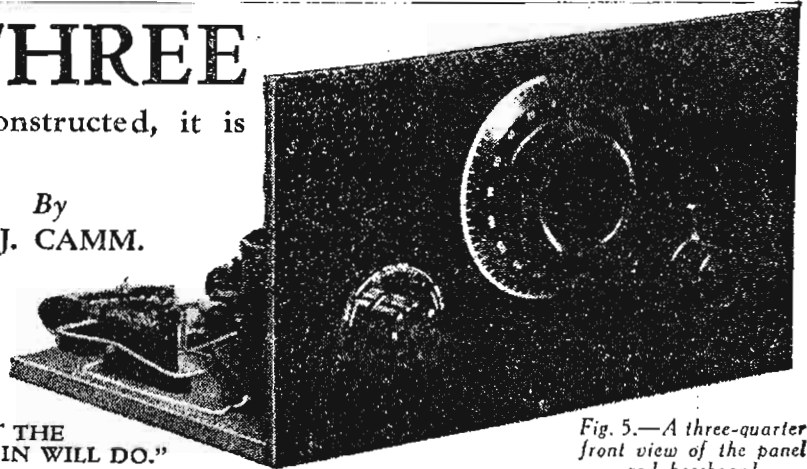

Fig. 5.—A three-quarter front view of the panel and baseboard.

increase the strength of the stations. Having rotated the tuning dial to the end of its scale, advance the left-hand dial a few degrees farther to the right, and again run round the tuning dial. You will find now that other stations are audible owing to the increased coupling afforded by the aerial coil. When the left-hand dial is rotated

a wavelength rather close to our own high-powered stations, a balance has to be struck between the left-hand knob and the right-hand one. In other words, the selectivity has to be increased to enable the station to occupy a very narrow band on the dial, and this naturally reduces the strength. Then the reaction control has to be employed to build up the

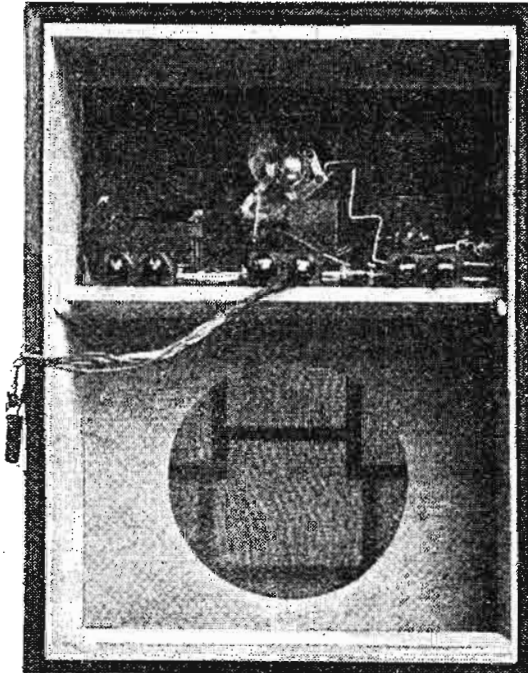

Fig. 4.—A rear view of the set showing the fillet supports for the baseboard and the roomy compartment for the speaker and batteries.

### SPECIFICATION FOR THE "DOLPHIN" STRAIGHT THREE.

- |   |  |
|---|--|
| 1 Ready Radio Dual-range Coil Unit  | 4 Clix Wander Plugs, G.B. —, G.B. —1, G.B. —2, G.B. +. |
| 1 Jackson Bros. J.B. .0005 mfd. Variable Condenser, mid-log line, with slow-motion dial.  | 1 Permcoll Ebonite Panel, 12in. by 7in.                |
| 1 Igranic .00015 mfd. Reaction Condenser.   | 1 Wooden Baseboard, 12in. by 8in.                      |
| 1 Bulgin Transcoupler.  | 2 Bulgin Panel Mounting Dial Pointers.                 |
| 1 Slektun Colt 5-1 L.F. Transformer.  | 1 Coil Lewcos Glazite.                                 |
| 3 W.B. 4-pin Valve-holders.   | 1 "Motor" S.40 Super Power Unit with Cone.             |
| 1 T.C.C. .0002 mfd. Fixed Condenser, three-terminal type.                                 | 1 Ever Ready 2-volt 40 ampere hour L.T. Accumulator.   |
| 1 Lissen 2-meg. Grid Leak.  | 2 Ediswan 60-volt super-capacity H.T. Batteries.       |
| 3 Belling Lee Terminal Mounts.  | 1 Lissen 9-volt grid bias battery.                     |
| 6 Belling Lee Terminals (Aerial, Earth, Loud-speaker +, Loud-speaker —, and Two Pick-up). | 3 Mullard Valves, PM2DX, PM1LF, PM2.                   |
| 1 Belling Lee 5-way Battery Cord.   | 1 Clarion "Dolphin Three" Cabinet.                     |

completely to the right the receiver is automatically tuned to the long wave band, and Daventry, Radio-Paris, Hilversum, and other long-wave stations will be heard.

On the normal waves, in order to listen to some of the weaker foreign stations which transmit on

strength again, and in this way it is possible to hear such stations as Langenberg, for instance, without any background from the Northern Regional.

If you are situated very close to one of our main stations, you may find it advantageous—from the point of view of avoiding distortion due to overloading—to use, in

In this position the valves are turned off. Now turn this knob a few degrees to the right and the receiver is switched on, and is in its most selective condition, which means, of course, that signals will be at their weakest. Rotate the centre dial, which will enable you to tune to various wavelengths, and you should soon be able to hear your local station, which you will find will only occupy a very small space on the tuning dial. You may be in a good district, and be able to hear two or three stations with this particular setting of the first dial, and without the use of the third or right-hand dial. This controls the reaction condenser and serves to

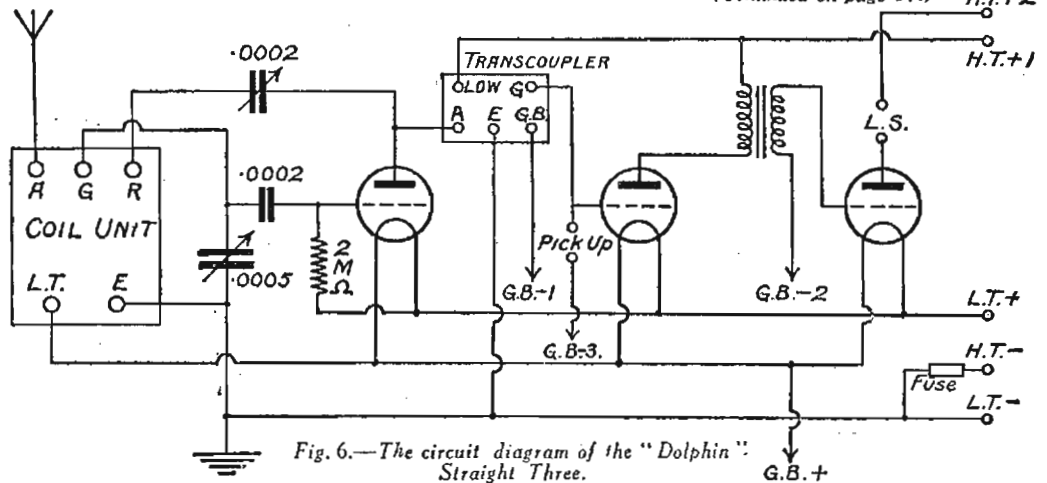

Fig. 6.—The circuit diagram of the "Dolphin" Straight Three.

(Continued on page 17.) H.T.+2

H.T.+1

L.T.+

H.T.—

L.T.—

L.S.

Fuse

G.B.+

# WIRING DIAGRAM OF THE "DOLPHIN" STRAIGHT THREE

Simplicity of wiring, ease of operation, cheapness of construction, excellent selectivity, and fair range of reception are some of the characteristics of this set. Full details are given on pages 12, 13 and 17.

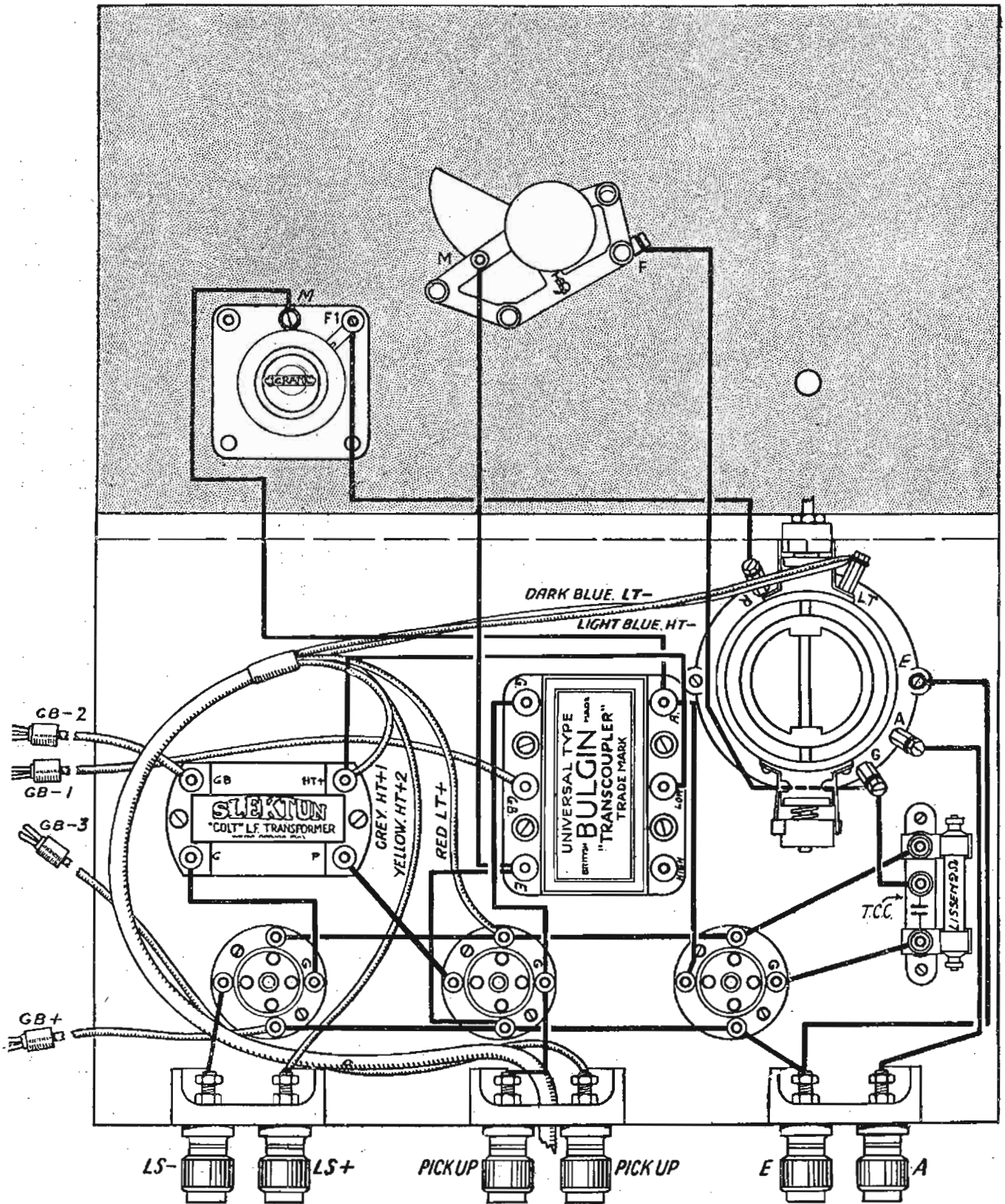



**THE  
GREAT LITTLE  
TRANSFORMER**  
*Specified*  
*for the*  
**DOLPHIN STRAIGHT  
THREE**

WHERE ONLY THE  
BEST WILL DO

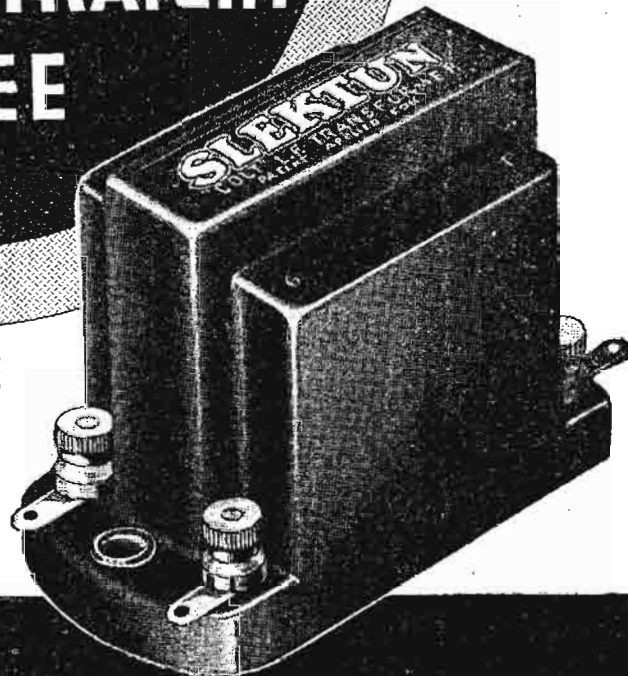

**SLEKTUN**  
**COLT TRANSFORMER**

● You cannot obtain anywhere, at such a moderate price, a more dependable transformer than the Slektun Colt.

It has been specified by many well-known designers for its sound construction and its unvarying quality reproduction.

For years of faithful service choose Slektun components always. They will give you better results and complete satisfaction.

**4/9**

RATIOS 2-1, 3-1, 4-1, 5-1

**FOR BETTER  
RESULTS USE**

Slektun  
L.F. Transformers  
H.F. and L.F. Chokes  
Mains Transformers  
Loud-speaker Units,  
etc.

All Good Radio Dealers Stock "Slektun" Quality Radio Components. In Case of Any Difficulty Write Direct To:  
**SLEKTUN PRODUCTS LTD., 21 DOUGLAS STREET, WESTMINSTER, S.W.1**

# CONSISTENCY

*Below is an enlarged section of a Cossor A.C. Mains triode—the 41 M.H.L. The use of two Mica Bridges ensures life-long alignment of the elements. Note the "cut-away" view of the cathode, showing the heater wire in position.*

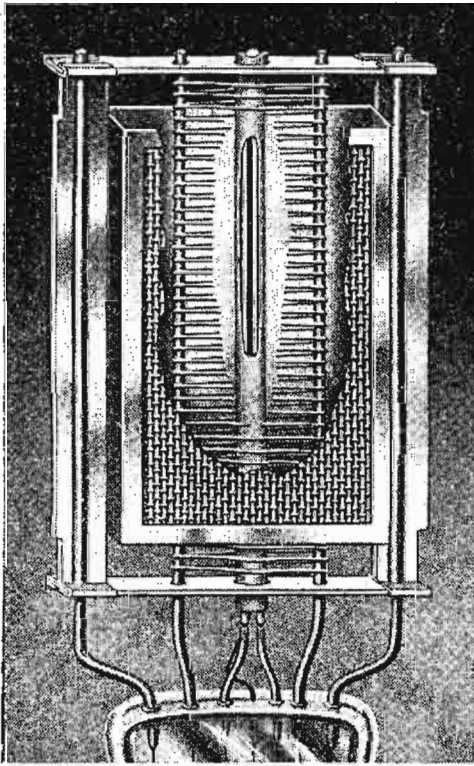

To Messrs. A. C. Cossor Ltd., Melody Dept.,  
Highbury Grove, London, N.5.

Please send me, free of charge, a copy of the  
72-page Cossor Valve Catalogue, B.14.

Name.....

Address.....

PRAC. 24/9/32.

The employment of Mica Bridge Mounting in Cossor Valves ensures microscopic accuracy in the assembly of the electrode system. As a result the characteristics of every valve are identical with those of the original design developed in the laboratory. Variation is impossible. The performance of each valve is therefore safeguarded—the Mica Bridge is a virtual guarantee of performance and reliability.

## SPECIAL OFFER

Send for a free copy of one of the most comprehensive valve catalogues ever published. This, the Cossor 72-page Valve Catalogue, contains full technical data, characteristic curves, operating conditions etc., of all types of Cossor Valves. Please use the coupon.

# COSSOR VALVES

A. C. Cossor Ltd., Highbury Grove, London, N.5.  
Depots at Birmingham, Bristol, Glasgow, Leeds, Liverpool,  
Manchester, Newcastle, Sheffield, Belfast and Dublin.

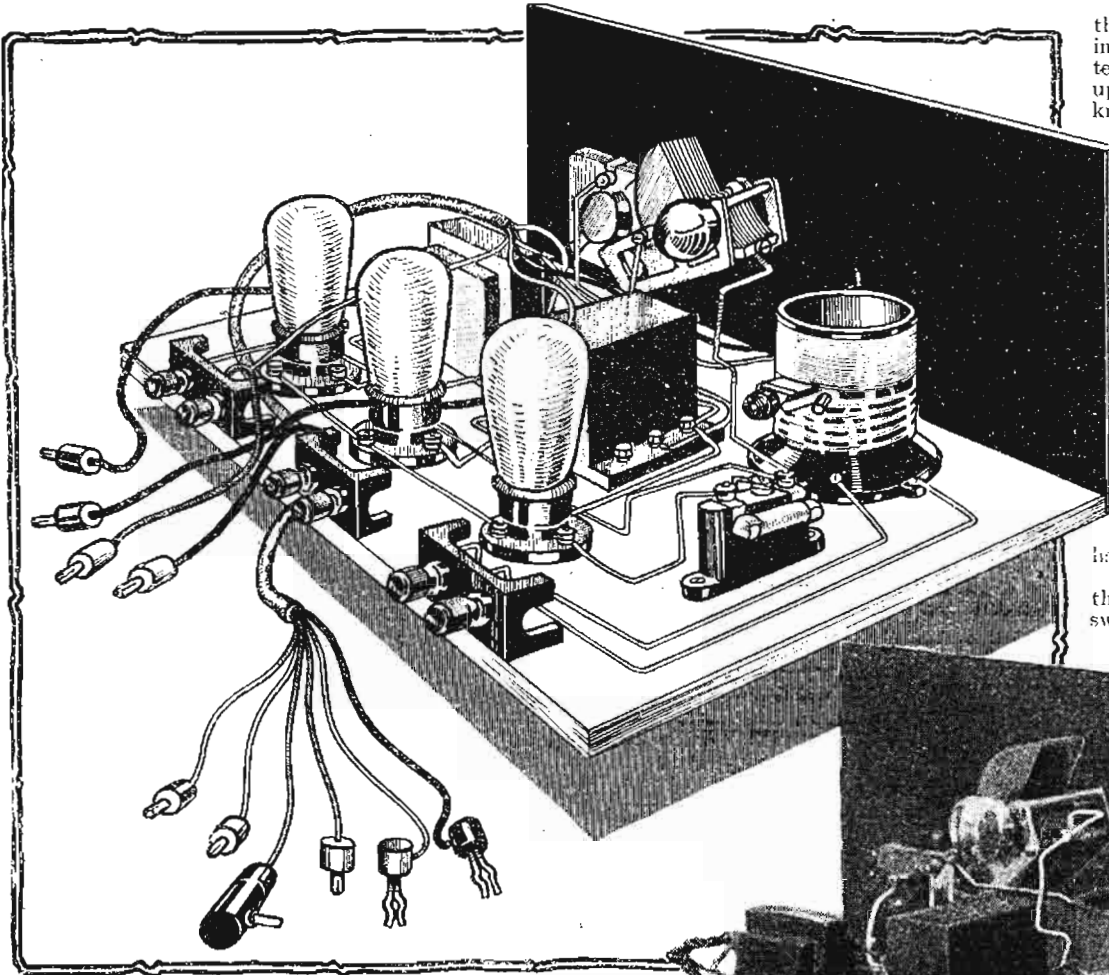

the other terminal is joined in the receiver to the grid terminal. When the pick-up is in use, the control knob on the coil unit must be turned to its most selective position—that is, just as far as the first marking on the selector scale. There will then be no risk of the wireless programmes being heard in the background. If the pick-up is very sensitive, a volume control will have to be used to reduce the output from the pick-up to a level which can be safely handled by the P.M.I.L.F. Do not forget to rotate the left-hand knob to switch off.

(Continued from page 13.)

place of the P.M.2 valve, a larger power valve such, for instance, as the P.M. 202, or even the P.M. 252. With these valves a greater output is naturally obtainable, but it must be borne in mind that the high-tension consumption will be increased and this will destroy one of the features of this receiver—economical running.

It will be noticed that two pick-up terminals are provided in the centre of

the baseboard. The bias lead from one of these terminals must be inserted into the grid battery at about 6 volts, whilst

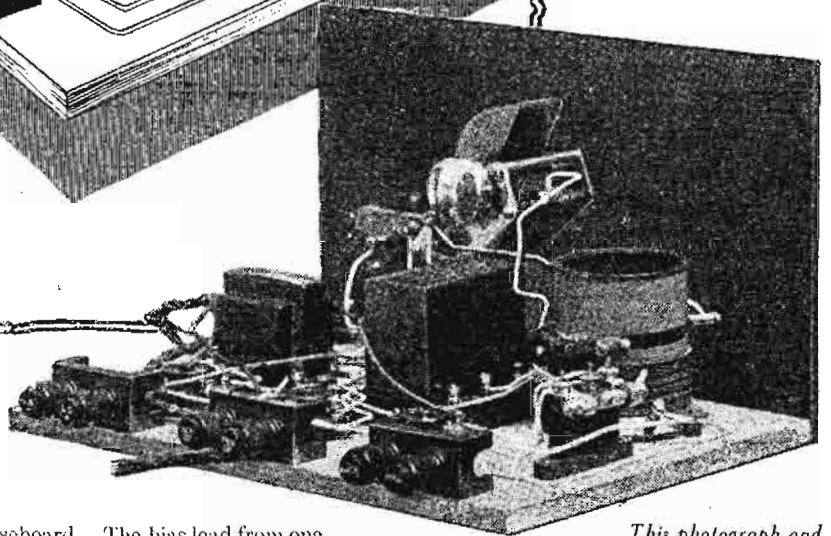

This photograph and drawing show the Dolphin in three-quarter rear view.

**Shielding Transformers**

Many transformers and chokes are supposed to be sufficiently shielded by their own covers, but it is often found in practice that these covers are sadly lacking in shielding properties. One result of this is that in a mains-operated set, you will get a hum owing to the circuits interacting with one another.

To properly serve as a shield the cover of the component should be of much thicker material than that generally used. The usual precaution to place transformers—for instance, the power transformer and any near-by inter-valve transformer—at right-angles to one another goes a long way to avoiding trouble, however, and if you are not sure about it you might try connecting the inter-valve transformer by means of leads a few inches long, so that you can shift it about and turn it in different positions until you get the best result.

**A Fuse Tip**

In many sets a flash-lamp bulb is connected between the H.T. negative and L.T. negative to act as a fuse. Sometimes this bulb is "fused" and a spare one is not at

**PRACTICAL PARS**

hand when the set is wanted in a hurry for a particular item. In such cases there is no need to short the bulb holder or to alter the wiring of the set. All that is necessary is simply to remove the wire connecting the negative of the H.T. battery to H.T. negative terminal from this terminal, and join it instead direct to the L.T. negative terminal.

**Loud-speaker Hints**

It is a good plan to go over the loud-speaker occasionally and to tighten up all nuts, screws and terminals. If any of these are loose all sorts of rattles may be set up.

"Boomy" results from a loud-speaker are sometimes due to cabinet resonance, and a good way of overcoming this is to

pack the interior surfaces of the cabinet with sound-absorbing material such as thick felt.

In cases where the loud-speaker is totally enclosed in a cabinet of the console type, improved results can often be obtained if a large hole—about 6ins. diameter—is cut in the back of the cabinet. It can be covered, on the inside of the cabinet, with tinsel gauze like the speaker fret.

**Smoothing Reaction**

For short-wave working smooth reaction is essential, for on this the entire sensitivity of the set depends. Incorrect operating conditions of the detector valve usually causes "ploppy" reaction, and to remedy this try a lower plate voltage—not more than 60 volts should be needed with the average detector.

If this does not cure the trouble it may be that the positive bias on the grid of the detector, as applied through the grid leak from the positive side of the filament battery, is too great. Try a higher value of grid leak. Anything up to 5 megohms is suitable for short-wave working, with a 0.003 micro-farad fixed grid condenser.

A WEEKLY FEATURE

# Tested ON OUR AERIAL

TEST REPORTS OF COMPLETE RECEIVERS  
BY THE TECHNICAL STAFF

We shall be glad to advise readers concerning the purchase of complete sets.



## THE LOTUS "BUD" A.C. MODEL

17in. high by 5in. deep, houses the set. A fretted aperture (in simulation of the Lotus flower) occupies the top front portion. Immediately below which is situated a neat metal escutcheon plate finished in "Cornish Bronze." The tuning dial is of the drum type horizontally disposed, and a generous part of the milled edge projecting makes this control particularly pleasing to handle. The "on-off" snap switch is arranged underneath on the same plate. On the left and right of this, respectively, are the "long-short" wave switch knob and volume control knob.

## NEXT WEEK: THE VARLEY D.C. MODEL

The back of the cabinet is removable by releasing two flush-fitting bolts. Along the bottom of this side are arranged earth socket, mains plug, mains aerial plug, two aerial sockets and a selectivity control.

A well-tried straight circuit is employed, a low damping detector and 4 electrode power valve with an output of 900 milliwatts A.C. being incorporated.

An all-metal Westinghouse rectifier is followed by a very efficient smoothing arrangement, and the Magnavox moving coil loud-speaker is provided with sockets for attaching an independent speaker. By moving a plug into one of three sockets at the base of the mains transformer, the set is readily adjustable for use on supply voltages of 200 to 250 and over. Both mechanically and electrically the whole assembly is a good sound job.

The primary intention of the designers was to produce a set that would give perfect reception of a few stations, and the number of listeners whose requirements are thus fulfilled must be considerable.

We had the pleasure of testing an A.C. model of the Lotus "Bud" taken at random from stock. It was tested

approximately twenty-five miles from London, and, notwithstanding the conservative aims of the designer, the reproduction of both speech and music, vocal and instrumental, was unusually clear, with complete absence of mains noises or interference from other stations, and the volume strength was truly robust, free from resonance, and pleasing to the ear. Without using an outdoor aerial, that is, by transferring the mains aerial plug into one of the aerial sockets at the rear of the set, perfect reception of the National, London National, and London Regional programmes were obtainable. This consideration should be of especial interest to residents on premises where the erection of an outdoor aerial is a practical impossibility. The quality when using an outdoor aerial was equally as good, two aerial lead sockets being fitted, one for maximum volume and the other for use in conjunction with the selectivity control. Several Continental stations were tuned in, notably Radio-Paris, Königs Wusterhausen, Huizen, Eiffel Tower, Strasbourg, Toulouse, Prague, Copenhagen, and Budapest. The total number of stations logged was much in excess of this.

To those who are looking for a receiver of this description, this one can be thoroughly recommended. The capabilities must be heard to be appreciated, and will soon convert the listener to an enthusiastic owner. The valves are Mazda A.C./2H.L. and Cossor 41 M.P.

The price of the A.C. model is 10 guineas, and that of the D.C. model is 11 guineas, these prices include royalty.

THIS splendidly-made instrument is a product of the well-known firm of Lotus Radio, Limited, of Mill Lane, Liverpool, makers of high-class sets and components, whose claims regarding this model were, under test, more than justified.

The "Bud" is a 2-valve all-electric receiver, and is available in types suitable for either A.C. or D.C. current supply. An attractive walnut case, the approximate dimensions of which are 14in. wide by



The Lotus suitcase portable S.G. four, which costs £12-12-0.

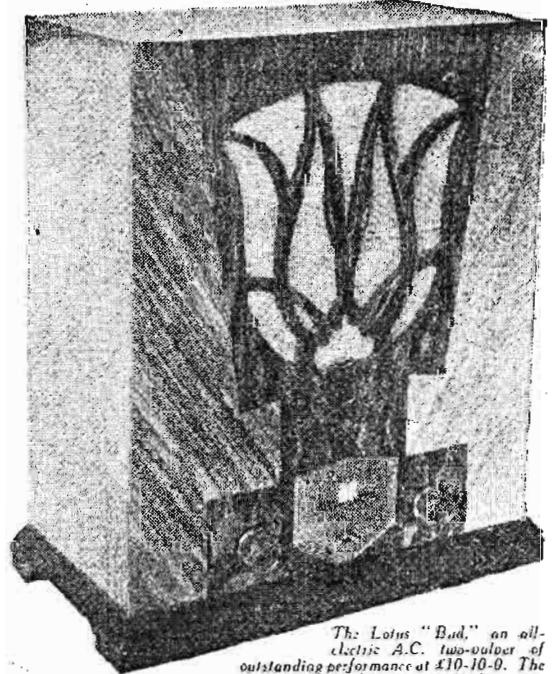

The Lotus "Bud," an all-electric A.C. two-valve set of outstanding performance at £10-10-0. The D.C. model costs £11-11-0.



# When the higher notes are missing —RECTATONE restores them.

## OVER 1,000 CYCLES—A RISING CURVE

The growing ether congestion calls for still more selectivity. The super-heterodyne and special ultra-reaction circuits have been developed to meet this requirement, the tuned circuits being made sharply resonant, deliberately cutting off the high notes. It is clear that a low-frequency coupling device is required which will restore these weakened high notes to their correct value. The new **RECTATONE** transformer does this. Its frequency response curve is straight up to 1,000 cycles per second and then rises, reaching a maximum at approximately 4,500 cycles.

## RECTATONE, THE IDEAL L.F. COUPLING

The degree of compensation is variable and may be suited to the particular tuned circuits in use or employed to correct deficiencies due to the loud-speaker or to the acoustics of the room. **RECTATONE** is thus the ideal L.F. coupling for all selective sets—particularly useful for those using a pick-up or for radio-gramophones, since the tone control so valuable on radio can be cut out on "gramophone" where it is usually unnecessary.

## THE NEW RECTATONE L.F. TRANSFORMER

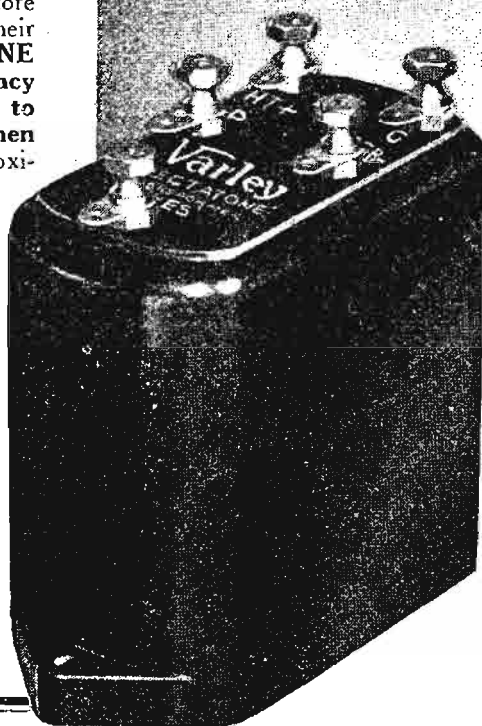

List No. DP.33.  
Ratio - 7 : 1.

Compensation is controlled by a variable resistance of about 5,000 ohms connected externally between the terminals H.T. + and RES. With a pentode output valve a 2,000 ohm fixed resistance may be connected in series with the variable resistance in order to prevent excessive amplification of high frequencies with consequent liability to self-oscillation.

# FREE BOOKLET



Proprietors: OLIVER PELL CONTROL LTD.

*When bass and treble are correctly present, Rectatone preserves them . . . . . When the higher notes are missing, Rectatone restores them.*

To Messrs. Varley, Kingsway House, 103 Kingsway, London, W.C.2.  
Please send me, free and post free, the  
**"BOOK OF THE RECTATONE"**  
Date.....  
Name .....  
Address .....  
..... Pr. W.I.

# THE NEW RANGE OF REGENTONE MAINS UNITS



# 5 STAR FEATURES

## ONLY ON REGENTONE

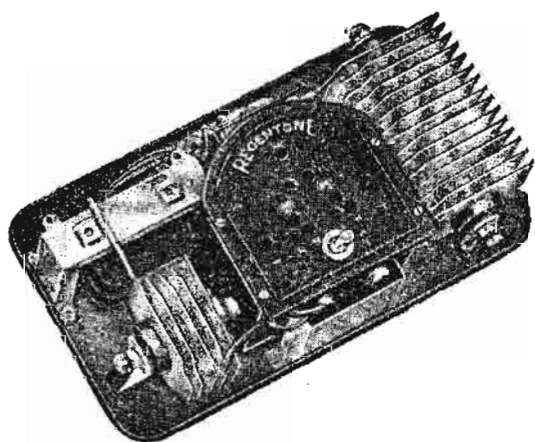
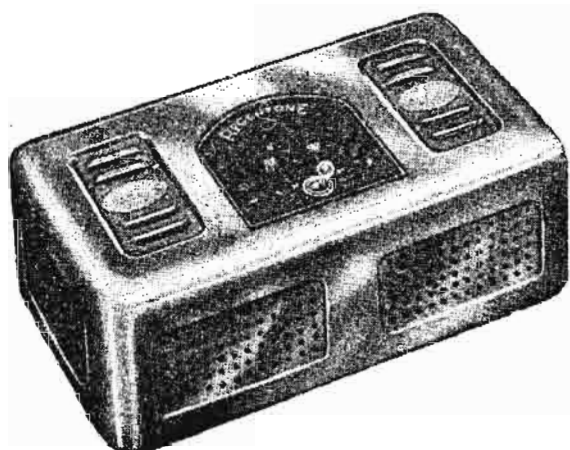

The incomparable range of Regentone Mains Units entirely redesigned. Each Mains Unit now incorporates these five star features.

Each model is housed in a solid drawn steel case, of most attractive design having a Florentine bronze finish.

Each and every model is provided with tappings divided into three main groups; SCREEN GRID, DETECTOR AND POWER. The Screen Grid and Detector supply each have high, medium and low outputs. The power supply has one output only. SEVEN VOLTAGE TAPPINGS ARE COMMON TO ALL MODELS. All mains units incorporate a LINE VOLTAGE REGULATOR, by means of which voltage fluctuations in the main supply line can be compensated.

The Line Voltage Regulator and voltage tappings are carried by a specially moulded distributing block; the sockets carrying voltage are sunk into the insulating medium.

For supply and voltage as follows 200/250 volts, 100/120 volts, at 40/100 cycles. Dual frequency 25/50 cycles at an extra charge of 10/-. Prices from 39/6 or 8/- down.

Change from battery to mains  
but change with Regentone  
—and follow the experts

If you have a battery operated receiver, make it all electric with one of the new Regentone Mains Units. Regentone Mains Units are specified by famous set manufacturers for their sets; experts choose them for star circuits, the Press pays tribute to their efficiency and reliability. Choose Regentone—the one the experts all recommend.



THE SYMBOL OF INDIVIDUAL CRAFTSMANSHIP

Regentone, Ltd., Regentone House, 21, Bartlett's Bldgs., Holborn Circus, E.C.4. Tel. Central 8745 (5 lines). Irish Free State Distributors: Kelly & Shiel, Ltd., 47, Fleet St., Dublin.

# RADIO FADS AND FALLACIES

In this interesting article W. B. C. Richardson explodes some commonly-

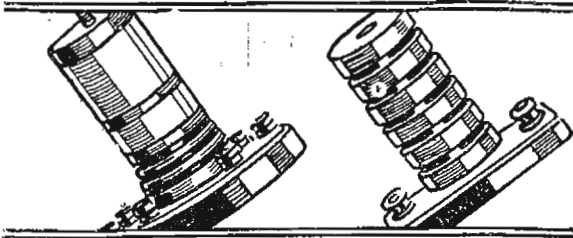

When is a coil not a coil?  
Left is a modern diminutive coil and right an H.F. choke.

accepted  
notions  
about  
wireless

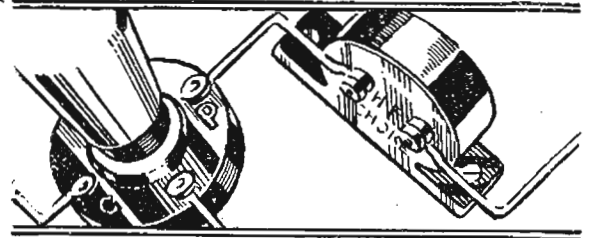

Why always put an H.F. choke in the plate circuit of the detector valve?

**H**AVE you ever noticed the number of erroneous ideas which are prevalent amongst radio enthusiasts? Even the most intelligent seem to be burdened with them, designers and manufacturers being no exception. For instance, most designers maintain that fairly thick wire should be used for connecting up receivers. This is usually quite unnecessary in any but short-wave sets. It stands to reason that if a tuning coil is wound with, say, 28 or 30-gauge wire it is stupid to use 16-gauge wire to connect it up. The reduction in H.F. resistance would be infinitesimal.

### Coils in Cans

We are told that since H.F. currents travel only on the surface of the wire, we should have multiple strand aerial wire and thick connecting wire. However, when we come to buy an efficient tuning coil to connect in series with our aerial we are sometimes presented with a gadget in a can consisting of a coil of very fine wire wound round a small bobbin, much like an H.F. choke. The point is that both designers and constructors are not consistent. Surely if we desire a really efficient aerial-earth system the wire of aerial, earth, and coil should be of the same gauge. Of course, we all know that reaction will overcome the H.F. resistance of a coil, and that is no doubt why some very inefficient types are able to work at all. Another point in connection with the aerial and tuning system is that usually the most efficient condensers, namely, air dielectric, are used for tuning, that is, connected in parallel with the coil, whereas any old solid dielectric condenser is connected in series with it as the selectivity device. If we are loth to put a resistance across the coil, why put one in series with it? That's what it amounts to.

### H.F. "Choke" or "Joke"?

If you look at the circuit diagram of any receiver published during the last three or four years you will notice that almost invariably an H.F. choke is included in the plate circuit of the detector valve. It is usually the more rubbishy type of choke which is reserved for this position, and the fact that the set works well with it is not because of the presence of the choke, but because it makes no difference! With two-valve sets and most three-valvers it is quite unnecessary to include a choke. The only difference it makes, if any, is to cause the oscillation point to occur on a slightly different setting of the reaction con-

denser. In the few cases when it really is necessary to by-pass the H.F. component of the rectified current the proper arrangement is a good choke and a condenser across the plate and filament of about .0003 mfd. This latter provides the alternative path when the reaction condenser is at a minimum setting. The use of a differential condenser has the same effect. When the reaction is retarded, that is, when the capacitive coupling between the plate and the reaction coil is reduced, the capacity between the plate and earth direct automatically increases and so provides another path for the H.F. currents. In spite of popular belief I have never found that a differential condenser gives smoother reaction control. Correct biasing of the detector grid by means of a potentiometer will do that.

being missed. "Straight line" condensers do somewhat the same thing. You have probably noticed that a constant increase of capacity across the tuning coil does not mean a constant increase in wavelength. The increase in wavelength gradually becomes less. With a circular condenser this means that when tuning-in to a series of stations equally spaced as regards wavelength, they will come in crowded together at the bottom end of the dial and spread out at the top end. The straight line type of condenser compensates for this by giving only a slight increase of capacity for each degree of movement at the lower end of the scale, thus a greater movement of the dial is required to tune from one station to the next than with the circular type. It spreads the stations wider apart on the dial only. It cannot alter their wavelength, so that if they overlap one another when using a circular condenser they will still overlap on a square law or kilocycle condenser.

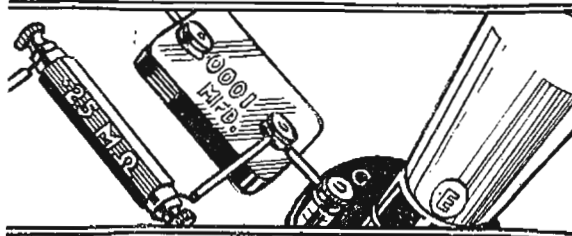

Power-grid detection does not make weak signals powerful.

### Limits of Slow-Motion Dials

Mention of controls reminds me that many amateurs still think that a slow-motion dial will give them more stations, and that the kilocycle and square law type of condensers, by spacing out the stations, will provide greater selectivity. Actually, of course, slow-motion devices merely enable the ham-handed to move the condenser round slowly instead of in a series of jerks and thus lessen the risk of a station

### Misleading Terms

I think the indiscriminate use of the word "power" in radio nomenclature has been responsible for many false ideas amongst amateur constructors. Take, for example, "Power grid detection." What a fine-sounding phrase to mislead the non-technical! I seem to hear the novice saying naively: "Ah, I must have that and make my set more powerful!" Actually, of course, it does nothing of the sort. It merely prevents overloading of the detector valve when receiving very loud signals. It does not make the signals louder, but prevents distortion if they are already loud, either through close proximity to a broadcasting station or through pre-detector amplification. The terms "power valve" and "super power valve" provide similar examples. There are quite a number of people who firmly believe they will get more power from a small set by using a super power valve, whereas an L.F. or small power type would give the greatest signal strength owing to its higher amplification. Here, as in the previous case, "power" signifies "power handling" and not "power producing," as we are so often inclined to assume.

LET OUR ADVICE BUREAU  
SOLVE IT FOR YOU! See page 65.

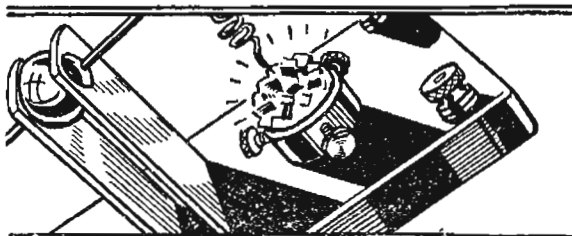

The greater "clearness" of crystal detection is a fallacy. A valve is just as clear if the volume is cut down to that of the crystal.

### Batteries Full of "Volts"

Perhaps you will forgive me if I bring up once again the somewhat hackneyed subject of worn-out H.T. batteries. Yet there are users who, when they find the voltage of their battery has dropped from 100 volts to about 60 volts, will purchase a

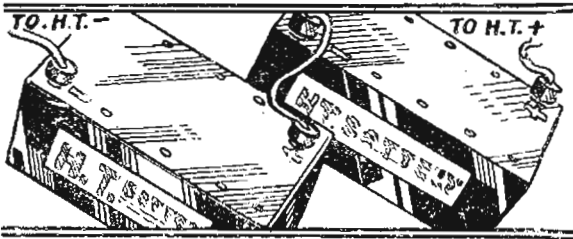

You cannot make a silk purse out of a pig's ear!  
Two old H.T. batteries joined together do not equal a new one.

new 60-volt battery and connect it in series with the old one with the idea that they now have the equivalent of a new 120-volt battery. To these persons an H.T. battery is full of "volts" and nothing else. So long as the volts manifest themselves on the meter they feel perfectly content. It is current and not "volts" that one takes from the cells, just the same as we take water and not pressure from a tap. When the battery is old it has a very high internal resistance which, to continue the analogy, is like a stricture in the water-pipe. If we put our thumb over the opening of the tap we can feel the pressure, but as soon as we take it away the water, instead of flowing out copiously, just dribbles out owing to the stricture. By substituting "voltage" for "pressure," "resistance" for "stricture," and "electrical current" for the "flow" or current of water, I think you will see what I mean.

Another practice which might at first sight appear quite in order is that of joining two batteries in parallel, that is, connecting the two positive sockets together and the two negative sockets together, and using the whole as a substitute for a "super" battery. This is all very well

resultant battery, instead of having the capacity of one new battery plus that of one old one, is now no better than an old one!

**Some Fads**

I am afraid I have not so far stuck to my title by serving up any fads to go with the fallacies. However, here are one or two: Firstly, there is the practice of switching off the set instantly there is the slightest sign of thunder or even atmospherics. Of course, it is safest to "earth" the aerial when a storm gets very near, but a few distant rumblings won't set the house on fire! Another silly fad is that of saving obsolete apparatus, old transformers and bright emitter valves being carefully stored away in a "junk" box with the idea that they might come in useful. Throw them away—it is only a sign of meanness!

Finally, let me remind you of another fallacy—that of thinking you can get both concert-hall volume and plenty of

foreigners with the average three or four-valve set. Without doubt, by careful design of the L.F. side, with, say, push-pull amplification, you can obtain that "shake the floor" volume, but if you require range then you must have one or more H.F. stages. This leaves, at the most, one valve as L.F. amplifier, and that certainly will not make the loud-speaker jump off the table.

From this you will gather that it is not a fad to have two receivers in the house—one for foreigners and one for quality local-station reception. Quite a number of experienced technical people boast two such receivers, the local receiver being installed for use by the ordinary members of the household, and the range-getter being fitted up in the laboratory or workshop. A switch will enable the output from this latter receiver to be heard through the loud-speaker attached to the household



A slow-motion dial does not give more stations, but it may reduce your chances of missing them by 100 to 1.

set when a programme of sufficient interest is available. Where this idea is to be carried out, don't forget that a filter output is essential so that there will be no risk of interaction through the loud-speaker leads, and no voltage drop through the same cause.

**THE PHOTO-ELECTRIC CELL**

A GREAT interest aroused by the few windows which are the passer-

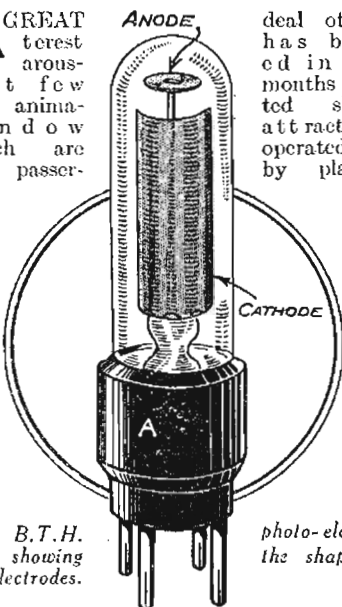

deal of interest has been seen in the months by the show-attactions, operated by placing

valve—and it contains two metal plates—a Cathode and an Anode. In the type illustrated, an ordinary valve-base is fitted, the Anode being joined to the Anode pin, and the Cathode to the valve pin. The glass envelope is not evacuated, but contains a gas. The peculiarity of this cell is that when a light is applied to the Cathode electrons are emitted, and if a positive potential is applied to the Anode (as in a wireless valve) these electrons are attracted to the Anode. The circuit shows how the P.E.7 may be arranged in the Grid circuit of a small L.F. or Power valve, so that the application of any light on the cell will operate the relay in the Anode circuit of the valve. If the cell connections are reversed the method of operation is also reversed, that is, a light shining on the cell will give a steady current in the Anode circuit of the valve, holding the relay closed and, on the light source being interrupted, the relay will open.

There are a great many uses to which this cell may be put, amongst which may be mentioned burglar alarms, switching on or off lights at predetermined times, or giving warning of the arrival of a customer in a shop. The enthusiastic amateur may devise many interesting experiments which will be made possible by the operating of a relay by means of light control.

One or two suggestions may perhaps be given before closing these notes. A 60-watt lamp is most suitable for this particular cell, and it

should be arranged, with the circuit shown, at a distance of 3ft. or so, and then gradually brought toward the cell. If before the lamp has been brought at the required distance from the cell the relay is operated, then it is necessary to reduce the cell potential. Alternatively, if the lamp has to be brought closer than 6in. before the relay is operated then the resistance across the grid circuit must be increased in value. Where it is desired to operate the relay with only a weak source of light, the grid-bias should be lowered until the anode current is brought just below that value required to operate the relay. A slight increase in current caused by a weak light on the cell will then be sufficient to work the relay. Where any special requirements are to be met, and any doubt is felt as to values of either applied potentials or resistance of relay, etc., the engineers of the B.T.H. Company will supply the necessary information.

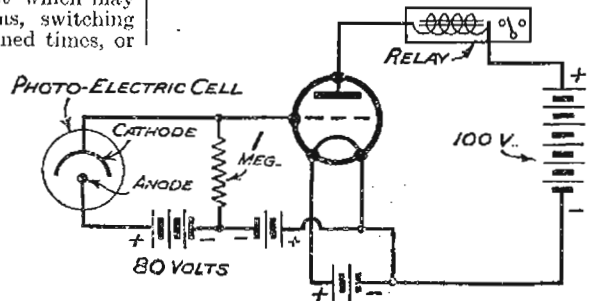

The standard method of connecting the photo-electric cell.

his hand over a small object on the window. It is quite amusing to hear some of the theories put forth as to "how it's done"—very few suggestions being anywhere near the mark. Actually, the little object which has made this type of advertisement possible is known as the "Photo-electric cell," one type of which is illustrated above. The cell consists of a small glass tube—very similar to a wireless



# COLVERN

## -T.D. COIL

**AN UP-TO-DATE COIL WITH  
UP-TO-DATE FEATURES**

TYPE T.D., an entirely new COLVERN COIL, designed to give super selectivity on both long and broadcast wavebands.

The coil is completely screened, giving a very neat appearance, and incorporates tapped aerial coupling and reaction, while the four alternative aerial tappings are arranged as sockets with a wander plug.

The first two tappings give aerial couplings similar to those normally employed, but with greatly increased selectivity.

Nos. 4 and 5 give a high degree of selectivity with weak aerial coupling—suitable for use in a "swamp" area.

A most important feature of this coil is that there is no break through on the long waveband from B.B.C. stations.

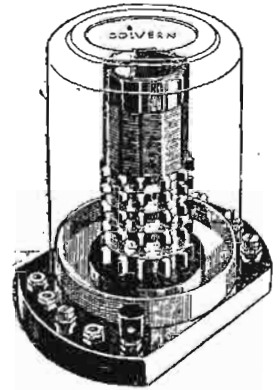

**TYPE T.D.**

PRICE

**8/6**

Wire-Wound.

For Voltage Regulation  
and Volume Control.

# VARIABLE COLVERSTATS

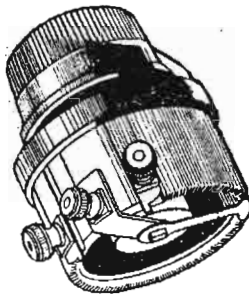

Type S.T.10. Rating  
10 watts. Standard  
values 500 to 50,000  
ohms. 5/6.

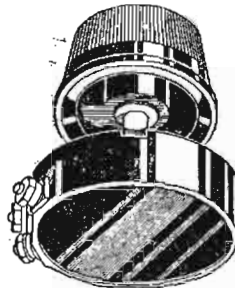

Type S.T.5C. Pro-  
tected Windings.  
Rating 5 watts.  
Standard values 250  
to 25,000 ohms. 5/3.

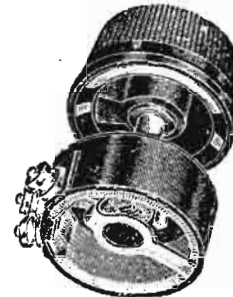

Type M.T. Rating  
3 watts. Standard  
values 25 to 10,000  
ohms. 4/6.

# STRIP RESISTANCES

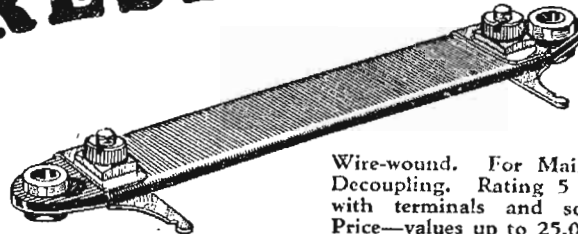

Wire-wound. For Mains Units and  
Decoupling. Rating 5 watts. Fitted  
with terminals and soldering tags.  
Price—values up to 25,000 ohms. 1/9.  
Price—values from 25,000 to 50,000  
ohms. 2/3.

Our 1933 Booklet Radio List No. 10 is now available and free on request.

# COLVERN LIMITED

MAWNEYS RD.,

ROMFORD, ESSEX.

# WHAT IS DISTORTION?

A Critical Survey of Causes and Suggestions for Remedies

By H. J. BARTON CHAPPLE,  
Wh. Sch., B.Sc. (Hons.), A.C.G.I.,  
D.I.C., A.M.I.E.E.

THE other evening I went by special invitation to a friend's house to help him instal a newly-built kit set from which he had great expectations. When everything was finally connected up and he switched on and tuned in one or two stations, he had to admit that something was wrong, for the reproduction was very poor indeed. In asking my advice, the conversation finally turned into a long explanation of what was really meant by the term distortion and how, unfortunately, it could so easily arise in a wireless receiver unless the proper precautions were taken.

Obviously, for perfect reproduction, the sound heard in the comfort of your own home from the loud-speaker should be an aural replica of what is taking place at the broadcasting studio of the station tuned in. When this fails to happen, as judged by a critical ear or by the movements of tell-tale meter needles inserted at correct positions in the power feeds, a reason should be sought, and the following notes may help readers in diagnosing the troubles.

### The H.F. Side

First of all it may come as a surprise to many to know that, contrary to popular belief, the high-frequency section of a wireless receiver is often the cause of more distortion than the low-frequency side. The introduction of so many high-powered broadcasting stations has made the question of selectivity rather an acute one. When a station is sending out speech or music it broadcasts, in addition to the carrier-wave, other frequencies which are known as side-

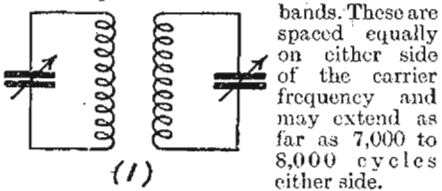

A receiver of the ordinary type boasting of razor-edge selectivity cuts off a large section of these side-bands, or at least reduces their amplification to such an extent that they compare very unfavourably with the amount of amplification accorded to the lower frequencies. Anyone musically inclined will realise that the higher frequencies bring about the brilliance or timbre, and if they are not present then quality must to a certain extent be reduced.

### Band-Pass Tuning

If the constructor of a wireless receiver finds himself in a cleft stick, owing to his desire for adequate selectivity without cutting side-bands, he can adopt what has come to be known as band-pass tuning. In effect this method is a modified version of the device greatly used in the very early days of broadcasting, when selectivity was obtained by employing two tuned circuits, with variable magnetic coupling between them, usually by means of swinging coil holders.

In the modern arrangement we have three main types, and these are shown simply in Figs. 1 to 3. In every case it will be noticed that there are two tuned circuits, and energy is transferred from one circuit to the other by a mutual magnetic interaction (1), a coil common to both tuned

circuits (2), or a controlled capacity-coupling (3). The frequency response of each circuit is, and it is possible to make the complete frequency range and reject the other words, and re-maintained with select-



carefully con-  
coupling (3).  
cy response of  
thus combined,  
sible to make  
circuit accept  
over quite a wide  
almost-whol-  
others. In  
brilliance  
duction is  
together  
ivity.

### Faulty Components

Another very marked cause of distortion is the use of "shoddy" components of doubtful origin. "Penny wise and pound foolish" is an old adage, but it strikes a very true note where wireless is concerned, so do not be tempted. It is better to economise on the total number of intervalve coupling stages and expend the money saved on good quality components.

Keeping for the moment on the question of false economy, there is one item amongst a wireless set's accessories which is so often neglected, and that is the high-tension battery. Except for sets with a very small anode current consumption, do not use those of small capacity because they are cheaper. H.T. battery renewal is a problem which has got to be faced, and it is a step in the right direction towards the cure of distortion if batteries are chosen of high capacity and ample voltage.

The initial expenditure admittedly is proportionately high, but they stand up to the current demands without a rapid drop in voltage, and their life, of course, is much greater than those of their smaller brothers. Too often is a set blamed for distortion when all the time the fault is located in the fact that it is being starved of its H.T.

### Valve Couplings

Returning now to our question of frequency distortion, the items chiefly responsible for this are the methods of couplings between the valves and the loud-speaker itself. Taking the first named it must be remembered that if L.F. transformers are employed, the primary or input winding must have an adequate primary inductance. This does not necessarily mean that the transformer with the largest size is going to give the best results. Modern development has produced transformer cores which are quite small compared to the early types. It is also necessary to maintain the inductance high even when quite large anode currents from the valve pass through the primary winding, so in this case it is necessary to learn whether a manufacturer guarantees the inductance

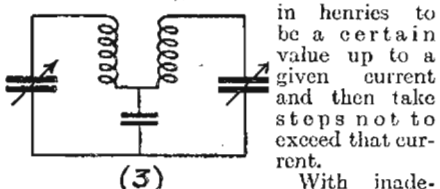

in henries to be a certain value up to a given current and then take steps not to exceed that current. With inade-

quate primary inductance in transformers, there will be a loss of the bass frequencies, so that even if you have the most perfect sound-reproducer coupled to the set, if the bass frequencies are lost in the set, they will not be heard from the loud-speaker.

### Resistance Capacity

If now we turn to resistance-capacity coupling the secret of success here lies primarily in the selection of suitable valves and components. For most purposes the value of the anode resistance should not exceed about four to five times the valve impedance. The grid leak on the other hand may be about five times the value of the anode resistance, while the capacity value of the coupling condenser depends primarily on the value of the lowest frequency to be amplified, the ohmic value of the grid leak and the fraction of maximum amplification desired at the lowest frequency. The greater this last-named fraction the greater will be the capacity of the condenser.

For example, if the grid leak is half a megohm, the lowest frequency 50, and the fraction just mentioned  $\frac{1}{2}$ , then the capacity is calculated to be about .015 mfd., so be careful not to make your condenser of low value if you want to pass through the low frequencies.

Passing now from frequency distortion, which, as has been pointed out, arises from the exaggeration or, alternatively, the suppression of particular notes, frequencies or bands of frequencies, we come to what is known as amplitude distortion. This produces a mutilation of the wave form of the original sound and the incorrect use of valves is one of the principal causes.

### A Question of Bias

It may be that the valve is over-biased or overloaded, or even under-biased. To secure a faithful replica of the signals handed on to the grid of the valve, the incoming grid-swing must take place over the straight portion of the valve's characteristic.

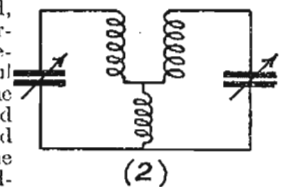

If by chance the valve is over-biased, the incoming signals will operate over the lower curved part of the characteristic, and distortion will occur. If a valve is overloaded, that is to say, has a grid swing applied to it greater than it can handle on the linear portion of its characteristic, then distortion is most marked—one gets frequently what is known as blasting.

As the signal is amplified stage by stage, the grid swing increases in magnitude, and each valve following a particular stage must be capable of accepting what is passed on. A good indication of the strength of signal which a valve can handle without distortion is afforded by the value of grid bias recommended by the maker. For example, a valve of the H.L. class requiring a grid bias of about 3 volts might be used for the first stage, while a valve requiring 7 or 8 volts grid bias might follow it.

Now, although these published figures

(Continued on page 62).

# "GIVING THE FIRST CLASS SERVICE WHICH WAS EXPECTED OF THEM"

" . . . Radio enthusiasts can purchase them with every confidence. Their outputs are above the average and they give a clean, steady output . . . "

*says the Technical Editor of "Popular Wireless"*

You can end all your H.T. battery troubles—you can take all the uncertainty out of battery buying, for Ediswan H.T. Batteries are now GUARANTEED against failure to give absolutely satisfactory service. No battery manufacturer could afford to give such a guarantee unless he had complete confidence in his product. Every single cell in every Ediswan battery must successfully pass four separate tests before it leaves the factory, and special precautions are taken to ensure perfect insulation between cells.

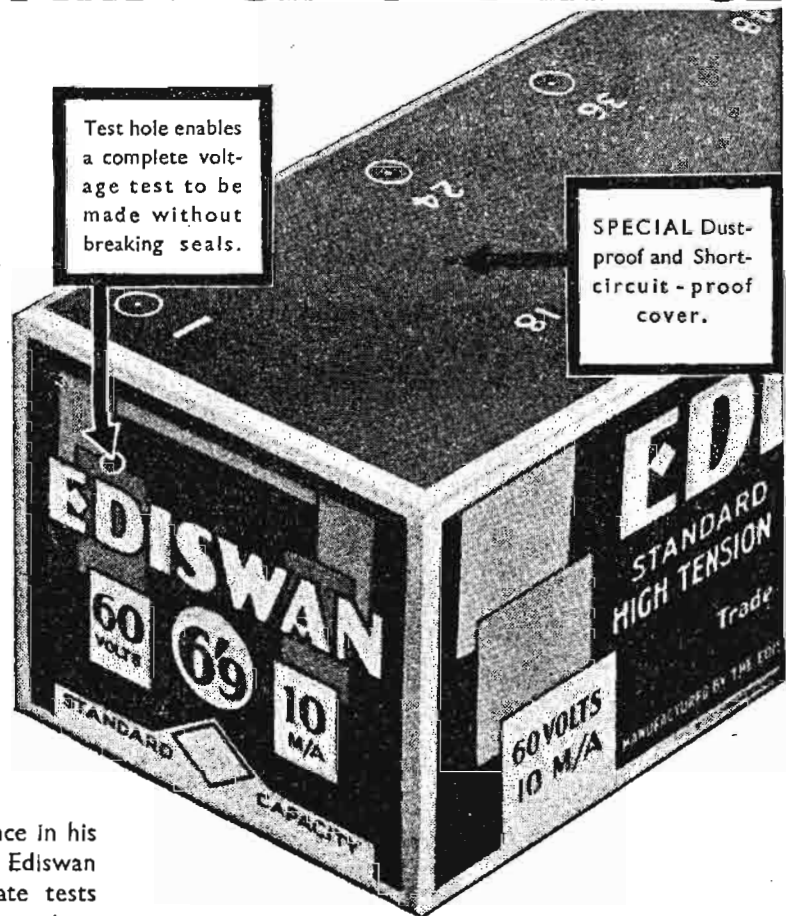

**Standard Capacity.** Where the anode current required does not exceed 10 M/a these batteries will give highly satisfactory service. If super-power valves are used, the super-capacity type should be used.

**Super Capacity.** These batteries have twice the capacity of the standard type, and, owing to their large reserve of power, last nearly three times as long when used as a replacement to a battery of standard capacity.

Look for the **Ediswan Authorised Dealer** sign when you buy!

Send for your **FREE** copy of "How to get the most out of your H.T. Battery." Full of useful data, hints and tips.

## Guarantee

The Edison Swan Electric Co. Ltd. guarantee that Ediswan Batteries are of full voltage and capacity. Should any Ediswan Battery fail to give satisfactory service, we undertake to deal with customer's complaint within 24 hours of receipt of the defective battery.

# EDISWAN

*the Guaranteed*  
RADIO H.T. BATTERIES





## LOGARITHMIC VOLUME CONTROL

The IGRANIC Logarithmic Volume Control is wire wound and fitted with a specially graded resistance track. It has been evolved to afford a uniform control of volume where a valve or valves of the Variable Mu type are employed in a circuit. The graded resistance makes the volume control obey the same law as the valve. Sizes: 5,000, 10,000, 50,000 ohms, and they can also be supplied with combined switch. Price 5/6 (with switch 7/6).

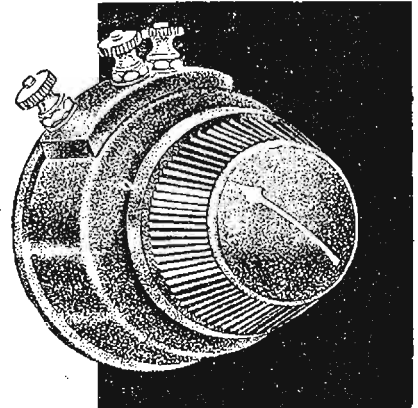

**IGRANIC**  
**COMPONENTS WILL**  
**BE THE MAKING**  
**OF YOUR SET.**

### IGRANIC ANTI-CAPACITY SWITCH

For use in all circuits where self capacity in a switch must be reduced to a minimum. Excellent springs ensure positive contact. Well spaced soldering tags. Semi-rotary movement. One hole fixing.  
 2 way Change-over switch 1/9  
 3 " " " 2/-  
 4 " " " 2/6

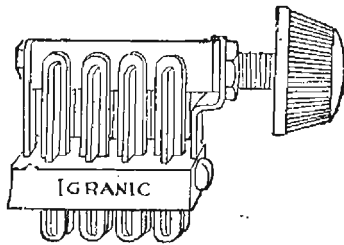

Write for Catalogue J.1198 to  
 IGRANIC ELECTRIC CO., LTD., 149, Queen Victoria Street, London, E.C.4.

### SPECIFIED FOR THE "DOLPHIN THREE"

The IGRANIC DIFFERENTIAL CONDENSER has a perfectly balanced maximum capacity of .00015 mfd. on each side, and is an extremely dependable component with a very low minimum capacity. Soldering tags are fitted. Price, complete with bakelite knob, 3/6.

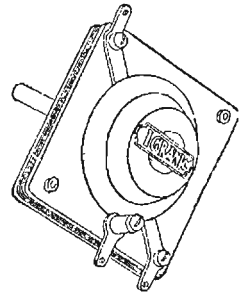

### IGRANIC MIDGET RADIO SWITCH

A neat, compact component specially suitable for switching filament current "on" and "off." Moulded bakelite with heavily plated metal front—one hole fixing. 1 amp at 250 volts. 3 amps at 125 volts. Prices, with terminals, 1s. 8d., with soldering tags, 1s. 6d.

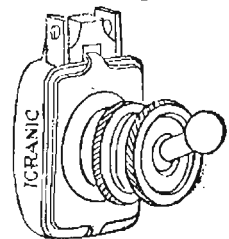

### IGRANIC PUSH-PULL SWITCH

Smooth action and positive contacts. Terminals and soldering tags on ebonite strip. All metal parts nickel plated, reducing resistance to a minimum. One hole fixing. Price 9d.

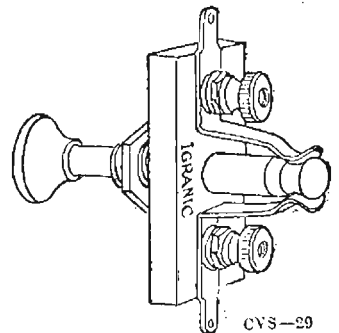



# IS YOUR SET OFF COLOUR?

If you ask the average listener, "How's the wireless going?" how often do you get the reply, "Oh, not too badly, but it doesn't seem quite so good as it used to be"? In other words, how often do you find a set which has been in use, say a year, functioning as well as when new? Very rarely, I suggest. And the reason is not simply because the valves are not new or because the H.T. battery is running low. Admittedly, these are amongst the most obvious causes, but, on the other hand, the valves and batteries may have just been renewed or a mains unit may take the place of the latter and still the set is not so loud or clear as

IN THIS ARTICLE A MEMBER OF OUR TECHNICAL STAFF GIVES SOME OF THE REASONS WHY YOUR RECEPTION MAY GRADUALLY FALL BELOW STANDARD AFTER YOUR RECEIVER HAS BEEN IN USE FOR SOME TIME, AND TELLS HOW YOU MAY RESTORE ITS LOST "TUNE."

have seen old batteries used in conjunction with a new one with the idea of boosting the voltage. This practice cannot be too strongly condemned!

### The Cure

If your set is not giving of its best it may be due to one of the foregoing causes or to dirty or faulty contacts, and a complete cure can usually be effected by giving it a little tuning-up.

First of all, disconnect all leads, at the same time noting where each was joined, unless they are all marked, and then take the set out of the cabinet. Dust it thoroughly, taking particular care to clean between all the terminals, especially those which are close together (see Figs. 1 and 2). The best way to remove dust from the vanes of the variable condensers is to blow it out with a bicycle pump or with a pair of bellows.

Having completed the dusting it is just as well before proceeding further to dry the whole thing in front of the fire or to stand it in a warm gas oven after the gas has been extinguished. Do not allow it to get hot, as excessive heat will warp ebonite and melt the wax used in fixed condensers. If the gas oven is used it is best to leave the door on the jar to avoid condensation, which, needless to add, would have disastrous effects.

### Go Over All Connections

Before returning the chassis to its case inspect all the connections, seeing that all

being enclosed, appear to be weatherproof. That they are not necessarily so I had very strikingly brought home to me a short while ago. I was asked to examine a set which the owner said was working very poorly, although he had done everything possible to keep it in good order. The batteries, he informed me, were well up, and the aerial and earth connections in good order. Then I switched on. The set certainly sounded very wheezy, so I looked inside. It was full of dust, and smelt rather musty. It was then that I noticed the state of the aerial coil. It was of cotton-covered wire on a cardboard former, and was actually covered in *mildew*!! This was, of course, an extreme case, and yet the set had not been left open. It had merely been standing for a couple of years right under a window, and the dust and damp had somehow found its way through the hinges of the lid and back.

### A Surprising Fact!

It is really astounding how dust will accumulate in a set which has apparently a close-fitting door to the case. There are, I know, quite a number of commercial sets which are genuinely dust-proof, but if your set is home made, or of the kit type, or has to be opened frequently for adjustments, it is almost certain to get dusty. The reason that dust is injurious is because it forms a partial conductor. Dry dust does not conduct very readily, but it is usually associated with atmospheric moisture which gives it definite conducting properties. Thus a layer of damp dust over your set has much the same effect as would an infinite number of high-resistance grid leaks joined between all the various terminals. Each grid leak sneaks a fraction of your set's power!

While on the subject of dust and damp from without, let me mention that in the case of battery sets and portables, dampness may also come from within. Spray from the accumulator is well known, but how many people realize that the H.T. battery is only dry in name? As a matter of fact, it wouldn't work if it were dry; therefore it should always be scrapped before it gets to the stage where the zinc cells inside are eaten through and the salts ooze out and moisten the cardboard container. Fortunately, this state does not usually set in until the voltage has dropped below a working figure, and the battery is discarded on that account, although I

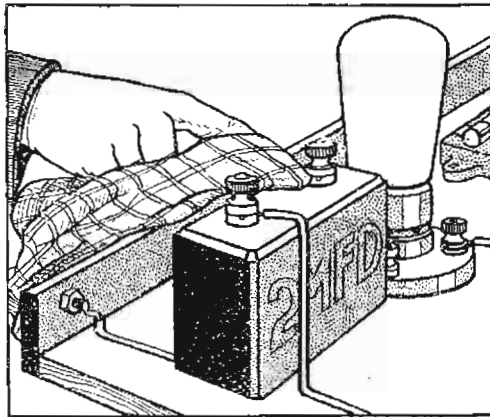

Fig. 1.—In dusting, particular care should be taken to clean between the various terminals.

at first! Where then shall we look for the cause of this subtle falling-off in quality and power? Well, there are three causes which contribute more than anything else toward poor reception of this sort. They are DUST, DAMP, AND DIRTY CONTACTS!

### The Effects of Dust and Damp

In the early days of radio, when sets looked horribly "scientific" and bristled

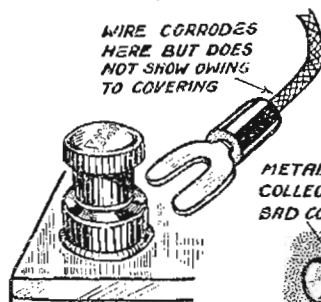
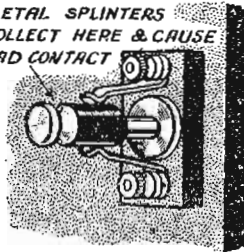

Fig. 4.—A frequent cause of poor reception is dirty filament switch contacts.

Fig. 5.—Why you should re-make terminal connections. Corrosion due to acid-creeping extends up the wire under the insulation.



with exposed valves, coils, crystal detectors, and terminals, etc., we were taught that dust and damp were the chief enemies of good reception, and accordingly always kept a duster handy. Nowadays, however, this fact is hardly mentioned, with the result that sets are often placed near the window to receive all the dust and rain that happens to blow in. I think this is partly because most modern sets, owing to their

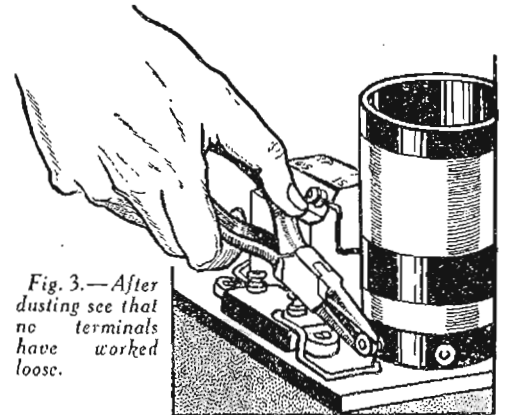

Fig. 3.—After dusting see that no terminals have worked loose.

the terminals are screwed down tightly (a twist with a pair of pliers will do) and examine the contacts of the switches (see Figs. 3 and 4). The filament switch is

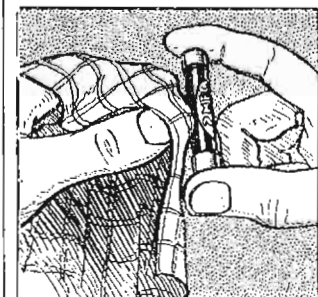

Fig. 2.—To dust the grid leak remove it from the clips. Also dust between the clips before replacing it.

often a source of trouble, as after constant use little splinters of metal rub off the electrodes and cause bad contact. The symptoms are crackling when

(Continued on next page)

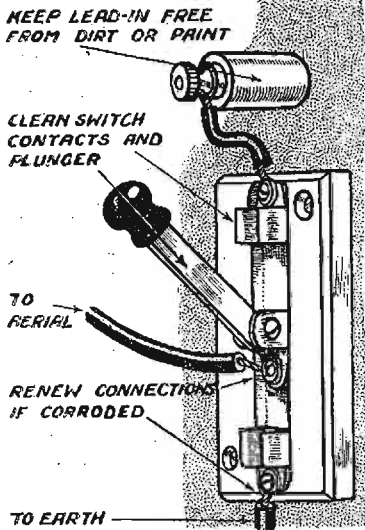

Fig. 6.—A typical lead-in system with earthing switch, showing points needing occasional attention.

you switch on or when you touch the switch, and sometimes you have to switch off and on again before you get proper reception. Cleaning the switch carefully with a non-fluffy rag will make all the difference. In the case of a mains-operated set you may also be using a standard tumbler switch of the same type as the house lighting switches for switching on the mains. These are not always above reproach, and it will pay to see that the contacts are clean and springy. Switch off

at the meter before touching this switch, however.

**Cleaning Spade Terminals**

The receiver should now be replaced in the cabinet and reconnected. It is best to remove wander plugs and spade terminals from the aerial and battery leads, and refit them. This particularly applies to the L.T. leads where an accumulator is used, as although it is not noticeable until the covering is removed, the wires often corrode just where they join the terminal owing to the action of creeping acid and acid fumes (see Fig. 5).

**Don't Forget the Aerial and Earth**

Finally, let me say just a word or two about the aerial and earth system. If they have been in use for any length of time, the leads should be examined, and all connection to both lead-in and lightning switch re-made. Fig. 6 shows the points needing attention. The wire usually becomes very brittle at these points, and if you have enough wire to spare it is best to cut off the old ends and re-scrape the strands and join up again. If necessary, re-make the joint between the earth wire and the earth tube or whatever connection you have (see Fig. 7). The porcelain insulation of the aerial lead-in tube should also be wiped over with a cloth. See also that

**DIRTY BINDING SCREW**

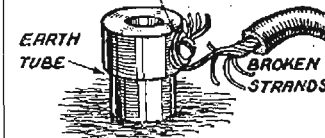

Fig. 7.—Some likely causes of a poor earth.

comes very brittle at these points, and if you have enough wire to spare it is best to cut off the old ends and re-scrape the strands and join up again. If necessary, re-make the joint between the earth wire and the earth tube or whatever connection you have (see Fig. 7). The porcelain insulation of the aerial lead-in tube should also be wiped over with a cloth. See also that

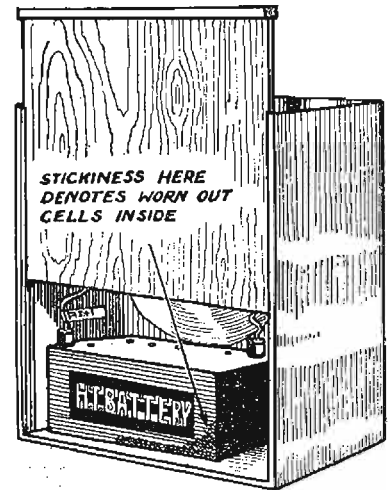

Fig. 8.—Stickiness on the outside of the H.T. battery means deterioration and will cause harm if left in your set in such condition.

it has not been painted over, as may happen if the house has been redecorated. Painters seem to delight in daubing insulators! Now lower your aerial, clean the insulators, and haul it up again. If you pull it tight it will probably be several feet higher in the middle than previously. This is one of the many little things which, taken together, will bring your reception back to its pristine brilliance. Having finished, you will now be able to sit down and listen to a set which has regained its lost youth!

# USING A PENTODE

When using a pentode valve a tone control is a valuable refinement.

**M**OST amateur-made sets are not fitted with a tone control, and the addition is well worth while. A tone control is most desirable when a pentode is employed in the output stage, because this type of valve tends to emphasise the high notes, so making reproduction rather "screechy." The two systems shown in A & B, however, are equally applicable to either pentode or ordinary three electrode valves, and although indirectly-heated valves are illustrated the same connections apply equally well to battery-fed ones.

Diagram "A" shows a 50,000-ohm variable resistance and .01 mfd. condenser connected in series across the primary winding of the output transformer. Decreasing the circuit resistance gives a gradual "cut-off" to the higher frequencies, so making the lower notes more prominent. The resistance and condenser are equally effective, whether connected across the primary winding of an output transformer, across an output choke, or across the terminals of a directly-fed speaker. Diagram "B" illustrates a less common form of tone control and applies when the

By "PENTAMP"

speaker is connected on the choke-capacity principle. With this form of coupling it is usual to employ a fixed condenser of about 1 mfd., but experiment shows that low-note reproduction is often improved by reducing the capacity of the condenser to about

.25 mfd. Good tone control can therefore be obtained by using, say, three condensers of .1 mfd., .15 mfd. and .25 mfd. and so arranging them that they may all be connected in parallel, or that one, or two, can be used separately. The connections will be as follows: connect one terminal of each condenser to the plate of the output valve and take each of the other terminals to those of a rotary switch of which the slider is joined to the loud-speaker. The switch should be wired so that capacities of .1 mfd., .25 mfd. or .5 mfd. can be obtained by using the first condenser by itself, putting the first two in parallel or by connecting all three in parallel.

In addition to the above schemes, special types of pentode output transformers and chokes are obtainable. These enable the impedance of the valve to be correctly matched.

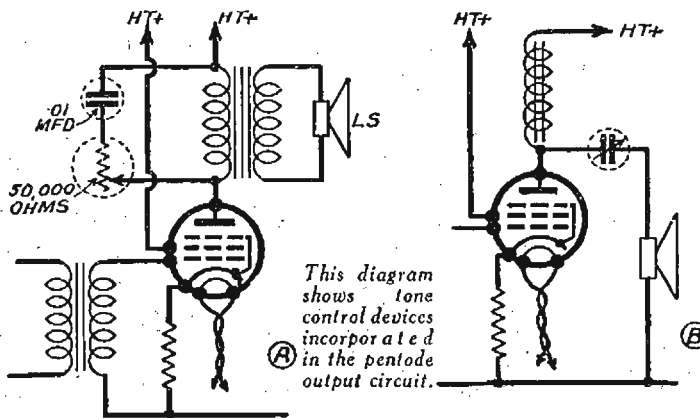

Order Next Week's Copy NOW— And Make Sure of Your FREE GIFT BOOK

**OLYMPIA**

**... Proved  
ORMOND  
Value & Quality  
Greatest of all!**

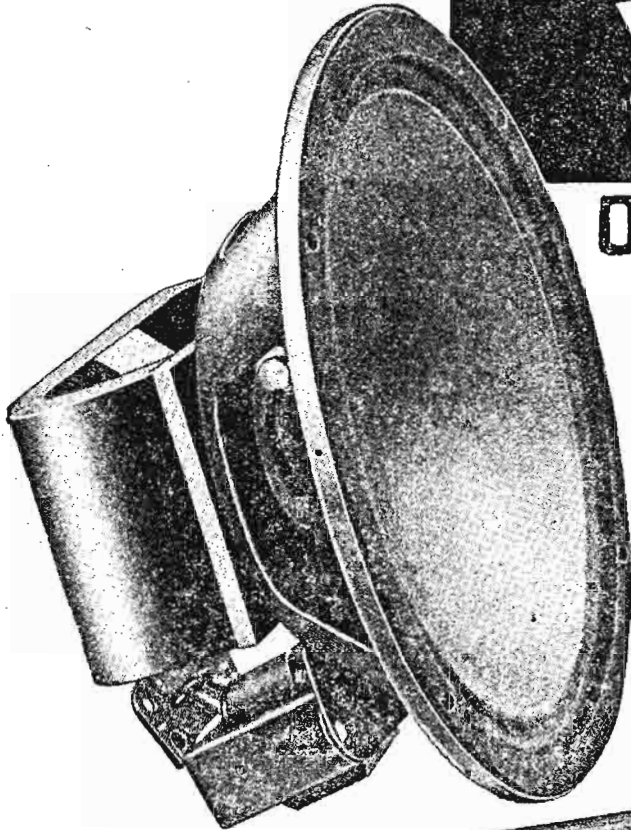

**ORMOND Permanent Magnet  
M.C. LOUDSPEAKER**

One of the most popular exhibits at Olympia was this speaker, which offers reproduction of the best, at a price within the reach of all. Its performance is admirable, excellent response being obtained throughout the frequency range. Its construction is robust, the fitting of a large cobalt Permanent Magnet ensuring long life and reliability. Complete with Input Transformer, it measures 8ins. in diameter by 4½ins. in depth. Cat. No. R/475.

**38/6**

**FOR PUNCH POWER & PURITY**

**ORMOND M.C. CABINET  
LOUDSPEAKER**

This Ormond exhibit also provoked widespread interest at the exhibition. It incorporates the chassis described above, in a figured Oak cabinet of handsome appearance and acoustically correct design. It is supplied complete with Input Transformer and provided with terminals for connections. Size 14ins. x 14ins. x 8½ins. Cat. No. R/477.

**59/6**

This speaker may also be obtained incorporating the Electro Magnet Moving Coil Unit. Price 51s. Cat. No. R/476.

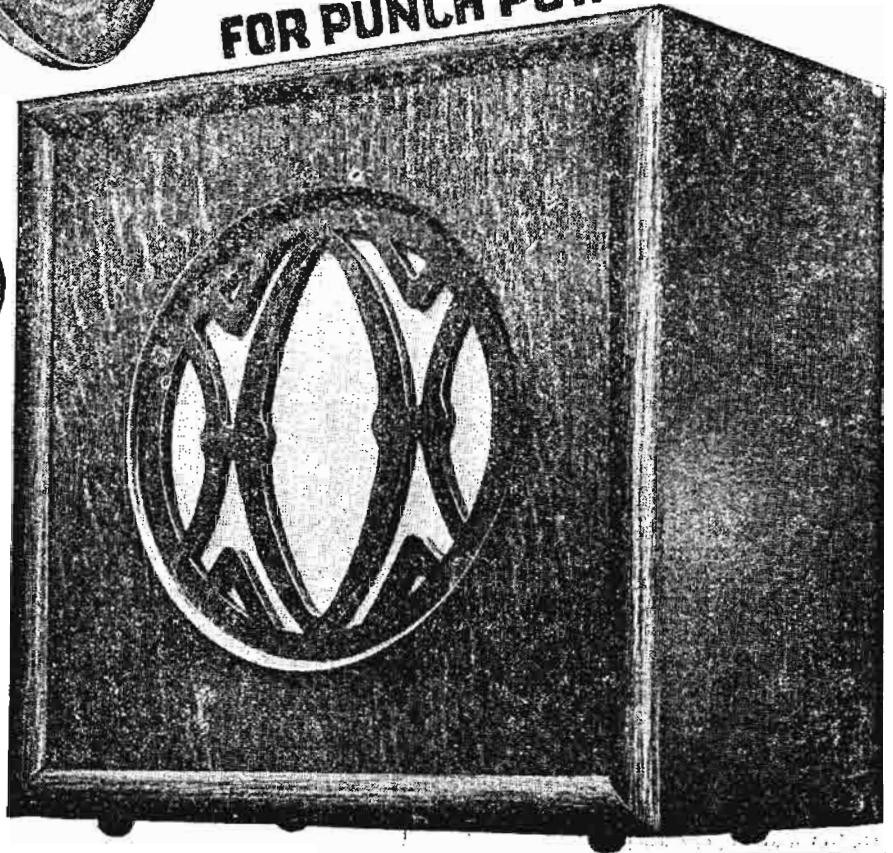

**THE ORMOND ENGINEERING COMPANY, LTD.**  
Ormond House, Rosebery Avenue, London, E.C.1  
Phone: Clerkenwell 6334-0-0 and 9341-5-6.  
Grams: Ormondengi, Illing.

# FAULTY CONNECTIONS: AND HOW TO AVOID THEM

**M**ANY a well-constructed set is handicapped in its performance by faulty connections. There is really no excuse for this, because it takes no longer to wire a set correctly than it does to make the connections in a haphazard manner. In the first place, there is the question of what sort of wire to use. Some constructors still favour the stiff self-supporting bare-tinned copper wire, which certainly is

In this article A. J. BUDD explains how faulty connections are often responsible for poor reception, and gives sound advice on how to wire a set correctly.

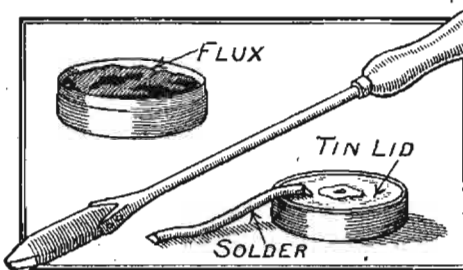

Fig. 1.—A small tin lid is very handy for holding the solder.

neat and easily traced out when checking a circuit. In modern sets, however, about the best connecting wire to use is No. 18 gauge tinned copper wire covered with an insulating sleeving. Differently-coloured sleeving can be used for different parts of the circuit to facilitate checking and testing. Most radio components have terminals for those who cannot do soldering work, but whenever possible a soldered joint should be made in preference to clamping a wire under a terminal nut.

## Soldered Joints.

The soldering of wireless connections is quite a simple matter if a few simple rules are borne in mind. The materials required are a soldering iron, or "copper bit," a stick of solder, and a small tin of flux. Don't make the mistake of thinking that a very small soldering bit is best. Get a good-sized bit, at least  $\frac{3}{16}$  in. diameter and 2 in. long. Always heat the soldering bit in a clean flame, such as that given by a gas ring, and well "tin" the nose of the bit before using it. To do this, well heat the bit, quickly clean the end with an old file, dip it in the flux, and press it on a piece of solder till the latter melts. Turn the bit till the solder adheres all round the end. A small tin lid is very handy for holding the solder, as shown in Fig. 1. Next, well clean the ends of the terminals to be soldered, apply a touch of flux with a match-stick, and a spot of solder with a hot bit. Dip the end of the connecting wire in the flux, hold it in place on the terminal stem, and apply the hot bit for a few seconds till the joint is made.

Instead of just soldering the straight end of a wire to a terminal stem (A, Fig. 3) which is a common practice, it is much better to bend the end of the wire into a loop (B) of a diameter a little less than that of the stem, over which it can be forced by the soldering iron. This joint is strong and quite simple to make. Each joint should afterwards be rubbed over with a piece of rag to remove all traces of flux.

## Making Connections Without Soldering.

Where it is desired to make the connections without soldering it should be remembered that there is a right and a wrong way of forming the loop at the wire for clamping under a terminal nut. The proper way is to bend the loop in a clock-wise direction, as shown at C, Fig. 3, so that when the nut is tightened the wire will tend to wrap itself more closely around the stem. When the loop is placed over the terminal the opposite way round it will tend to open out. This point is important when the terminals are of small size, like those on a valve holder.

In connecting two or three wires to a single terminal, a dependable job can seldom be made by bending each wire into a separate loop and fitting them one on top of the other over the terminal stem.

A much better plan is to solder a small tag to the end of each wire, or, if only two wires are to be connected, they can be soldered to a single

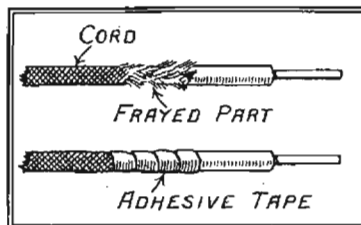

Fig. 2.—Connecting cords sometimes become frayed near the ends, and it is a good plan to neatly bind the affected parts with adhesive tape.

tag. When connecting the end of fine wire, such as that from a tuning coil, to a common terminal, it is a good plan to twist the wires together before bending them, to form a loop.

## Important Details.

To obtain the best results from a set particular care should be taken with the grid and anode connections, which should be as short and clear from adjacent wires as possible. To this end it is well to wire the grid and anode circuits first, and then to arrange the other wiring in the next most convenient manner.

Anode and grid connecting wires should be kept well away from metal screens and the metal end-plates of variable condensers. Where the wire from the plate of a screened-grid valve passes through the metal screen, capacity losses may be minimised by drilling a hole of about  $\frac{1}{16}$  in. diameter in the screen and pushing in a rubber accumulator vent plug. The connecting wire, which can then be threaded through the central hole in the plug, as shown in Fig. 4, will be rigidly located in the centre of the hole

in the screen, and will have the advantage of the additional insulation provided by the rubber plug.

## Look to Your Connecting Cords.

Untidy flex leads are not only unsightly, they also cause trouble—sometimes serious. This is especially true where mains apparatus is used, and in such cases the flex leads, particularly the ends, should be regularly overhauled, and kept tidy. A wrapping of adhesive tape, or the fitting of spade ends or eyelet-tags, is a good plan, and will prevent a good deal of the crackling noises which the untidy leads are likely to set up.

It sometimes happens that one or two strands of wire in a loud-speaker cord become fractured. This will set up mysterious noises when the set is working, and the best remedy is to fit a new cord. Where part of a cord has become frayed, but is otherwise in good condition, the frayed part should be bound with adhesive tape, as shown in Fig. 2. If the covering is allowed to wear away, a short circuit is likely to result. Danger points are where cords pass through holes in any part of the set, particularly the metal chassis or screen.

An all-mains receiver or one employing an eliminator, has a cord to connect up to the supply main, and after a time this cord may show signs of wear. Usually the fault occurs at one of the ends, and it is as well to examine the cord occasionally for any signs of wear because a short circuit here is likely to prove expensive, if not dangerous.

## Loud-Speaker Connections.

It is not an uncommon thing for a loud-speaker to be connected up wrongly. Some loud-speakers have incorporated some form of filter or transformer, but most of the more inexpensive units are designed to be connected up direct. They should, however, be connected up in a certain way, the reason being that unless a filter arrangement is used, the loud-speaker windings

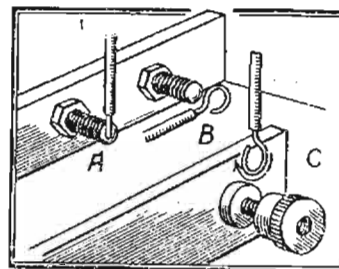

Fig. 3.—Instead of soldering the straight end of a wire to a terminal stem, it is much better to bend the end of the wire into a loop and then solder it.

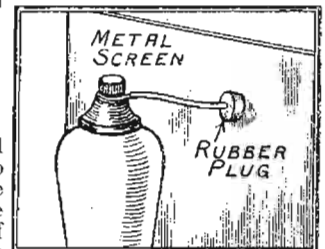

Fig. 4.—Where the wire from the plate of a screen grid valve passes through a metal screen, capacity losses may be minimised by adopting the idea shown here.

are called upon to carry the full anode current of the power valve. If the current is not flowing in the right direction through the coils, it will tend to weaken the magnets. If your speaker terminals are marked "positive" and "negative," correct connection is easily done. If, however, the markings have got rubbed off, you can determine which

(Continued on page 60)



# "OUR BEST WISHES"—

We have received dozens of messages from prominent members of the Radio Trade conveying good wishes for the welfare of PRACTICAL WIRELESS; a random selection is published below. Others will appear next week.

From D. P. Wheeldon (General Manager, Six-Sixty Radio Co., Ltd.).



"Your intention to supply a highly useful service to amateur constructors will, in our opinion, meet with very keen interest, and we are sure there is ample scope for a journal with your excellent aims. Having ourselves made so prominent a feature of helpful service to all valve users, we are glad to offer you our heartiest good wishes."

*D. P. Wheeldon*

From J. G. Wright (Director, Wright and Weaire Ltd.).

"We, as probably the oldest-established firm of wireless component makers in the industry, send you greetings, and welcome the advent of a new force that, we hope, will make a deep impression upon the amateur set-builders throughout the length and breadth of Great Britain. We commend your policy and are quite sure such a policy, steadfastly maintained and vigorously pursued, will have far-reaching effects upon the industry. It is an axiom: 'There is always room at the top,' and we are sure, under the policy you intend to commence with, you will not only reach the same but remain there in an unchallenged position. We trust that in launching out on your new venture you will make many friends who will support you through the coming years."



Mr. A. R. Rothschild, Sales Manager, of Messrs. Wright & Weaire.

*J. G. Wright*

From E. M. Lee, B.Sc. (Belling and Lee, Ltd.).

"With the ever-growing army of amateur constructors we are in close touch, for the simple reason that we are one of the largest manufacturers of radio connections in Great Britain. We are certain that your new publication, dealing in simple language with the practical side of wireless, fills a real need, and we wish you all success in your new venture."



*E. M. Lee*

From L. B. Felton (Joint Managing Director, Lectro Linx Ltd.).

"I should like to take the opportunity of wishing you every success on the occasion of the first issue of PRACTICAL WIRELESS."

"Everyone has read about the tremendous interest displayed by the public at the recent Radiolympia, and from my own experience I am satisfied that the amateur experimenter is still on the increase. From your policy it is clear that PRACTICAL WIRELESS will be run on the soundest lines, and I am sure the public will welcome your new venture."

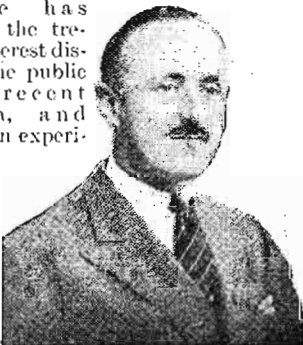

*L. B. Felton*

From W. F. Taylor (Telegraph Condenser Co., Ltd.).

"On behalf of my company. I should like to take this opportunity of welcoming you into the popular wireless field with your new paper, PRACTICAL WIRELESS. We feel sure that any publication which has the backing of Messrs. George Newnes, Ltd., and the technical experience of your good self, is bound to be a boon to every amateur constructor."

"We particularly welcome your scheme for solus specifications of any particular make of components. The present arrangement followed by some of the set designers of specifying a dozen different makes for any one particular component leaves a lot to be desired. The different characteristics of different components very often make it essential that the type used by the designer should be duplicated by the constructor. We are following up this opinion with advertising support, which in itself is indicative of our feelings."



From Lt.-Col. G. D. Ozanne, M.C., M.I.E.E.

"I welcome the appearance of PRACTICAL WIRELESS as a paper which will do much to foster love of radio constructing among the younger generation, and will undoubtedly contribute to the maintenance of



that radio-minded spirit which is responsible for the premier position held by British Radio in the world to-day. I wish the enterprise every success."

*G. D. Ozanne*

From W. Scott Worthington (Managing Director, Peto Scott Co., Ltd.).

"It is with great interest and appreciation that I welcome and recommend PRACTICAL WIRELESS to new readers. I say with interest, because the practice of building sets by home constructors is growing every day. It is with appreciation that I recommend your policy of specifying one make of component only when giving the list of components used in building the set you feature in your constructional articles. During my thirteen years' experience in supplying the needs of the home constructor (and may I remind you here that I was the pioneer of the Radio Kit business) I have had ample opportunities of proving my assertion that if an author claims certain performances for the set he is describing, the amateur constructor must build a faithful reproduction of the author's original if he is to obtain results which duplicate the author's. Hence my firm's Pilot Author Kit policy."



"I feel sure, sir, that your publication will infuse a new enthusiasm into those discriminating constructors who decide to subscribe to your welcome contribution to the evergrowing multitude of home radio constructors. Every wish for a successful first number, and a long life."

From R. H. Nunn (Managing Director, Messrs. Regentone Ltd.).

"As manufacturers of main units, some of which are specially designed for use by the home constructor, we congratulate you on your first issue, and we shall watch your future activities with interest. There is no doubt that a magazine of the type of PRACTICAL WIRELESS will be of great practical value to the radio public."



*R. H. Nunn*

# MY FAVOURITE CIRCUIT—

## Some Famous Set Designers Discuss the Advantages of Their Pet Circuits



Mr. Frank Preston.

From Frank Preston, F.R.A.

As an experimenter and designer of receivers, I find it rather difficult to pick out any one circuit arrangement as being my favourite. Perhaps I should explain that I am in the very happy position of having numerous sets in my laboratory,

and it is usually fairly easy, therefore, to select one specially suited to any particular purpose.

Despite the undoubted popularity of screened-grid high-frequency amplification, my choice lies with the older and well-known Det. 2 L.F. type of circuit. No doubt I shall be hailed as old-fashioned, but I would point out that I speak from experience of every kind of set. Although the sequence of valve stages is an old-fashioned one, my favourite circuit includes a number of quite up-to-the-minute features, such as adjustable tone-control, resistance-fed L.F. coupling, and a highly selective tuning circuit.

All these features are illustrated in the accompanying diagram. The aerial is connected to an untuned winding through a pre-set condenser, this winding being very loosely coupled to the tuned grid winding to which reaction is applied. Due to the very weak aerial coupling and accurate reaction control, tuning is extremely sharp;

trated for simplicity, but the circuit is equally well suited for use with A.C. valves.

From W. J. Delaney

My favourite circuit is, of course, the one which I employ in my home receiver, and, being a musician, I must have a receiver which gives adequate volume with a degree of quality which is above reproach. The circuit consists of three stages only—S.G., detector, and out-

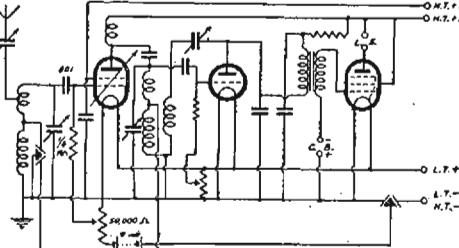

Mr. W. B. Richardson's favourite circuit.

put stage. The detector valve works on the power grid principle, and to ensure the maximum anode potential a 300 henry iron-cored choke is included in the anode circuit. To supply the detector with an adequate signal, an efficient H.F. stage precedes it,

is fed from this stage by means of a tapped push-pull output choke in place of the more customary output transformer. For gramophone record reproduction, a pick-up is included in the grid circuit of the detector valve, and to enable the same quality standard to be obtained from records the output from the pick-up is compensated by a McLachlan Compensator. The circuit shown probably looks rather formidable, but the results, in my opinion, justify the arrangement.



Mr. W. B. Richardson.

From W. B. Richardson

LOCAL conditions and an inherent instinct to get value for money are, I think, the chief reasons why I favour the S.G., det., pentode circuit. When properly designed it will give all one ordinarily requires in the way of station getting and volume. It will be seen from the diagram that the chief feature is the provision made for the proper adjustment of grid bias on all three valves. The first one, being a variable-mu valve, has a potentiometer controlling the bias. This, of course, forms the volume control. A potentiometer is also used to give fine adjustment in the case of the detector and assures smooth reaction. The pentode is biased in the usual way.

### —AND WHY!

a modern variable-mu valve being chosen for this stage to enable volume control to be carried out without distortion. Band-pass

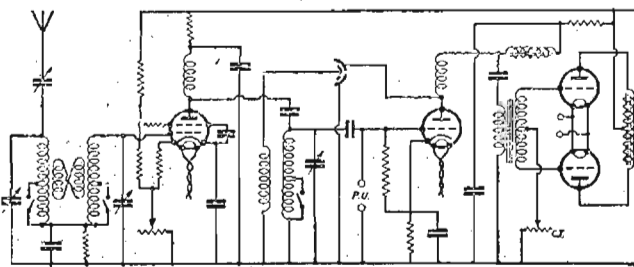

Mr. W. J. Delaney's favourite circuit.

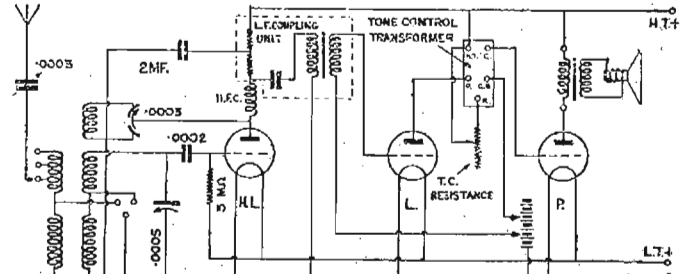

Mr. Frank Preston's favourite circuit.

indeed, it is so much so that there is a decided "cut-off" of high notes. The cut-off is purposely arranged for in the tuning circuit, but all the higher notes can be restored to any desired extent by adjustment of the variable resistance operating on the tone-control transformer. It will be observed that an L.F. coupling unit is employed between the detector and first L.F. valves, and this also serves to decouple the anode circuit of the former valve. A permanent magnet moving coil speaker (complete with suitable input transformer) is connected in the anode lead to the last valve.

Battery feed is illus-

tuning is employed to enable a good standard of selectivity to be attained without distortion, and the signals from these two stages are finally passed to the output stage consisting of two super-power valves in push-pull. A moving coil loud-speaker

I do not use band-pass tuning, because I hardly think it worth the extra expense and complication. Any loss of high notes due to side-band cutting is compensated for by using a transformer with a rising characteristic and a pentode power valve.

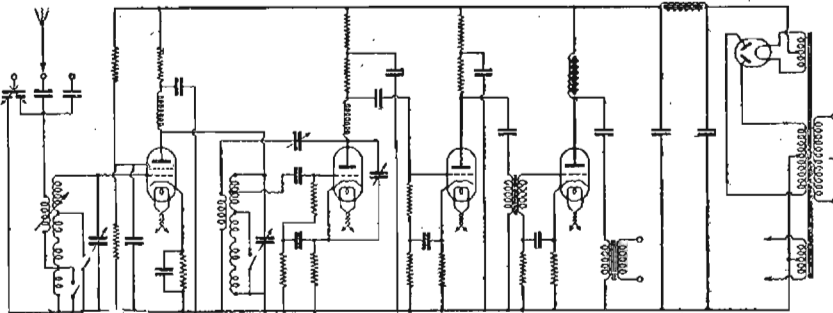

Mr. W. J. Barton Chapple's favourite circuit.

The two tuning condensers are ganged, as I dislike working two knobs in addition to the reaction. However, the condenser has a small knob concentric with the main dial for panel control of the trimmer. An L.F. transformer of generous dimensions with, as I said before, a rising characteristic, is employed in preference to the popular parallel-feed unit partly

(Continued on page 64)

# The ONLY Metallised S.G. High-Mu Detector and Economy Power Pentode SET you CAN build for yourself!



**INCLUDING WALNUT CABINET & SPEAKER**  
**£6.5**

**POST COUPON BELOW FOR YOUR COPY - OR ASK YOUR DEALER**



**FROM GREAT LISSEN**  
**FREE CHART**

Lissen have published a 1/- Constructional Chart, giving the most detailed instructions ever printed for the building of a wireless set. Every part, every wire, every terminal is identified by photographs. This new LISSEN SKYSCRAPER KIT SET is the only one on the market that you can build yourself employing a Metallised Screened Grid, High Mu Detector and Economy Power Pentode Valve. Around these three valves Lissen have designed and produced a home constructor's kit the equal of which there has never been before. It is the only battery set delivering such power—yet the H.T. current consumption is far less than that of the average commercially designed 3-valve set.

**KIT ONLY INCLUDING METALLISED S.G VALVE · HIGH MU DETECTOR & ECONOMY POWER PENTODE**

**89/6**

You buy the Lissen Skyscraper Kit complete with valves—a Lissen Metallised S.G., a High Mu Detector, and a Lissen Economy Power Pentode Valve—and the price is only 89/8. Or you can buy the Lissen Walnut Console Skyscraper Cabinet and Loudspeaker combined as illustrated. It holds all batteries, and accumulator and loudspeaker as well. It makes everything self-contained. A special Lissen Pentode Matched Balanced Armature Loudspeaker of great power is supplied with the cabinet and the price of the Skyscraper Kit complete with valves, and this cabinet and loudspeaker is only £6 5s.

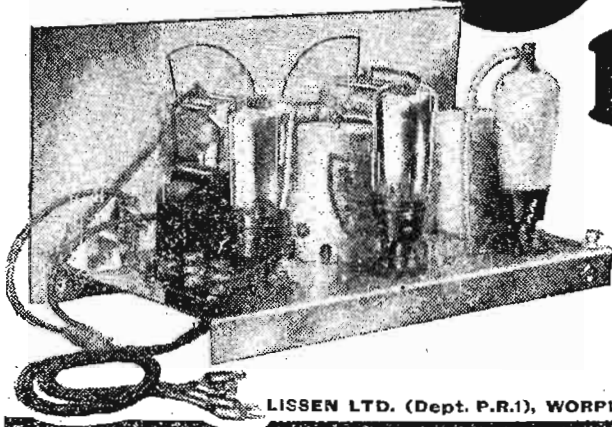

**LISSEN SKYSCRAPER 3 KIT**

**POST THIS COUPON**

Please send me FREE copy of your 1/- Skyscraper Chart.

Name .....

Address .....

..... P.R.I.

LISSEN LTD. (Dept. P.R.1), WORPLE ROAD, ISLEWORTH, MIDDLESEX.

For Wiring Diagram  
See the Free Blue Print  
given with this issue.



IT is far easier to design a good set than to invent a good name for it; we have titled this The Long Range Express in an effort to convey that the set will receive distant

stations, and that you may quickly tune them in. If we have failed to convey this to you, we certainly have not failed to do what we set out to achieve so far as the set itself is concerned. The set was designed to incorporate the new Cossor variable mu valve, and as a result of many weeks testing and matching we have finally arrived at the design shown here and which, we feel, fully justifies the headline at the top of this page, "The Set of the Year." For we are not indulging in extravagant language when we describe it as a go-getter. Station after station is brought in as the two tuning controls are operated.

Most modern battery sets appear to be designed for those many listeners who cannot afford mains-driven receivers and seldom for listeners who cannot use

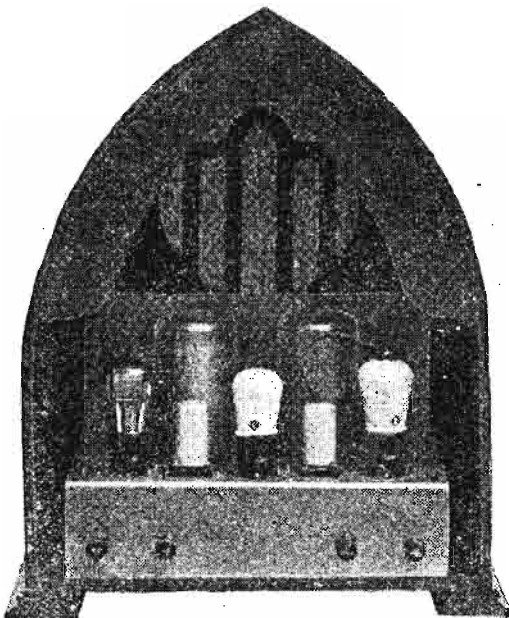

Fig. 1.—Rear view of the very attractive cabinet of the Long Range Express, showing the neat arrangement of the chassis.

# THE LONG RANGE

A Fine and Ultra-Modern Variable Mu Screened-Grid Detector and range, plenty of power, and knife-edge selectivity. It has been s

electric sets because their house is not equipped with electric light. This receiver is definitely designed as a first-class battery set to meet the demand for a really efficient instrument for use with batteries and is not a set designed to spare the last penny; on the other hand, expense has been kept within very reasonable limits.

The set here described has been developed on up-to-the-minute lines, and contains refinements that are seldom met with in a battery set, while it is probably true to say that so many refinements have never before been included in one receiver.

Many constructors are under the impression that real tone and volume are not to be expected from a battery-driven set, but this is not true of the Long-range Express Three, which achieves remarkable reproduction owing to the tone correction and other advanced features described below.

### Outstanding Features

The constructor will naturally be interested to know what points of design make the Long Range Express such an outstanding receiver. First of all, the set has been definitely designed round valves, each picked to perform a separate function, and not the reverse way, which is too often the case; a moment's reflection will show that the characteristics of a valve cannot be made to suit the circuit to any extent, but it is possible by careful design to make the circuit suit the valves.

Starting a survey of the set in a logical order, attention is first drawn to the aerial coil, which has the distinction of having a separate winding for aerial and grid; this arrangement keeps the dial readings reasonably constant with various types of aerials, and also minimizes some form of local interference, whilst, in addition, tuning is considerably sharpened.

The screen-grid valve takes the form of a variable mu valve, which gives perfect control of volume and permits selectivity to be adequately controlled, while distortion on the local station, so common with the ordinary S.G. valve, is completely avoided. The next point to engage attention is the detector valve, which employs shunt-fed transformer coupling, permitting the transformer to give correct bass response—a feature that is at once apparent when listening to the Long Range Express.

It should be fully understood that this arrangement gives absolutely true bass, and not the boom effect associated with many foreign receivers. It may be pointed out that this arrangement also has the effect of making reaction delightfully smooth when used in conjunction with a well-designed coil.

### The Output Stage

This is of considerable importance, and reference to the theoretical

circuit will show that considerable care has been taken. A pentode is used to ensure a really generous output for a low value of H.T. consumption, while a centre tapped

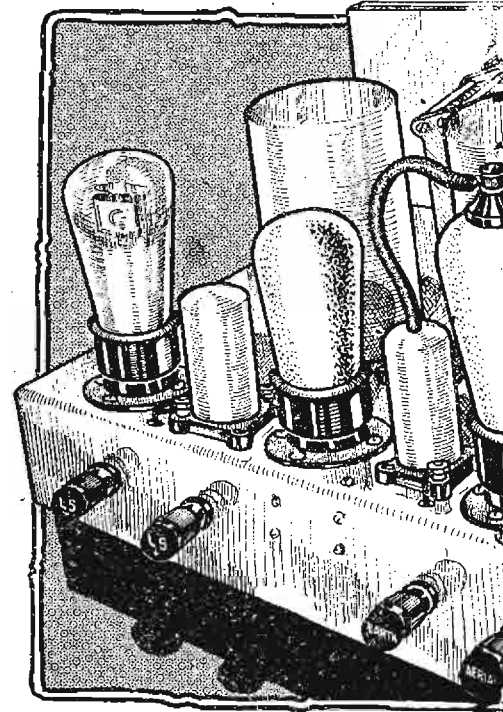

Fig. 2.—Perspective view of the set, showing lay-out. Compare this sketch

### LIST OF COMPONENTS FOR THE

(Variable Mu,

- 2 Polar No. 2 .0005 mfd. Variable Condensers.
- 1 Pair Tannoy Coils.
- 1 Wearite Standard Screened H.F. Choke.
- 1 Wearite Special Screened H.F. Choke.
- 2 T.C.C. .0001 mfd. Type S. Fixed Condensers.
- 1 T.C.C. .0001 mfd. Upright 3-clip type Fixed Condenser.
- 1 T.C.C. .01 mfd. Type S. Fixed Condenser.
- 1 mfd. Mansbridge Type Condr. (Lissen).
- 2 mfd. Mansbridge Type Condrs. (Lissen).
- 1 Dubilier 30,000 ohms. 1 watt fixed resistance.
- 1 Dubilier 10,000 ohms. 1 watt fixed resistance.
- 1 Lissen 2 megohm grid leak.
- 2 Clix 4-pin chassis mounting valve holders.
- 1 Clix 5-pin chassis mounting valve holder.
- 1 Varley Nicore II, No. D.P.2, L.F. Transformer.
- 1 Wearite 16 Henry 15 Ma. L.F. choke.
- 1 Wearite Ganged Wave-change switch.



OF THE YEAR

# THE EXPRESS THREE

and Pentode Set, incorporating the very latest components. It has very wide range, specially designed by our experts, and is here described by PERCY RAY.

NEXT WEEK:  
Adjusting and Operating the Long Range Express.

output choke is provided in order to match the impedance of the average loud-speaker to suit the correct load of the valve. All loud-speakers, except

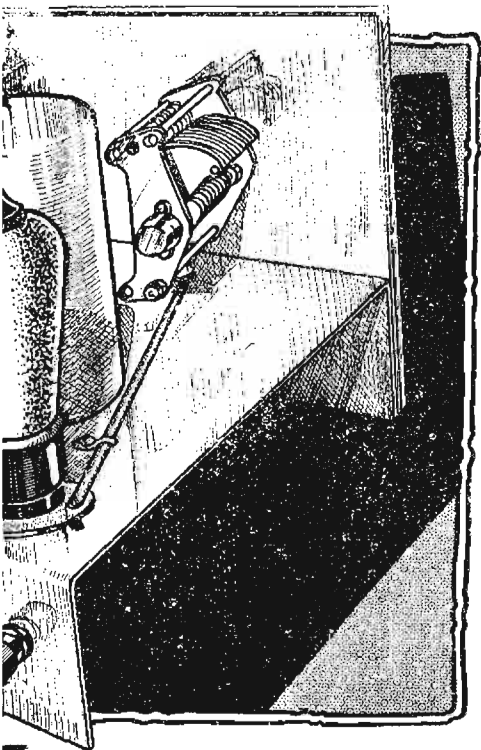

The simplicity of the above-chassis wiring and the photograph below.

moving coil types, have characteristics that make them unsuitable for use with a pentode valve, which is the reason why the enormous advantages of this type of valve are not generally realized. This fact has been taken into account in the design of this set, and the necessary compensation fitted which takes the form of a resistance and condenser connected across the loud-speaker terminals. A pentode valve should never be used without this tone compensator unless a moving coil type of loud-speaker is used. After explaining the details of this receiver it will not be necessary to warn the constructor that it is absolutely fatal to change any of the components or to vary the layout a single inch. Arrangements have been made to have available a metal chassis ready drilled with perfect accuracy, so that every Long Range Express that is built will give the same remarkable performance as the designer's original. The blue print available will naturally be the chief guide to assembly, but there are one or two points that should be carefully noted, as accidents may occur or part of the assembly may have to be pulled down to obtain access for fitting certain components, unless the correct order of procedure is preserved.

### The Assembly

Begin by mounting the valve-holders, taking care to fix them with their terminals in the position shown on the blue print, also not overlooking the fact that the five-pin holder has to be at the end nearest to the loud-speaker terminals.

It is advisable not to fix the coils until all other components are secured in position, as there is danger of pulling one of the leads and cutting the insulation on an edge of aluminium; the reason for the flexible leads is to obviate the uncertainty of small terminals in impossible positions, which is a fault found with most other coils.

Next, complete the top of the chassis, being careful to mount the standard choke with countersunk head screws, otherwise one of the underside components is prevented from lying flat.

When all the top components are fixed, with the exception of the

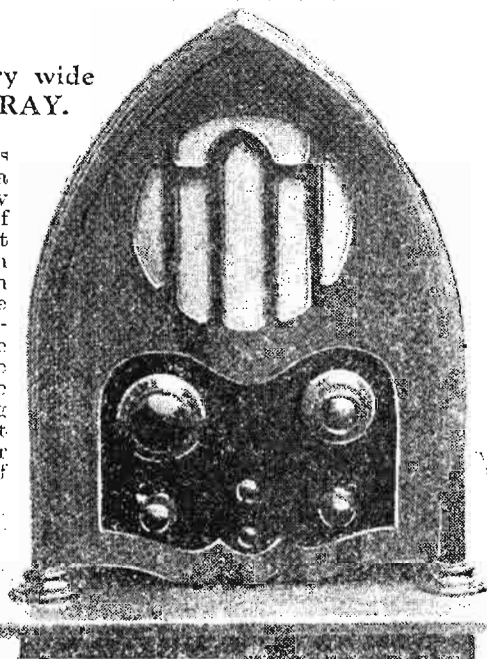

Fig. 4.—This photograph very clearly shows the extremely attractive lines of the Panel and Cabinet of the Long Range Express. The two larger dials are the tuning condensers, the top centre knob is the wavechange switch, the lower centre the on-off switch, the left lower knob the volume control, and the right lower knob the reaction Condenser.

coils, the lower side of the chassis may be commenced, but do not attempt to reverse this order. The two Wearite chokes earth their metal cans by means of an eyelet on one of the fixing holes, it is therefore imperative that these eyelets should not be interfered with, but that a screw of the correct size be used.

Next mount the coils in position; access is obtained by removing the can from the base, which is detached by a small rotary movement like removing an electric lamp

## LONG RANGE EXPRESS THREE

Screened-Grid)

- 1 Lissen Precision .0003 mfd. Reaction condenser.
- 1 Lissen 3 point "On and Off" switch.
- 1 Lewcos 50,000 ohms. potentiometer.
- 4 Bulgin Panel Pointers.
- 4 Clix Spade terminals (Aerial, Earth, L.T.+, L.T.-).
- 6 Clix Wander Plugs (G.B.—2, G.B.—1, H.T.+, H.T.+1, H.T.+2, G.B.+).
- 3 Coils Lewcos Glazite.
- 1 Paroussi Long Range Express Three 16 gauge metal panel (12in. by 8in. and baseboard 12in. by 13in.)
- 1 Bulgin 7-way battery cord.
- 1 Celestion Soundex Moving Coil Loud-speaker.
- 2 Ediswan 60-volt, super capacity H.T. batteries.
- 1 Lissen 9-bolt grid bias battery.
- 1 Ever Ready 2-volt 35 ampere hour L.T. accumulator.
- 3 Corsor Valves 220 V.S.G., Metallized, 210 H.F., Metallized, 220 H.P.T.
- 1 Osborn No. 235 Cabinet.

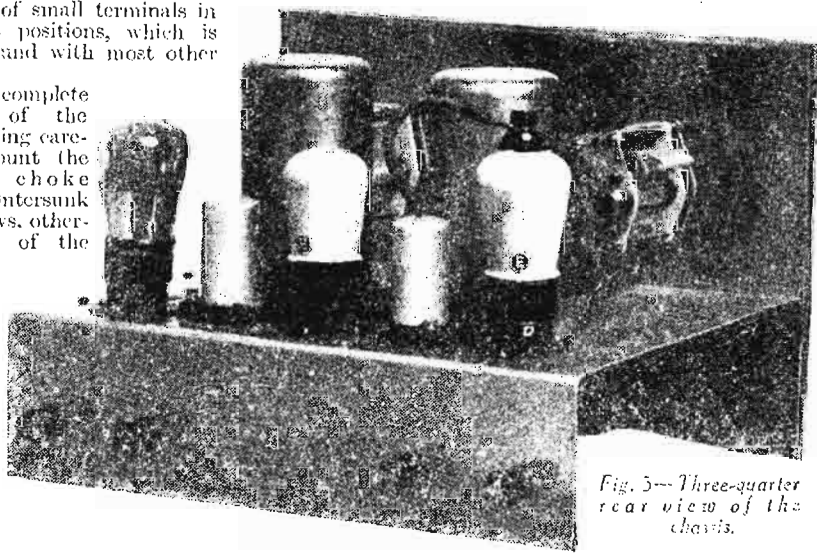

Fig. 5—Three-quarter rear view of the chassis.

from its holder. When the coil leads have been slipped through their corresponding holes in the base and the latter bolted in position, the cans should be replaced and turned firmly to lock them in position; it is advisable to connect the leads to their respective points so that they are out of the way. As it is difficult to make a join in these leads, make sure that the correct lead is selected and measure twice before cutting.

**Wiring Up**

The wiring-up can now be commenced; the valvholder legs will only comfortably take one piece of Glazite, which should be used for making the connections, so when making the connection between the three positive filament legs a single piece must

be used. Many of the leads are taken to the chassis, and in some cases the nearest point has not been taken; there is a reason for this, so do not be tempted to vary the connecting points shown.

When the internal connections are completed and checked, the flexible battery leads can be added, the actual length being governed by the individual requirements, but in general it may be remarked that too long leads are as troublesome as unduly short ones.

**On the Ether**

Next make sure that all connections are quite in order, as a mistake may be expensive. If satisfied that everything is exactly in accordance with the illustration, connect the accumulator, grid-bias battery and,

lastly, the high tension battery; with the exception of H.T., this order is the safe sequence. Now insert the valves in their correct order and connect the lead from the choke to the top terminal of the variable-mu valve. Insert the H.T.— plug, connect aerial, earth and loud speaker and switch on and the set will be ready for its first run on the ether. A fuse is not fitted, as these components usually fail to give the protection they should, and it is better to be without a fuse and use adequate care than rely on a fuse which fails.

Set the wave-change to the waveband required—in for long and out for short. Set reaction condenser to minimum (plates out of mesh) and volume control to maximum. Tuning is, of course, effected by the

*(Continued on page 39.)*

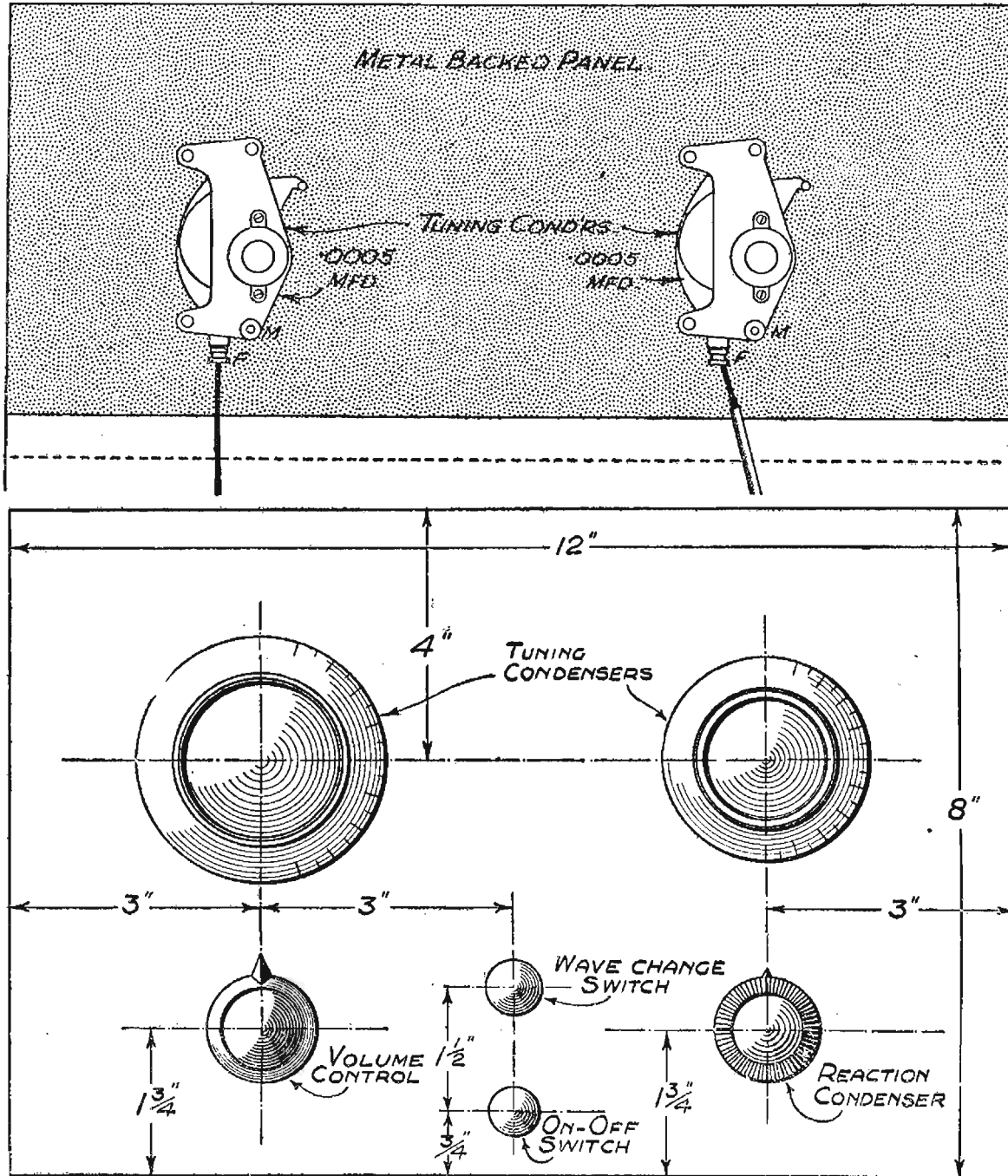

These diagrams show (top) back of panel and (below) front of panel arrangement of controls.

HOW  
STUDIO  
SOUNDS ARE  
PRODUCED

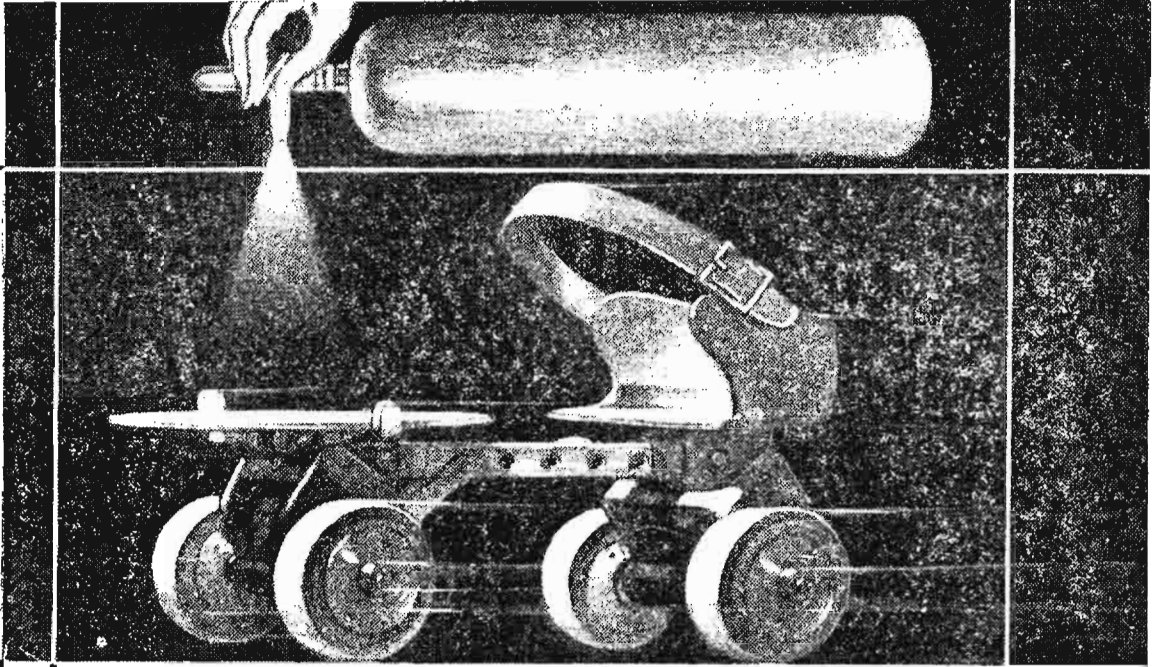

## Here's your radio railway train



Skrill whistles, hissing steam, the clank of wheels, the gathering speed . . . all these noises are produced in the Effects Studio by means of simple mechanical devices like the roller skate and the compressed air cylinder you see above. The result is amazingly realistic ; and that realism you can retain in your reproduction by using the pure power of a Lissen Battery in your set. There is a process used exclusively in this Lissen Battery which produces power of remarkable purity ; power so sustained that over prolonged periods of time it remains steady, noiseless and abundant always. Every radio dealer sells the Lissen High Tension Battery : ask for it firmly by name.

# LISSEN H.T. BATTERY

lasts longest and provides a pure high tension current  
that will give stage realism to your radio drama!

# THE WHY AND THE WHEREFORE—1

A series of weekly articles dealing with the function of the various components of a Broadcast Receiver

By JACE

**B**EFORE we can commence our analysis of the receiving set it is necessary for us to briefly go over the method which is adopted to get the broadcast matter to our homes. There is no need to delve deeply into the technical side of the transmitter, but in order that we can understand certain functions in the actual receiver, we must acquaint ourselves with the manner in which the broadcast music or speech is converted into a form which may be transmitted far and wide. One or two of the terms must be remembered as

all the different transmitting stations may work at the same time without confusion, it is necessary to keep each station on one particular path, and this process is known as tuning. The majority of you know how a banjo or violin string alters its tone as it is tightened, and this provides a very good example of the tuning of a wireless circuit. If the string is just joined to the key and the tail-piece of the instrument without any tension, it will give off a certain note. Now, as the key is turned, and tension applied, the tone of the string will rise simply because it cannot vibrate so freely. Now in the transmitting circuit, and directly connected to the aerial, is a tuning device which causes the H.F. oscillations which we have just discussed, to be sent out at a definite number of times per second. This tuning is known as the "frequency," and is referred to by the term "kilocycles." If you look at the Wireless Programme column in your daily paper, you will see beside the London Regional programme, the figures 356.3 metres, and then, usually in brackets, 842 kc/s. This last figure is the number of oscillations per second, and is really the best method of referring to individual broadcasting stations. The other figure, in metres, is the distance from the top of one oscillation to the top of the next.

this insulating material is in turn attached to the pole or mast. As the oscillations travel on the surface of metal, we must provide as large a surface as convenient, and this is most readily carried out by using stranded copper wire. Copper because of its conductivity, and stranded, in order to get the large surface without using an unduly large thickness of single wire. The most common type of wire consists of seven strands of No. 22 gauge wire—familiarly referred to as 7/22's.

We have seen how one end of this aerial wire has had to be insulated, and now the other end has to be led down to the tuning device in our receiver. Still bearing in mind the tendency of the oscillations to get to earth, we must take care that nowhere does the aerial wire come close to, or in contact with, anything connected to earth. If the wire is led in through a wall or window, a porcelain or ebonite tube should be used to conduct the wire into the house (Fig. 3).

## The Tuning Coil and Condenser

We have now got to provide a means for putting our aerial in tune with the transmitting aerial, and this gives us our tuning coil and tuning condenser. In effect, we use a length of wire, which, for convenience, is wound round a tube, to add to the length of wire which is suspended outside the house. In order to avoid altering the amount of wire for each particular frequency which we wish to receive, we connect across the tuning coil a variable condenser, and these two components form a circuit which, according to the size of the coil and the size of the condenser, will tune over a wide band of frequencies (Fig. 2). The most efficient condition is met when the amount of condenser which has to be added is small. That is, a frequency of say 1,000,000 cycles—which is 1,000 kc/s, may be obtained with a coil of 5 or 6 turns of wire and a condenser of very large dimensions; or a coil of 60 turns and a very small condenser. The latter arrangement will, however, pass on the largest amount of energy at that particular frequency. We see, therefore, why dual-

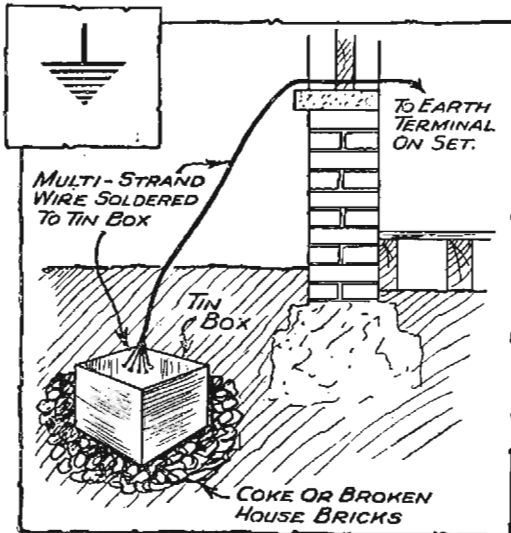

Fig. 1. A good "earth" makes all the difference. Here is an excellent arrangement.

they will be referred to in certain parts of the receiving apparatus, but we shall only mention those technical terms which are absolutely necessary.

Everyone knows, nowadays, that the broadcast performance takes place in a studio, and that the most important item in the studio is the microphone—familiarly referred to as "mike." This piece of apparatus is, in effect, a glorified telephone mouthpiece—that is, it picks up the sounds which are made in its vicinity and converts them into electrical impulses. These impulses are passed into certain apparatus, which amplifies or magnifies them in order that they shall be strong enough to operate certain other parts of the transmitter. Another part of the transmitting apparatus generates electrical currents, which change their form very rapidly, and this particular form of current is known as "High Frequency Oscillations." This is one of the terms you will have to remember, and it simply means that the current "oscillates" a large number of times per second.

## The Tuning of a Wireless Circuit

The electrical currents from the microphone are conveyed to this H.F. generator, and by means of the apparatus the two different currents are combined, and in the combined form are radiated, or shot off, from the transmitting aerial. In order that

## The Aerial

We have now got, travelling through the air at a definite frequency, high frequency oscillations upon which are superimposed the sounds received by the microphone, and we can now set about the reception of these sounds. Obviously, the first thing to do will be to "tap" the waves or oscillations, and therefore we must erect something in the air in the path of the waves. Now a peculiarity of these oscillations is that they adopt the same course as lightning—that is, they take the easiest path to the earth. Therefore, any conductor of electricity erected in the air and joined to earth will act as a lightning conductor does, and convey the oscillations to the ground. This gives us, therefore, our first consideration in erecting our aerial—a barrier must be placed at the end so that the oscillations are directed through our receiver and are not permitted to travel down the pole or mast to which the aerial is attached. Porcelain, ebonite, or any good insulating material has therefore to be attached to the ends of the wire which we use for the aerial, and

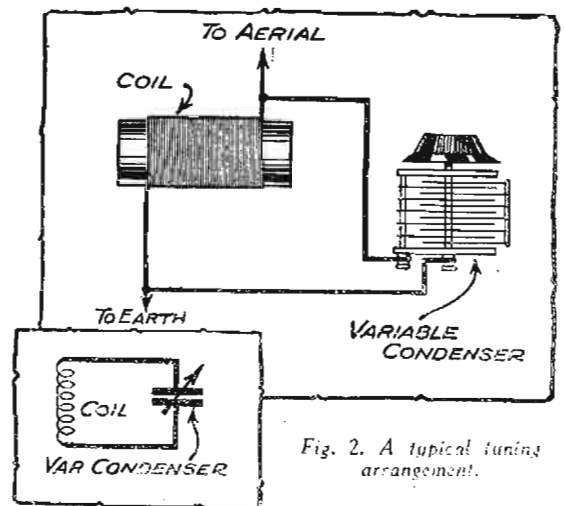
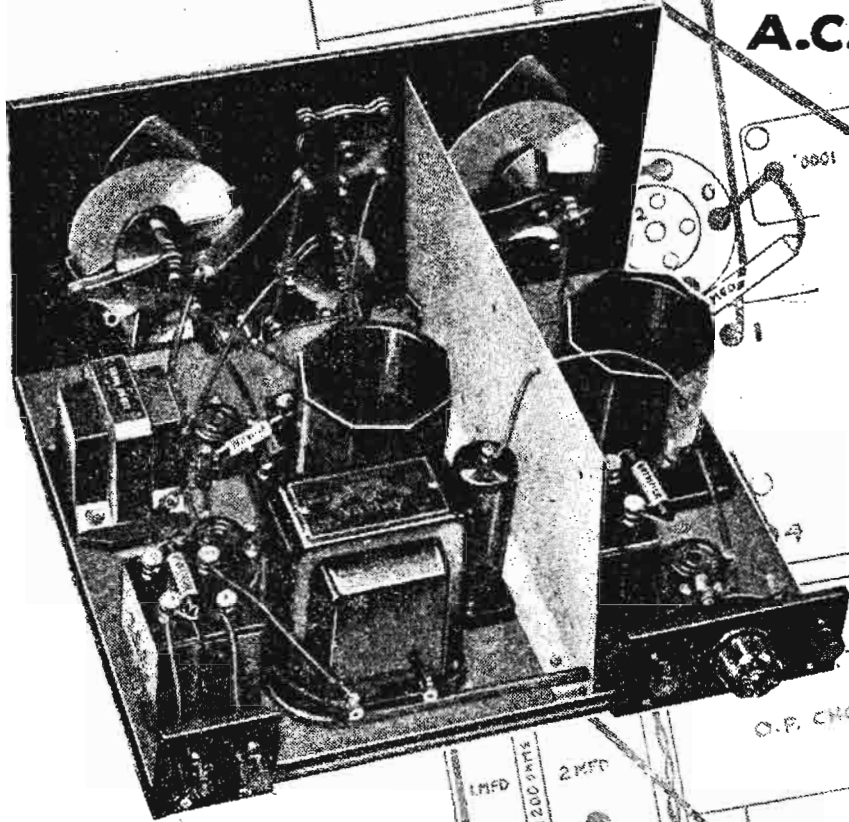

Fig. 2. A typical tuning arrangement.





# Convert your set to the KENDALL-PRICE S.C.3 A.C. MODEL



*A powerful set which will give you a minimum of thirty medium and long wave stations—and probably double this figure—as well as short wave stations from all parts of the world.*

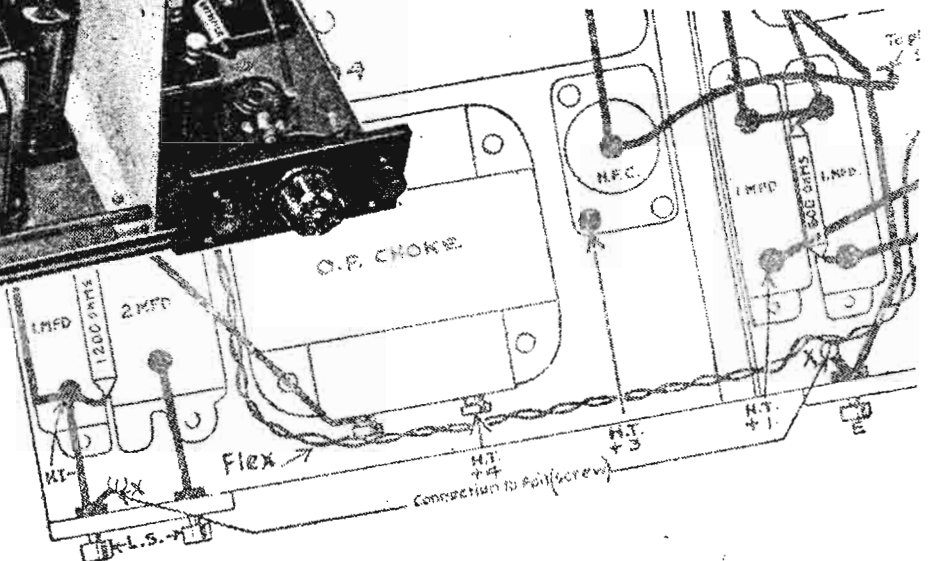

**Free**

Mr. G. P. Kendall, B.Sc., the designer of many famous sets, and his assistant, Mr. H. D. Price, the famous short-wave experimenter, have written a book containing complete instructions, photographs and diagrams of ten modern circuits both battery and mains-operated. It shows you how, at a cost of a few shillings, you can bring your present set right up to date. At its published price of 1s. it represents remarkable value-for-money. Full-sized dimensioned Blueprints of these ten wonder circuits are also available at the exceptionally low price of 1s. for the set of ten. Send 1s. in stamps for the blueprints and we will also send you a FREE copy of the "Kendall-Price" Book. Post coupon now!

*The Kendall-Price Book is packed full of useful information which will prove invaluable to you, whatever type of set you are using. Even if you are satisfied with your present set you should read this wonderful book.*

To Ready Radio Ltd. (Book Dept.), Eastnor House, Blackheath, S.E.3.

I enclose 1/- for ten full-sized blueprints. Please send me in addition—FREE—the wonderful Kendall-Price Book of ten circuits.

Name.....

Address.....

Proc. W. 1b.

# READY RADIO

Ready Radio Ltd., Eastnor House, Blackheath, S.E.3.

# Do You Understand Your Loud-Speaker?

Don't always blame your receiver when results are not up to standard. It is more than likely that your speaker does not match the output valve

**M**OST listeners look upon a loud-speaker and a wireless set as being two entirely separate pieces of apparatus, whereas actually they are two members of the team working together for a common purpose, and in common with all other teams the efficiency is that of the weakest link. If a set of only moderate efficiency is possessed there is little point in using a loud-speaker of the first class. It is

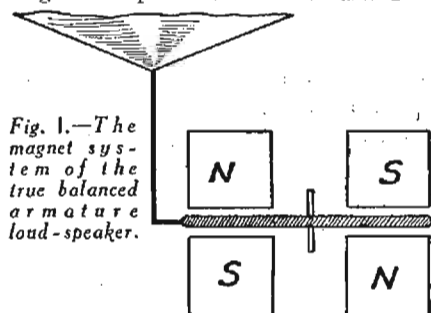

Fig. 1.—The magnet system of the true balanced armature loud-speaker.

a common mistake to fit a moving coil loud-speaker to a set that is incapable of giving an output worth listening to as, after all, the loud-speaker can only deliver what it is given, and if any imperfections are present the better the loud-speaker the more noticeable they will become.

The numerous types of loud-speakers that are available at the present day are extremely confusing, and doubtless a little light on the matter will be welcomed.

A good loud-speaker is a thing that the owner may be justly proud of, and a little trouble taken to ensure that it is working efficiently is well worth while.

### Old Telephones

Many loud-speakers that are offered for sale are little more than a telephone ear-piece with some means for attaching the cone; in fact, there is actually one loud-speaker which may be seen in many shops that actually uses the absurdly small magnets taken from obsolete headphones.

There are many so called balanced armature loud-speaker units available: the expression "so called" needs qualifying, as it is probably true to say that there is not more than one or two true balanced armature units obtainable. Fig. 1 indicates the balanced armature principle, and it will be noticed that the armature is pivoted in the middle and that the magnets are so arranged that both ends of the armature have equal magnetic forces brought to bear. Fig. 1A indicates the general idea of what is popularly supposed to be a balanced armature. It will be seen that the armature is pivoted at a distance from the magnet, and in order to prevent the former from flying up and hitting one of the pole pieces some form of mechanical damping, such as a spring or a piece of rubber, has to be used. This, unfortunately, makes a compromise between sensitivity and volume handling capacity necessary, as a light spring will render the loud-speaker sensitive, but will not stop the armature

### An Informative Article by HAROLD DOWNING

from crashing on the magnet when heavy volume is handled, while a stronger spring sacrifices sensitivity.

In spite of this obstacle the popular balanced armature loud-speaker is in general use and well deserves its popularity. This type of loud-speaker usually gives disappointing results with a pentode valve as some means of limiting the impedance is wanted but is seldom fitted. This should take the form of a corrector circuit which is described below.

### The Inductor

The most recent member of the loud-

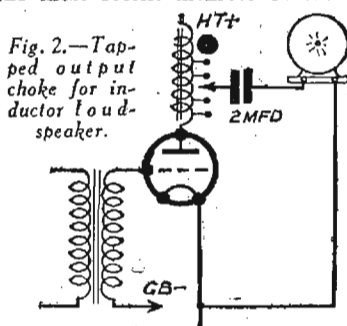

Fig. 2.—Tapped output choke for inductor loud-speaker.

speaker family is the Inductor type or, to give it its full title, the Dynamic Inductor. For use in a home on an ordinary receiving set this type of speaker has, in the writer's opinion, certain drawbacks.

In the first place, the response is very unbalanced, being mostly bass and very little treble, which results in a somewhat choked blanket effect. Many readers probably prefer a slight predominance of the low notes, but, unfortunately, a serious loss of treble results in the characteristic sounds of the low notes being lost.

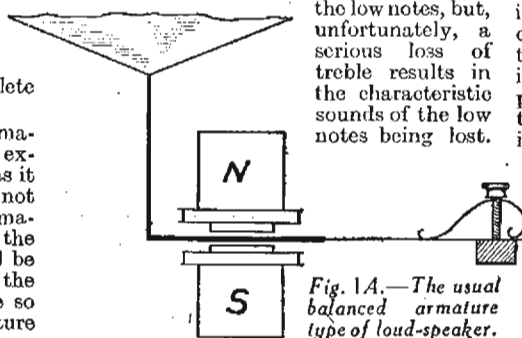

Fig. 1A.—The usual balanced armature type of loud-speaker.

The piano has a range of a little over seven octaves, and ranges from 26 vibrations per second, or cycles as it is called, up to 4,096 cycles at the highest note. Bearing in mind the range of the piano, which is an excellent instrument for comparison, the range of frequencies necessary to make certain sounds realistic will come as a surprise: it is convenient to think of the piano as ranging from approximately 25 to 4,000 cycles.

The sound of footsteps approaching the microphone on a wooden floor requires from

350 to no fewer than 10,070 cycles for its original character to be retained. If a means is arranged to cut off in a receiver the notes between 8,000 and 10,000 cycles a definite difference in the sound of the footstep will be noticed.

The actual range required by various instruments is surprising, in particular a sixteen inch cymbal has no frequencies below about 300 per second, although many people are under the impression that the crash of a cymbal is lower than that of a drum.

Therefore, as the double bass actually goes lower than the piano, and certain stage effects require a range up to 13,000 cycles, it is apparent that the perfect reception of vaudeville requires an amazing band of frequencies that few loud-speakers and amplifiers could cover.

The above illustrates where, in the writer's opinion, the inductor fails, but after all the best loud-speaker from the user's point of view is the one that gives him and his family the greatest pleasure to listen to; if a listener likes a loud-speaker that gives the impression of being low pitched, there is no reason why he should not please himself.

The inductor requires the greatest care in matching its output valve, and some arrangement like that shown at Fig. 2 is highly desirable.

### Moving Coil

The moving coil loud-speaker is rapidly gaining in popularity, and the greatly reduced price of these loud-speakers and the high sensitivity of the latest type indicates that they will very soon be in almost general use. It is a great mistake to think that the moving coil loud-speaker requires a multi-valve set as many are more sensitive than ordinary cones, and when quality of reproduction is considered it has no equal. This type of speaker can be divided into two classes. Those that require a current supplied by an eliminator, or otherwise, to magnetize the iron pole pieces. The other type dispenses with this energy as the pole pieces are made in the form of a permanent magnet but, type for type, the mains energised drive is preferable.

The actual coil of this type of speaker is usually about 5 ohms, and therefore requires a transformer in order that this figure may be raised to suit the valve. Alternatively, some

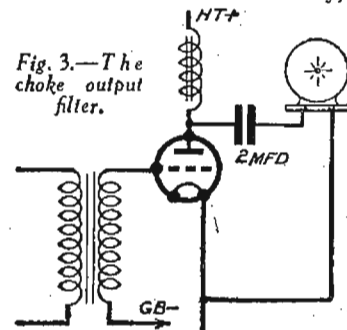

Fig. 3.—The choke output filter.

manufacturers wind the coil to a high resistance to any specification. The majority, however, make a serious mistake as, when asked to supply a loud-speaker to match a particular valve, they wind the coil so that it has the same resistance as the valve impedance.

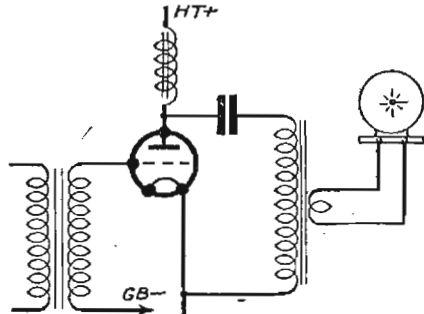

Fig. 4.—A choke-fed transformer for a moving-coil speaker.

Why the manufacturers of a good loud-speaker, who are otherwise well informed, should make this glaring error is a little mystifying. Suppose for example that a loud-speaker is required to match a Cossor 220 XP, it will often be supplied with a resistance of 1,500 ohms, which is the impedance of the valve and has little to do with the matter. The resistance that should have been supplied is 3,500 ohms. The correct figure is arrived at by what is called the optimum load, and is most complicated to work out, but, fortunately, this is unnecessary, as valve manufacturers invariably quote the optimum load of the valve on the slip enclosed in the box. The meaning of the term optimum load is the resistance that a loud-speaker or output circuit must possess in order to allow the valve to deliver its full undistorted output. Generally speaking, it is better to have a valve in excess of that quoted, rather than the reverse, which makes the error in coil winding referred to above more serious than ever.

**Mounting**

Insufficient attention is given to the vital importance of secure loud-speaking mounting. With an ordinary balanced armature chassis, it is perhaps sufficient to use three small screws to hold the rim on to the baffle board or cabinet front, but with moving coil loud-speakers a really secure and rattle-free fixing is essential, especially if large volume is to be handled. Most loud-speaker chassis rims have a felt washer, but this is often too thick to prevent the metal from lightly touching the wood and rattling. It is, therefore, well worth while to cut a washer out of baize or felt and stick it lightly on the loud-speaker cabinet or baffle board; thus a fixing of felt to felt is obtained and the screws can be done up really tightly, that is, if the transformer does not get in the way of the screw-driver, which happens when mounting several well-known types. Whilst mentioning baffle boards, it will be as well to point out that plywood is not ideal for this purpose, although it is extremely strong and cheap. The trouble is that various layers of wood are glued together and pieces of loose glue become detached and set up a scrapy background: when possible pine is one of the best materials to use, as it is soft and almost entirely free from resonance.

**The Output Choke**

Few loud-speakers will work at their maximum efficiency if they are hampered

by the presence of the battery currents flowing through their windings, and it is well worth while, therefore, to build a simple choke output filter as shown at Fig. 3, which, incidentally, has the additional advantage of passing the speech current to earth instead of through the batteries, which often results in motor boating. For an ordinary type valve 25 henrys and upwards should be used, while for a pentode 50 henrys or about should be used.

For a super power valve 20 henrys is adequate, but, of course, higher values may be used. The illustration shows a condenser having a capacity of 2 mfd., but with an ordinary balanced armature speaker 1 mfd. is sufficient, but the higher value will do equally well if already possessed. When using a moving coil loud-speaker with an output transformer incorporated, it is desirable that it should be choke fed in the manner shown at Fig. 4, in order that the transformer core shall not be circulated by the high tension current, and also to prevent back coupling and consequent motor boating. When using a pentode output valve, considerable care must be taken to see that the loud-speaker used has suitable characteristics, or

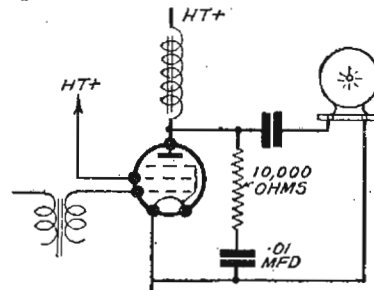

Fig. 6.—Tone corrector for using a standard speaker with pentode.

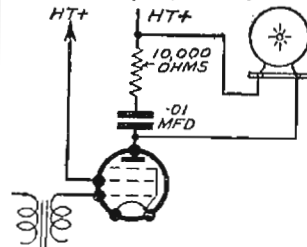

Fig. 5.—The corrector circuit.

alternatively that the circuit is arranged to overcome the shortcomings of the loud-speaker. As already mentioned, it is necessary to use a corrector circuit, except when a moving coil loud-speaker is used. If, however, a corrector circuit proves itself to be necessary with a moving-coil speaker, it indicates that the latter has some peculiar characteristics and is a serious reflection upon its designer.

Fig. 5 shows a simple corrector circuit, which may consist of 10,000 ohms resistance joined in a series with a .01 condenser and connected across loud-speaker terminals. These values will, of course, be unsuitable under certain circumstances, but generally speaking they are satisfactory, and at any rate provide a starting point for experiment.

If desired, the 10,000 ohms fixed resistance can be substituted by a variable one for 25,000 ohms so that tone control is provided. It has been said that the pentode valve does not come up to the ordinary valve in quality of reproduction. This is due to the unsuitability of the average cone type loud-speaker which is really designed to work with a power or super

power valve, but if the corrector circuit is used everything becomes quite satisfactory. When using a pentode valve taking a high H.T. current it is necessary to choke feed, in which case the corrector circuit should be applied, as shown in Fig. 6. As, however, the average loud-speaker is also lacking in impedance, the use of a tapped choke is an advantage. This is diagrammatically shown at Fig. 7.

**Another Problem**

The other problem that may present itself is the use of a moving coil loud-speaker having an output transformer fitted to it that is suitable for a power valve, but it is a simple matter to use it with a pentode valve if a tapped choke is used, it being quite unnecessary, of course, to use the corrector circuit. As it is not easy to ascertain at what point the choke should be tapped, it is advisable to purchase a choke provided with a number of tapings and various ones tried until the best is arrived at. When choosing a loud-speaker, it is necessary to bear in mind the purpose for which it is required: if only moderate volume is required a balanced armature type has much to be said in its favour. If, on the other hand, something like radio gramophone volume is contemplated, a moving coil speaker is essential. When mains are not available, an energised type is not practicable, and a permanent magnet model must be employed. Although this type of speaker is extremely good and will do all that is required of it, it is always advisable to use a mains energised type when possible; also do not forget that the loud-speaker and output valve work as a team and, therefore, it is useless to use a loud-speaker of large size and expect big volume if the output valve is too small and vice versa, and remember that an output valve can only deliver its full amount of undistorted music when the impedance of the circuit connected in its anode is sufficiently high. Fortunately, many loud-speaker manufacturers quote the impedance of their loud-speakers, and it is only necessary to choose the valves that have an optimum load (quoted by their maker) of approximately the same figure.

Free with every copy of next week's issue!

**SPLENDID BOOK**

**"All About Tuning and Tuning Coils"**

**ORDER YOUR COPY TO-DAY!!**

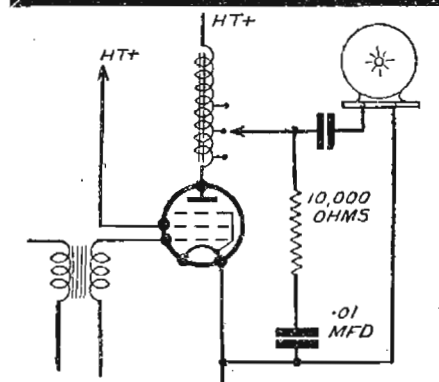
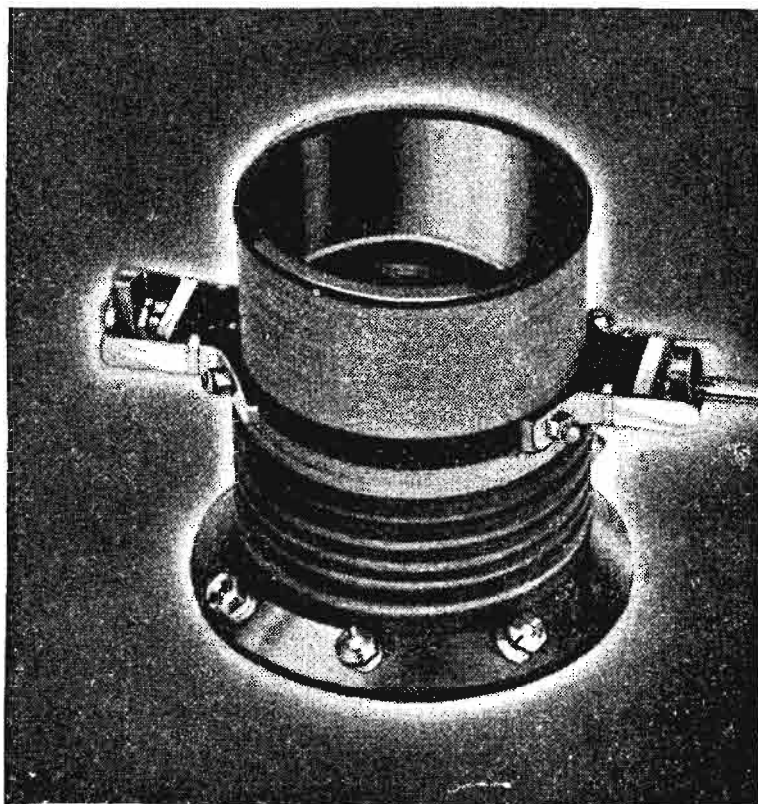

Fig. 7.—Tapped output choke and tone corrector.



# SUPER-SHARP SELECTIVITY FOR THE DOLPHIN THREE



When you build the 'Dolphin' Three you are assured of selectivity and sensitivity far above the average obtained from a Det.-2 L.F. circuit. It incorporates the wonderful Ready Radio Dual Range Coil Unit, fitted with four-in-one control, which acts as combined on-off switch, wave-change switch, selectivity and volume control, thus greatly simplifying wiring and construction. Instructions are included with every unit. From all radio dealers.

PRICE ONLY 10/6

## Bring your set up-to-date with the "MICALOG"

The tuning condenser of the future. Combines all the advantages of a solid di-electric condenser with the efficiency of the best condenser obtainable of any type. Smooth and silent action, self-cleaning plates, positive contact to moving vanes.

Capacities .0003 and .0005 mfd.

Price 3/6 each.

### BRING YOUR SET UP-TO-DATE.

Post coupon with 1/- in stamps and we will send you 10 full-size blueprints of 8 modern battery and mains sets and 2 power units. We will also send you a FREE copy of the new 1/- Kendall-Price Book, packed full of useful information.

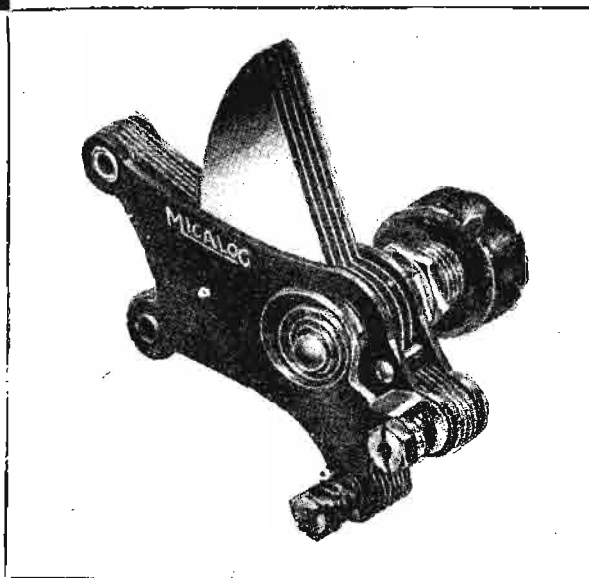

# READY RADIO

Ready Radio Ltd., Eastnor House, Blackheath, S.E.3. Lee Green 5678.

To Ready Radio Ltd. (Book Dept.), Eastnor House, Blackheath, S.E.3.

I enclose 1/- for ten full-sized blueprints. Please send me in addition—FREE—the wonderful Kendall-Price Book of ten circuits.

Name .....

Address.....*Price, W.10.*

# Direct Radio

**159  
BORO'  
HIGH  
STREET**

## LONG-RANGE EXPRESS THREE

2 Pular No. 2 .0005 mfd. variable condensers ..	13 0
1 Pair Tannoy coils ..	15 6
1 Wearite Standard screened H.F. choke ..	3 6
1 Wearite special screened H.F. choke ..	4 0
2 T.C.C. .0001 type S fixed condenser ..	2 6
1 T.C.C. .0001 upright 3 clip type fixed condenser ..	2 4
1 T.C.C. .01 type S fixed condenser ..	2 6
3 Dubilier 1 mfd. type condensers 9200 ..	8 3
2 Dubilier 2 mfd. mansbridge type condensers 9200 ..	11 3
1 Dubilier 50,000-ohms 1-watt fixed resis. ..	1 0
1 Dubilier 10,000-ohms 1-watt fixed resis. ..	1 0
1 2-megohm grid leak ..	1 0
2 Clix 4-pin chassis mounting valve holders ..	1 4
1 Clix 5-pin chassis mounting valve holder ..	10
1 Varley Nicore II No. DP2 L.F. transformer ..	11 6
1 Wearite 16-henry 15 m-a L.F. choke ..	10 0
1 Wearite ganged wave change switch ..	5 0
1 .0003 mfd. reaction condenser ..	2 6
1 3-point on-off switch ..	1 6
1 Lewcos 50,000-ohms potentiometer ..	3 0
4 Bulgin panel pointers No. 3 ..	4
4 Belling-Lee spade terminals (Aerial, Earth, LT, LT) ..	8
6 B-Lee wander plugs (GB2, GB-1, HT, HT1, HT2, GB) ..	1 0
3 Coils Lewcos Glazite ..	1 6
1 Long-Range Express Three 16 gauge metal panel 12 x 8 and baseboard 12 x 9 1/2 ..	4 6
1 Bulgin 7-way battery cord ..	2 6
Screws, etc. ..	2
<b>£5 12 0</b>	

3 Cossor valves 220 VCS metallised, 210HF metallised, 230DT metallised ..	2 1 0
1 Cabinet ..	17 0

- Kit No. 1** less valves and cabinet £5.12.0 or 10'6 down and 11 monthly payments of 10'6
- Kit No. 2** with valves, less cabinet £7.13.0 or 14' down and 11 monthly payments of 14'
- Kit No. 3** with valves and cabinet £8.10.0 or 15'6 down and 11 monthly payments of 15'6
- Kit No. 4** with valves, Consolette cabinet, R. & A. Challenge M/C Speaker, Siemens Power batteries, Oldham acc., or 22' down and £12.10.0 or 11 monthly payments of 22'

**Recommended Accessories:**

2 Siemens 60-volt Power H.T. batteries ..	1 4 0
1 Siemens 9-volt G.B. battery ..	1 0
1 Oldham 0-75 2-volt 75 ampere hour L.T. accumulator ..	12 6

## OFFER

*Every Component Guaranteed*

**KITS for CASH**

**KITS for C.O.D.**

*Any components supplied separately*

**KITS on EASY PAYMENTS**

**TELSEN Kits to Manufacturers' Specification:**

**Ajax Three Kit £3.1.6.** 10/- down and 8 monthly payments at 7/6.

**Ajax Three Valve Kit £4.4.3.** 10/- down and 11 monthly payments of 7/6.

**Ajax Three Valve Cabinet Kit £4.15.0.** 15/- down and 11 monthly payments of 8/6.

**Jupiter Three Kit £3.17.0.** 10/- down and 10 monthly payments of 7/6.

**Jupiter Three Valve Kit £5.18.0.** 15/- down and 11 monthly payments of 10/6.

**Jupiter Three Valve Cabinet Kit £6.0.0.** 20/- down and 11 monthly payments of 10/6. With Special Cabinet. Free Blueprints.

**"RADIO FOR THE MILLION" Station-master Three Sealed Kits.** Battery Model "A" with Table type Cabinet and valves £5.11.0. Deposit 15/- and 11 monthly payments of 10/-. Battery Model "B" with Console type cabinet, Valves and Celestion Speaker. £7.10.0. Deposit 20/- and 11 monthly payments of 13/-.

## DOLPHIN STRAIGHT THREE

1 Ready Radio dual range coil unit ..	10 6
1 J.B. .0005 mfd. variable condenser Popular Log line with slow motion dial ..	8 6
1 .00015 mfd. reaction condenser ..	2 6
1 Bulgin Transcoupler ..	11 6
1 Sektun colt 5-1 L.F. transformer ..	4 9
3 W.B. 4-pin valve holders ..	1 6
1 T.C.C. .0002 mfd. fixed conds. 3-terminal type ..	2 4
1 2-meg. grid leak ..	10
3 Belling-Lee terminal mounts ..	2 0
6 Belling-Lee terminals (Aerial, Earth, L.S., L.S., Pick-up +, Pick-up-) ..	1 3
1 5-way battery cord ..	1 9
4 Belling-Lee wander plugs (GB, GB-1, GB-2, GB) ..	8
1 Permcot ebonite panel 12ins. x 7 ins. ..	3 0
1 Wooden baseboard 12ins. x 8ins. ..	9
2 Bulgin panel mounting dial pointers No. 3 ..	4
1 Coil Glazite Lewcos ..	6
Screws, etc. ..	4
<b>£2 13 0</b>	

3 Mullard valves PM2DX, PM1LF, PM2 ..	1 2 9
1 Special Dolphin Consolette cabinet ..	1 1 0

- Kit No. 1** less valves and cabinet £2.13.0 or 6' down and 9 monthly payments of 6'
- Kit No. 2** with valves, less cabinet £3.15.9 or 7' down and 9 monthly payments of 7'
- Kit No. 3** with valves and cabinet £4.16.9 or 9' down and 9 monthly payments of 9'
- Kit No. 4** with valves, cabinet, batteries, R. & A. type 50 loud-speaker, aerial and earth £6.19.3 or 13' down and 11 monthly payments of 13'

**Recommended Accessories:**

1 Siemens 120-volt H.T. battery ..	13 6
1 Oldham 2-volt accumulator ..	9 0
1 Siemens 9-volt G.B. battery ..	1 0
1 R. & A. type 50 loud-speaker ..	15 0
1 R. & A. Bantam loud-speaker ..	1 7 6
1 Selectanet aerial ..	2 6
1 Selectanet earth ..	1 6

**READY RADIO KITS.** Meteor S.G.3 Kit (with valves) £5.7.6, or 10 monthly payments of 12/6. Cabinet Model (as above with Cabinet and Moving-coil speaker) £8.17.6, or 12 monthly payments of 17/-. 303 Kit (with valves) £3.10.0, or 7 monthly payments of 11/9. Cabinet Model (as above with Cabinet and Moving-coil Speaker) £6.17.6, or 10 monthly payments of 16/-.

## CASH, C.O.D. AND EASY PAYMENT EXPRESS ORDER FORM.

To: Direct Radio Ltd., 159, Borough High Street, London, S.E.1.

Please dispatch to me at once the following goods.....

- (a) I enclose
- for which (b) I will pay on delivery {cross out line} £.....
- (c) I enclose first deposit of {not applicable}

NAME.....

ADDRESS..... Practical Wireless 24/9/32

# MAKING YOUR RADIO A DE LUXE

By FRANK PRESTON, F.R.A.

An article which explains in simple words how a number of refinements may be made to any receiver.

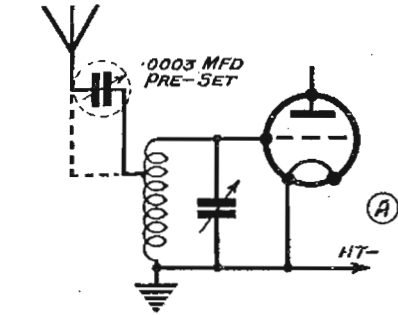

EVERY user of a radio receiver has his own pet ideas regarding the "features" or "extras" which are most desirable, so it would be almost impossible to design any one instrument which would meet exactly the requirements of all listeners. Manufacturers favour the policy of simplifying their sets as much as possible, and therefore reduce the number of knobs or controls to the lowest possible figure. Receivers described in wireless periodicals usually have some refinements and additional controls, but readers often wish to add to these in order to satisfy their own particular fancies. In view of the facts just outlined, it is proposed to show how most of the desirable fitments can be added to any type of receiver in the simplest possible manner. The various additions and modifications will be dealt with briefly under separate headings.

### Volume Controls

Volume controls are perhaps the most popular features of all, and though it is possible to vary the volume of any set by some means or other, many of these latter are unsatisfactory, because they have an effect upon tonal quality as well as upon the volume. Detuning and reduction of high-tension voltage come within the latter category and both are equally bad from the point of view of "quality."

The subject of volume control comes

within two distinct classes. The first is "pre-detector" volume control, which means, of course, that the control precedes the detector valve. This form is the most satisfactory when the receiver is situated near to a broadcasting station, because it prevents overloading of the detector valve and consequent distortion. Four methods of effecting pre-detector control are shown in Fig. 1. At "A" pre-set or variable condenser is inserted in the aerial

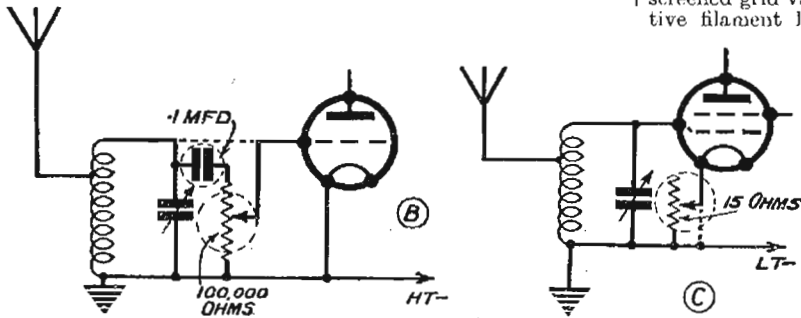
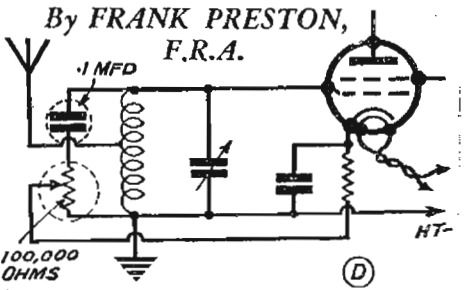

Fig. 1.—Four methods of pre-detector control.

lead; reducing the capacity of this condenser causes a reduction in input to the first valve. This is not a particularly good method, because every time the volume control is adjusted the tuning condenser requires a similar adjustment. It is useful, however, in that it may be applied to any set without alteration to the instrument itself. A much better method is shown at "B," where the connection from the grid of the first valve (either S.G. or detector) to the aerial tuner is broken and taken to the slider of a 100,000-ohm potentiometer wired, in series with a .1 mfd. non-inductive condenser, across the tuner. Volume is varied by rotating the potentiometer knob. As the potentiometer and condenser are in the high frequency portion of the circuit the wiring



to them should be as short and direct as possible.

The control shown at "C" is remarkably simple, but is only applicable when a screen-grid valve is employed. The negative filament lead is removed from L.T. negative and taken instead to one terminal of a 15-ohm rheostat, of which the other terminal is connected to L.T.—. Variation of resistance alters the temperature of the valve filament and at the same time causes a slight variation in grid bias. When A.C. valves are employed we have a wider choice in the way of volume control methods. A system which proves very satisfactory with valves of this type is shown at "D."

A .1 mfd. condenser and a 100,000-ohm potentiometer are wired in series across the aerial tuner, whilst the normal bias resistance is connected to the potentiometer slider instead of to H.T.—. Operation of the potentiometer has a two-fold effect; it increases the grid bias on the S.G. valve and at the same time reduces the effective resistance across the tuner, so lowering the amplification of the S.G. valve and also reducing the input to it. As a result of the combined action the control is perfectly distortionless.

Post-detector volume control is generally easier of accomplishment and more efficient when the set is not so near to a powerful transmitter as to make detector overloading possible; that is, at a distance of not less than about 12 miles. Two forms of post-detector control are shown in Fig. 2. At

(Continued at foot of page 46.)

## DO YOU KNOW?

- That high-frequency currents travel along the surface of conductors, not through them. Therefore all H.F. leads need to be as thick as conveniently may be used—or alternatively of stranded wire.
- That it is possible for the wiring or coils of a receiver to pick up the signals from a near-by powerful station, resulting in difficulty in cutting-out the interference. The remedy in such cases is to screen the coils, or even the complete receiver in very bad cases.
- That hum in an all-mains receiver employing a moving-coil speaker with an excited field can often be traced to interaction between the field of the speaker and the wiring of the set. A metal screen between speaker and receiver, with a good earthed connection, will prevent such trouble.
- That leads from a pick-up in a combined radio-gram should preferably be of the metal-screened variety. By connecting the covering of these leads to earth instability is avoided.

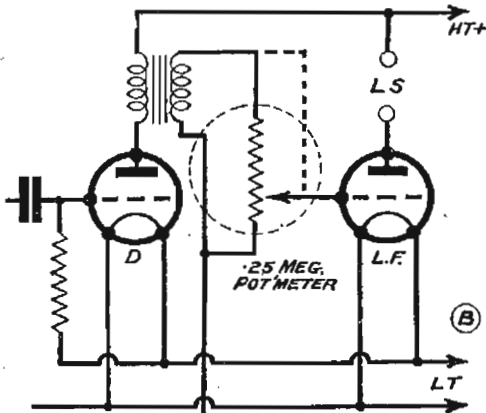
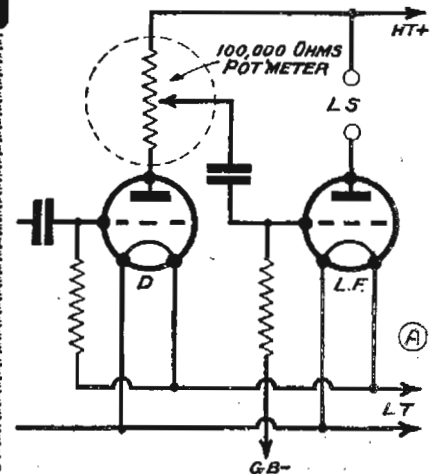

Fig. 2 (and opposite).—Two forms of post-detector control.



THE individual who can boast of even a partial knowledge of wireless usually is called upon to undertake a fair amount of testing work and fault tracing with wireless receivers, both for himself and his friends, and to accomplish this work reliably and efficiently it is necessary to have within easy reach some simple apparatus. There are many devices available, a pair of telephones and a small dry battery being a useful adjunct for many of the tasks.

Another very easily made fault-finder and trouble tracker which I have used on countless occasions employs a neon lamp—one of the simple type so useful as night lights. Anyone having an electric supply laid on in their homes can duplicate the arrangement exactly, and in those cases where such a source is not available, ordinary dry or wet batteries with a total voltage of about 180 will suffice.

**Making the Tester**

One way of making up the tester is to obtain a small D.C. charging set and a pair of new style testing prods. The former consists of a batten lampholder mounted on a small wooden base complete with mains plug and flex, while a pair of terminals are mounted on the base. To these terminals must be connected a length of flex terminating in the testing prods. This simple arrangement is portrayed diagrammatically in Fig. 3, while the photograph, Fig. 2, shows the apparatus complete with the neon lamp. To use it, it is necessary merely to insert the plug in a convenient

**HOW TO MAKE—  
A SIMPLE  
WIRELESS TESTER  
By H.J.B.C.**

insulating sleeve metal prod will be pointed to remain. The arrangement proves very useful when it is to get at the wiring of a wireless receiver for test—see if all the connections are intact. Coils, condensers, resistances, continuity, etc.,

over each enable prod-end visible. The arrangement proves very useful when it is to get at the wiring of a wireless receiver for test—see if all the connections are intact. Coils, condensers, resistances, continuity, etc.,

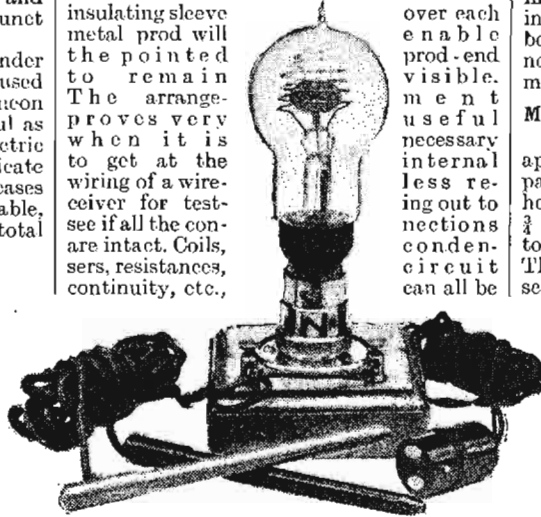

Fig. 2.—This illustration clearly shows the completed wireless tester.

increase until ultimately there is practically a continuous light, this proving that the insulation has broken down and needs replacement. On several occasions insulating material which, on the megger, seemed quite satisfactory, has gradually caused the neon lamp to flicker after a time, whereas if it were perfect no lighting up of the lamp would take place. Another important use is in the tracing of leakage in the insulation of a valveholder, say, between grid and filament. This leakage may not be apparent in the ordinary way, but may still be enough to cause poor results.

**Modified Construction**

If readers prefer, they can make up the apparatus without buying the finished parts by mounting a batten type lampholder on a square piece of wood about 3/4 inch deep and hollowed out underneath to take the two connections to the lamp. Then obtain two pieces of ebonite tubing—see Fig. 1—about 4 inches long and 3/4 inch diameter and screw these internally for about 1 inch. Then turn up on a lathe or file up two brass rods, tapered as shown in Fig. 1, screwing the brass externally for about 1 inch so that the brass screws into the ebonite and is held rigidly. Drill a small hole in each end of the brass rod as indicated and, having bared the insulation from one end of a length of flex, pass an ebonite tube over the end. Thread the bare wire end through the small hole in the rod and solder it with a "blob" of solder dropped in the small channel previously cut away for the purpose.

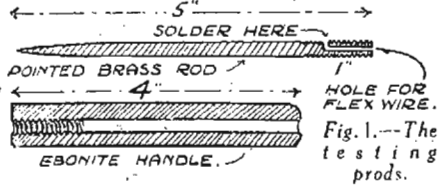

Fig. 1.—The testing prods.

mains socket with the insulated handles held one in each hand, and circuit continuity is then evidenced by the glowing of the lamp. These new handles are quite shock-proof, and finger pressure has to be exerted on the ends to push out the metal prods. If desired, a slight twist of the

examined, and a test of this character is more stringent than the battery and headphones method.

**Using The Tester**

The actual current consumed is only a few milliamperes, but owing to the voltage employed insulating material will sometimes show a leakage which would not be apparent otherwise. In the case of condensers, especially fixed ones, this test proves very searching. If the condenser insulation is imperfect and the test handles are left under the condenser terminals for, say, a couple of minutes, a flicker of light will be noticed in the lamp. With the progress of another few minutes the frequency of the flashes will gradually

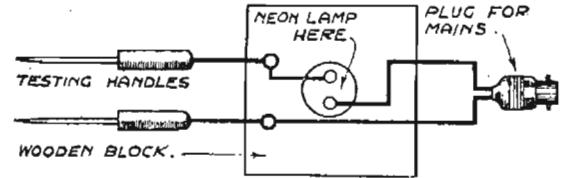
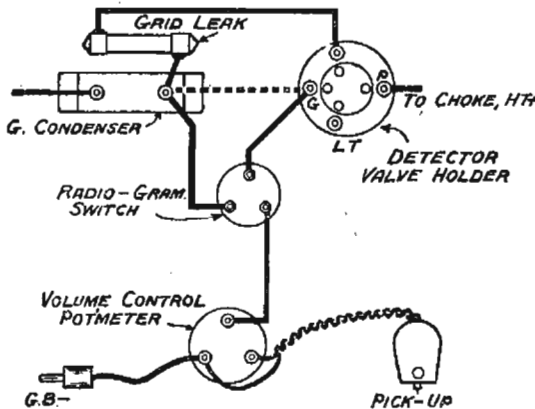

Fig. 3.—Schematic diagram of connections.

The ebonite tube can now be screwed over the rod and the handle is complete. This process must, of course, be duplicated for the other handle, then the pair of free flex ends should be bared of insulation and joined to the appropriate points on the batten lampholder block.

**Making Your Radio a De Luxe—(Continued from page 45.)**

"A" resistance capacity coupling is shown between the detector and low-frequency valves. To fit a splendid volume control it is only necessary to replace the normal



fixed anode resistance by a potentiometer of similar value. The lead from the grid condenser to the "plate" end of the resistance must be disconnected from the latter point and taken to the potentiometer slider instead. As an alternative the grid leak might be replaced by a potentiometer, the anode resistance remaining unchanged.

The grid of the L.F. valve would then be connected to the potentiometer slider instead of one end of the leak. A form of volume control for use with transformer coupling is illustrated at "B." A quarter megohm potentiometer is connected between the transformer secondary terminals (gen-

erally marked either "G" and "G.B." or "O.S." and "I.S."), whilst the connection from the grid to the transformer, shown dotted, is transferred to the potentiometer. Other methods of post-detector volume control are possible but nearly all have a deleterious effect on the reproduction of high notes.

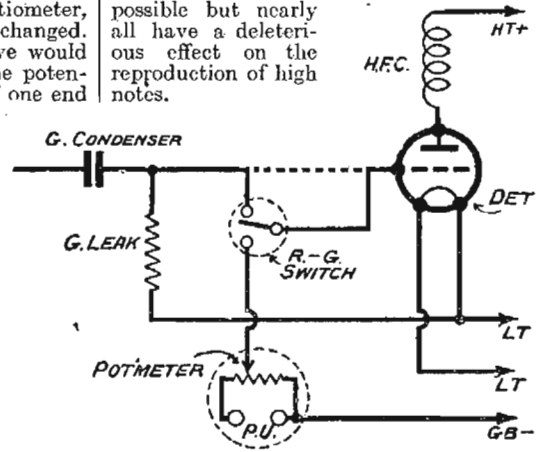

Fig. 3 shows, right, the theoretical circuit, and left, the diagrammatic arrangement of switch and volume control for the pick-up.





**Here is your Opportunity—  
Make Wireless Batteries—It is  
a Paying Proposition.**

**W**HETHER you are a Wireless Enthusiast or not, you know what an enormous demand there is for Wireless Batteries—a demand which is ever increasing by leaps and bounds. If you are a Wireless Enthusiast you know also that you and millions of others are constantly on the look out for BETTER Batteries.

Here is a way in which you can meet the demand for BETTER Batteries and Profit Financially—make them yourself in your Spare time by means of our Patented Method and Formula. By making your own Batteries you can SAVE money—by supplying your friends and others you can MAKE MONEY—and you may make up to £500 a year per licence!

**ANYBODY CAN DO IT!**

**YOU Can Do this:** It has probably never crossed your mind before. You have thought of Batteries as "Technical" things—always regarded them as something "mysterious." The exact opposite is the case. Study the pictures on the left and you will see how really simple it is. You will need no expensive "plant" or machinery—only a few simple tools and hand presses. You need have no special accommodation—a start can be made upon your present Kitchen Table. The Children can help you.

**WE WILL TELL YOU HOW.**

You may know nothing about Wireless or Electricity—it does not matter in the slightest. We will tell you how to do it—FREE. After receiving our instructions you can start right away to Manufacture! And the work is intensely interesting as well as easy—

more fascinating than making your own Wireless Set! The saving is huge—an average worker can complete a 60 volt H.T. Battery in 2 hours at a cost of 2/3 approximately! Compare this with Shop Prices!

**Make Your Friends' Wireless Batteries and MAKE MONEY.**

Consider what this means to you. Not only can you SAVE Money on your own Batteries—and get BETTER Results—but directly your friends know of them they will want some, too! Thus you can begin to build up a profitable Spare-Time Business and reap a Golden Harvest from the Wireless and Electrical Market. Many men are already making comfortable EXTRA incomes in this Pleasant, Easy Way.

There's MONEY in it—big money if you are energetic and anxious to get out of the rut! What could you do with £300 a year?

**PROFITS GUARANTEED.**

Your Market is unrestricted—it can never be overcrowded—you sell where you like and when you like. If necessary, we will purchase sufficient of your

output to guarantee you a weekly Profit, providing it reaches the required standard of efficiency, which is easily attainable. We will continue your training FREE until you reach that standard—that's fair, isn't it?

Don't hesitate—if you have never seen a Battery before you can MAKE money this way. Let us explain this GILT-EDGED, HONEST PROPOSITION fully. Write at ONCE! Make your SPARE Hours—GOLDEN HOURS!

Send this Form for FREE INSTRUCTIONS HOW TO START

**COUPON**

To Mr. V. ENGLAND-RICHARDS, THE ENGLAND-RICHARDS CO., LTD., 242, KING'S LYNN, NORFOLK.

Sir,—Please send me at once, and FREE, full details as to how I can Make Wireless Batteries and Make Money at Home in my spare time. I enclose 2d. stamps for postage.

Print your name and address boldly in capital letters on a plain sheet of paper and pin this coupon to it.

Practical Wireless 24/9/32

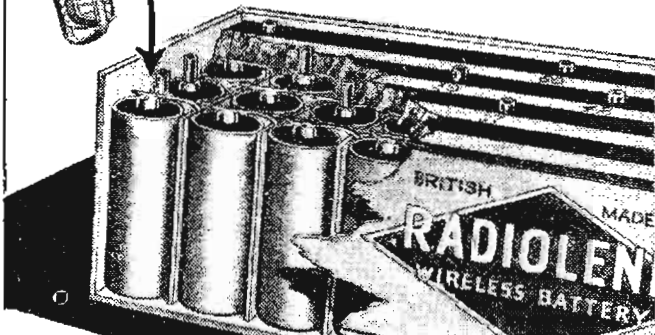

**SAY "T.C.C."—  
for SAFETY**

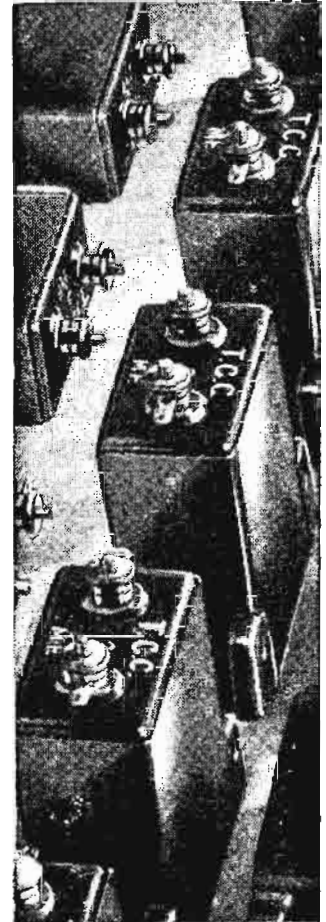

Here are illustrated the 2 mfd. non-inductive type condensers, price 3/10 each. Note the double mounting bracket—a feature of great importance for sub-chassis wiring. Made in capacities from .005 to 2 mfd. Working voltage 200 D.C.

It is simple enough to be sure of absolute reliability in the condensers you buy—just say "T.C.C." and you will get a condenser that is backed by a quarter of a century's specialized research work—a condenser that has won the approval of radio technicians and set designers the world over. . . . Judge for yourself—see the specifications of press receivers—look at the best of commercial sets—you will always find "condensers by T.C.C."

**T.C.C.**  
ALL-BRITISH  
**CONDENSERS**

The Telegraph Condenser Co., Ltd., Wales Farm Road, N. Acton, London, W.1.

From 6<sup>d</sup> . . .  
 . . . to 37/6

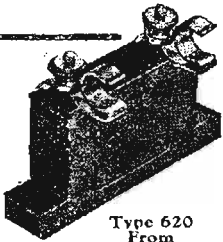

Type 620  
 From  
 1/3 to 3/-



Type 610  
 From  
 1/3 to 3/-

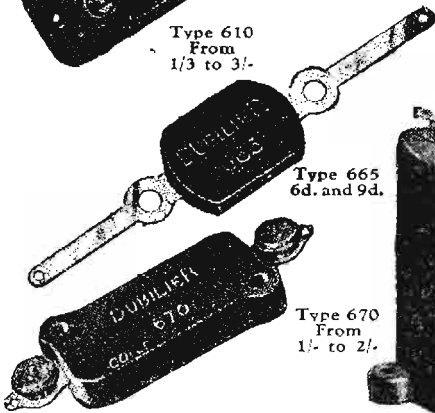

Type 665  
 6d. and 9d.

Type 670  
 From  
 1/- to 2/-

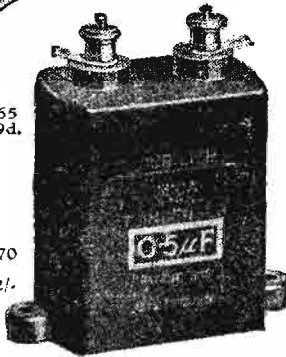

Type B.775  
 From  
 3/- to 37/6



For those who want condensers occupying only a fraction of the space of the ordinary type, yet containing the finest materials and workmanship, there are the Dubilier Types 610, 620, 665 and 670 Mica Condensers for receivers, while for power amplifiers and transmitters there are the Types B770/1/2 and B775/6/7.

No matter whether a Dubilier Condenser is large or small, it is the most up-to-date in design and contains the finest materials it is possible to obtain. On every Dubilier Condenser rests the Dubilier reputation for Dependability. You may be sure that Dubilier will never let you down.

Have you seen the new Dubilier Components Booklet, "Choosing your Condensers and Resistances." Ask your dealer for a copy or write direct to us.

# DUBILIER MICA CONDENSERS

DUBILIER CONDENSER CO. (1925) LTD.  
 Ducon Works, Victoria Road, North Acton, W.3

## FUSE-HOLDERS Programme 1932-33

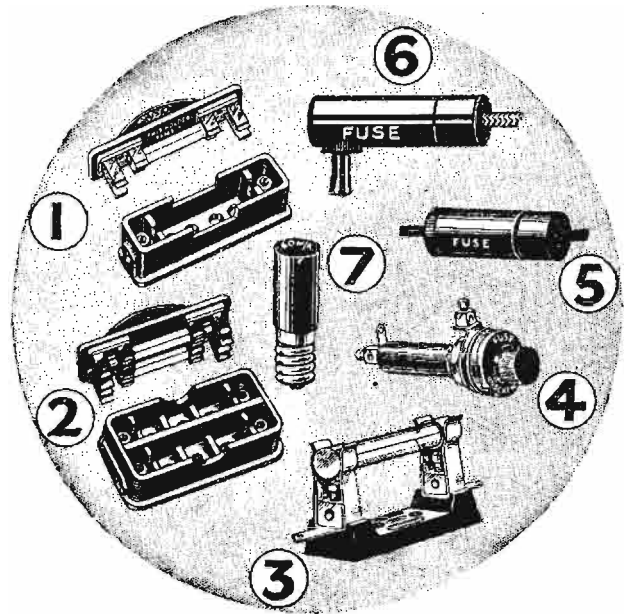

- 1 SINGLE SAFETY BASEBOARD FUSE-HOLDER. Fuse carried on lid, making shocks impossible. Complete with 1 amp. fuse . . . 1/6
  - 2 TWIN SAFETY BASEBOARD FUSE-HOLDER. Fuses carried on lid, rendering shocks impossible. Complete with two 1 amp. fuses. 2/6
  - 3 SINGLE OPEN FUSE-HOLDER. With 1 amp. fuse . . . 9d.
  - 4 PANEL FUSE-HOLDER. For panel mounting. With 1 amp. fuse . . . 1/6
  - 5 FLEX FUSE-HOLDER. With 1 amp. fuse 1/-
  - 6 WANDER-FUSE. With 150 m/a. fuse . . . 1/-
  - 7 "SCRUFUSE." Not bulb, not cartridge, yet both . . . 6d.
- 5 different colour-coded ratings 60 to 750 m/a.

SPARE FUSES---Shown Actual Size..

LONG FUSE. All ratings, 60, 150, 250, 500, 750 m/a., 1 amp., 2 amp., 3 amp. SHORT FUSE. For WANDER-FUSE only, 60, 150 and 500 m/a.

Dealers will fit other ratings in any of these holders at the time of purchase.

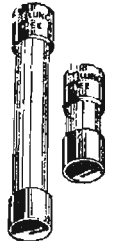

### OTHER BELLING-LEE PRODUCTS.

Set manufacturers, Government Departments, technical experts, the leading Wireless Journals—ALL use and specify Belling-Lee Radio Connections. Make them *your* choice.

A complete range for every requirement, including Insulated Terminals, Terminal Mounts, Plugs and Sockets of every description, Wander Plugs, Battery Cords, S.G. Anode Connectors, Accumulator Connectors, etc., etc.

Write for Complete List

**BELLING-LEE**  
**FOR EVERY RADIO CONNECTION**

Advt. of Belling & Lee, Ltd., Cambridge Arterial Road, Enfield, Middlesex.

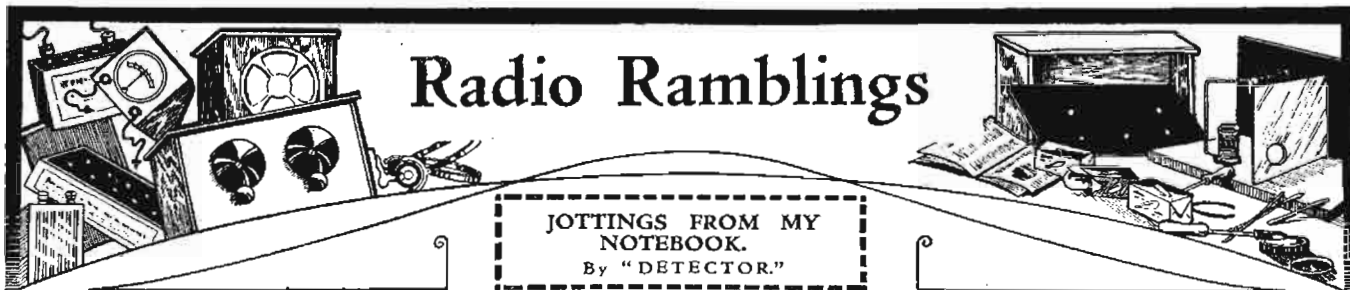

# Radio Ramblings

JOTTINGS FROM MY  
NOTEBOOK.  
By "DETECTOR."

### New West Regional Station.

**D**URING a recent "hike" from Minehead and across Exmoor I made a considerable detour—considerable, that is, if you are walking—to take a look at the new West Regional station in course of erection at Washford Cross. The masts are already up and the station buildings are well on the way, and it is believed that the new station will be on the air early in the New Year. If the masts have anything to do with the efficiency of the station, and there is not much doubt but that they have, the new West Regional will be a signal to be reckoned with. Situated well above sea level, they soar up goodness knows how many feet in the air, and have a peculiar appearance of being most insecure.

### Demand for Selective Sets.

**A**MATEURS in the West Country are already feeling somewhat perturbed as to conditions when the station gets going, and many with sets of doubtful selectivity are looking around for new circuits. A local dealer told me that nowadays nine out of ten customers, when inspecting sets, first of all ask, "Is it selective?" "Will it cut out the local station?" He also told me that in spite of his assurance that certain sets would, it is making business rather difficult. People are somewhat inclined to carry on with their old sets until the new station starts transmitting. Without exception, however, the purchaser of one of the new season's sets of reputable make need have no fear on the score of selectivity: that seems to have been the first thought of manufacturers this year. And the second—well, I think ease of control and *swell* appearance tie pretty closely.

### Fans at Radiolympia.

**I**WONDER what the exact risk figures were that must have been calculated by the Publicity Department of that enterprising valve firm who distributed fans to every "fan" that wanted one during the first few days of Radiolympia. It was a master stroke of publicity and proves that British manufacturers are far more awake than certain people would have us believe. Of course, it might have been cold and wet, we have had Augusts like that, and as the fans must have been printed and made weeks before the exhibition, it was a decided feather in the caps of those responsible. As it was, everybody carried one, and it was so hot that representatives of rival firms had no qualms about giving free publicity to their competitor so long as they managed to keep moderately cool themselves.

### Eliminating Pick-up Capacity.

**T**HE other day a friend asked me to have a look at his new radio-gram he had just completed. It was a splendid job so far as appearances go, but it appeared it was not working as well as the designer

said it would. Signal strength on distant but powerful stations left much to be desired, there was an annoying whistle on certain wavelengths, and reaction was decidedly "ploppy." After some minutes "twiddling," I noticed that the pick-up was switched directly into the grid circuit by means of an alleged low-loss switch inserted in one lead of the pick-up. This was evidently not good practice, for the pick-up wires were connected to two terminals on the baseboard, and attached to the grid circuit was the capacity of the length of wire comprising the pick-up leads, the winding of the pick-up itself, and probably some of the switch and the terminals. Anyway, on disconnecting the pick-up from the two terminals the set immediately started working splendidly, reaction became beautifully smooth, and about 50 per cent. more volume issued from the speaker. I advised my friend to fit a plug-in connector instead of the terminals, and any other reader who is troubled with pick-up capacity might do so as well. It is but the work of a second or two to plug

the connector together when it is desired to listen to records.

### Improving Quality of Pick-ups.

**I**NCIDENTALLY, those readers who use a pick-up in con-

junction with a set utilizing two stages of transformer-coupled L.F., may have noticed that raising the grid bias of the first low-frequency valve when switching over to the pick-up has the effect of improving the quality a great deal. Some pick-ups are particularly critical in this respect, and it is worth trying. A matter of one and a half to three volts makes a great difference and helps to keep down the "blasting" effect of some recordings.

### "Jamming" from Paris.

**T**HE jam around the hefty Poste Parisien station is getting very bad, and as the winter approaches there is not much hope of things improving, and one will need a more than ordinarily selective set for anything like decent reception around the 300 to 350-metre waveband. Even so, there has been some very annoying heterodyne whistles that increase perceptibly about 9 o'clock in the evening just when the News is being broadcast. Readers should watch PRACTICAL WIRELESS for solutions to this problem.

### Predominance of Battery-Operated Sets.

**T**HE figures tabulating the results achieved at the Radio Exhibition make interesting reading, but anybody who was under the impression that battery sets are dying a natural death will have a bit of a jolt when they see that out of 2,000,000 sets sold at Olympia over 1,200,000 of them were battery-operated. It is also interesting and gratifying to learn that over three-quarters of a million more sets were sold this year than last, resulting in some 20,000 more work-people being taken on. The greatest strides, however, have been made in the radio export business, through which Britain has moved up to third place in the world's export market. Over six times the number of foreign buyers visited Olympia this year than in any other year. Altogether it looks like a boom year for the British wireless industry.

### Long-wave Interference.

**I**F you live within twenty miles or so of a medium-wave regional station you have probably been troubled by the programme from that station "breaking through" on the long-wave band, and so interfering with the reception of foreigners. Perhaps the break-through has even been so bad as to spoil the programme of the Daventry National transmitter. This difficulty is often experienced even with receivers which are normally quite selective, and a cure would, therefore, seem to present rather an awkward problem.

(Continued overleaf.)



A SET IN A HAT!

One of the novelties seen at the recent Wireless Exhibition.

**FREE NEXT WEEK!**

Splendid Handbook entitled:  
"All About Tuning and Tuning Coils."

**ORDER YOUR COPY NOW!**

**Radio Ramblings—continued.**

**"Test Voltage" and "Working Voltage."**

**M**OST manufacturers have now abandoned the foolish practice of giving only the "test voltage" of their condensers and instead state the more useful "working voltage." But even this can be misleading, for although the working high tension voltage of a mains set is, say, 250 volts, it does not follow that a condenser having a working voltage of 250 volts is suitable. This is because the actual voltage when the set is first switched on, and for some time after, is probably twice the normal figure. It gradually falls to the normal voltage as the valve heaters reach their working temperature, but until this point is reached there is a negligible load on the high tension supply. When ordering condensers for use in an A.C. set it is thus always wise to specify those having a working voltage twice that of the set. Cheap components of foreign manufacture should be carefully examined whatever voltage is stamped on them, for it is rarely of any significance whatever.

**The New L.F. Coupling Units.**

**T**HERE are now two or three L.F. coupling units on the market which well deserve the favour they are receiving. The units consist of a small transformer, a coupling condenser, and a feed resistance. I need not mention any names because readers will have recognised the components in question. Reasons for their great superiority over ordinary transformers have also been explained. What I want to point out, though, is that ordinary transformers, and cheap ones at that, can be used in

conjunction with a suitable resistance and condenser to give the same effect as the special coupling units. The correct method is to employ a fixed resistance and a fixed condenser. The best value for R depends upon the type of the preceding valve (V), but will generally lie between 20,000 and 60,000 ohms. It should have a resistance of from two to three times the A.C. impedance of V. Thus for a Cossor 210 H.F. (A.C. impedance 20,000 ohms), 50,000 ohms would be just about right; the actual figure is not critical. The capacity of C can be anything from .1 to 2 mfd. but .25 mfd. is a good average value.

**A Nasty Breakdown.**

**O**NLY a few days ago I was asked to look over a home-made A.C. receiver which had suddenly "gone off" after only a few hours' use. When I switched on, the valve heaters were all seen to glow at their normal brightness, but otherwise everything was absolutely dead. There was no click in the speaker when switching on or off, and tests with a milliammeter showed that no H.T. current was flowing to any of the valves. This at once suggested a fault in the high-tension supply circuit, although everything looked O.K. My suspicions were aroused when I saw that most of the fixed condensers were of a cheap, apparently foreign, and nameless type. The only marking on them was "500v." The 4 mfd. condenser connected in shunt with the metal rectifier was removed from the set and tested. As I rather expected, it showed a dead short. But that was only a mild beginning; further investigation showed that the metal rectifier was completely ruined and that

the secondary winding of the mains transformer was burnt out. It was pretty clear what had happened. The condenser, by breaking down, had short-circuited the supply, so putting a tremendous overload

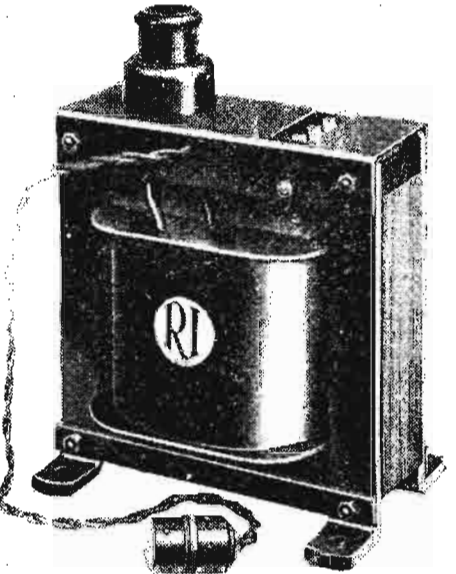

The new R.I. Cinema Projector Transformer referred to on page 58.

on the rectifier and transformer and causing the demise of both. The moral is two-fold. Had a fuse been included in the circuit it would have "blown" and prevented further trouble. But if good quality condensers had been employed the entire trouble would have been avoided.

**Marconiphone "Big-Ben" Loud-speaker.**

**I**N more ways than one we are hearing a lot about the gigantic loud-speaker on top of the Marconiphone offices in Tottenham Court Road, which every quarter of an hour booms out the chimes of Big Ben. You won't need telling that the volume is almost as great as the original; in fact, I think the reproduction was even better than the original!—but I do hope the idea won't spread. Our big cities have enough noise as it is, and some of us would like to forget, now and again, our biggest enemy, Father Time.

**Individual Sets for the Family Circle!**

**A**T a gathering in Birmingham Sir William Morris prophesied that before very long families would be buying "suites" of motor-cars for different members of the family circle, and for different occasions. A tiny "baby" for the "kid brother," a super-sports for the big sister, a large limousine for weddings, funerals, and other ceremonial and concerted family occasions, and so on. The real radio enthusiast has already realized the advantages of such a scheme, and even if his pocket has not allowed him to own a complete "suite" at one and the same time, he has at any rate tried each kind in turn. There is the set for short waves, one for family use—really foolproof, that even Auntie can use—one for long-distance work, and the portable for picnics and outings and for annoying the neighbours in the garden on Sunday afternoons. Even so, human nature being what it is, I am afraid there would still be trouble. Everybody would be wanting to use the same set at once!

**pop a COP on your aerial**

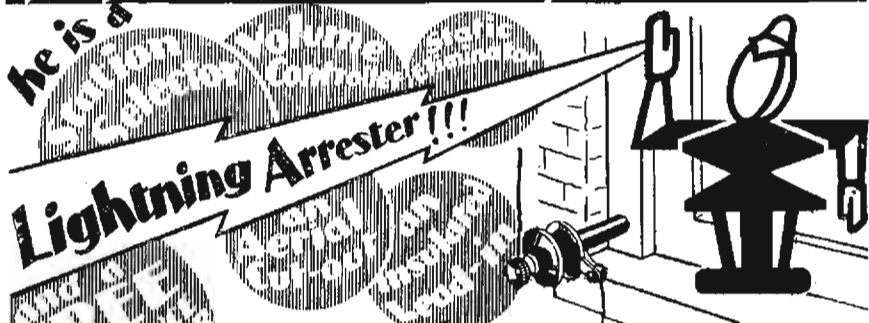

This little fellow is a well-made super LEAD-IN which dispenses with all fiddling selectivity gadgets, lightning protectors, safety switches, wave traps, extra condensers—all these cost money, while a single COP at half a crown will do the work of all and do it properly. Controls volume, cuts out static nuisance, enables you to pick and choose your stations with vastly improved selectivity. Fixed in a few moments! Controlled by a touch of the finger! Adds so much to your pleasure, that you will find the COP the best friend you ever made in the radio world! Get one from your local radio dealer to-day, or send P.O. (postage free) direct to the makers: CLIFFORD R. PRESSLAND (SALES) LTD., 84, Eden Street, Kingston-on-Thames

PRICE  
**2/6**

8-in. size, 2/8  
9-in. size, 3/-  
12-in. size, 3/6

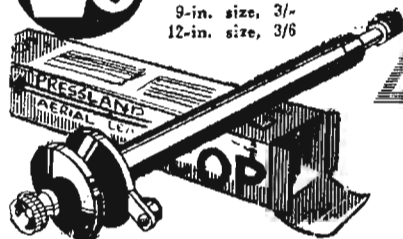

**PRESSLAND**  
**AERIAL CONTROL**  
**COP**  
*Scientific*



# A TRIUMPH OF PRECISION

● Similar in construction to the "NUGANG" Condensers, but the trimmer of front section is operated from the receiver panel by means of a second knob concentric with the main tuning knob. Rigid one piece chassis, very robust construction. Trimmer to each stage. Heavy gauge wide spaced aluminium vanes. Special bearings to rotor ensure permanent accuracy. Capacity .0005.

Matched to within  $\frac{1}{2}$  mmfd. plus  $\frac{1}{2}$  per cent. Complete with disc drive and bakelite escutcheon plate.

2 gang - 18/6      3 gang - 27/-

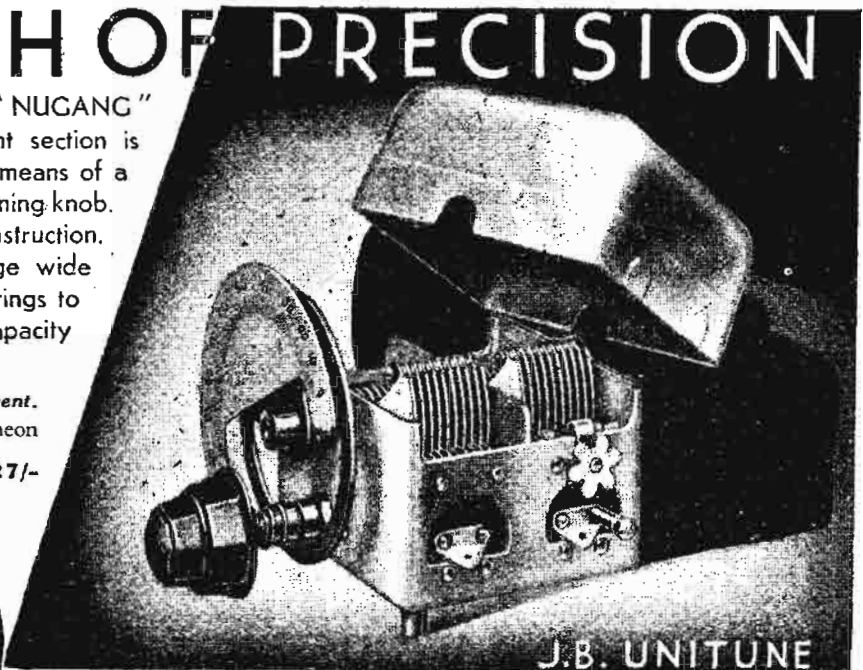

## PRECISION INSTRUMENTS

Advertisement of Jackson Bros., 72, St. Thomas' Street, London, S.E.1.

Telephone: Hop 1837

## The essence of Success— TEAM WORK

To attain perfect efficiency each component must function correctly with its neighbour—they must work together as a team. That is why Formo Dual Range Coils, matched with scientific care, ensure the efficiency you need.

Each Coil, too, has its own distinguishing colour and permanently fixed connecting chart. You cannot go wrong when building or re-wiring your set.

Every Formo Coil you buy is perfectly matched to any Formo variable condenser. That is why the Formo complete band-pass tuner has reached the culminating point in selectivity and sound performance.

Use Formo components always and be sure of perfect results.

### COMPLETE BAND PASS TUNER

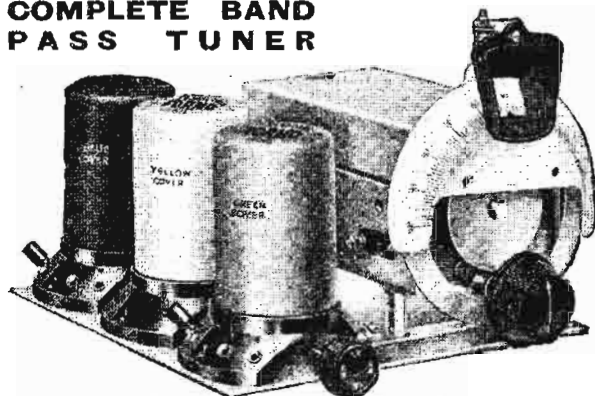

Triple Gang complete with Aerial and pair of Band Pass Coils, mounted on aluminium base. Perfectly matched and all switches ganged, **46/6**

Dual Gang with pair of Dual Range Coils (Aerial and H.F.) similarly matched and mounted, **33/6**



### FORMO DUAL RANGE COILS

Formo Dual Range Coils, Aerial, H.F., First and Second Band Pass,

Pair of matched Aerial and H.F. Coils, mounted on aluminium base with ganged switching, **16/-**

Pair of Band Pass Coils and H.F. Coil, similarly mounted with ganged switching, **23/6**

**7/6**  
EACH.

## YOU NEED



If you cannot obtain Formo components locally, send the name of your radio dealer to:—

# The FORMO CO.

Crown Works, Regents Park, Southampton.

London: 23, Golden Square, Piccadilly, W.1.

# HOW TO PLACE YOUR COMPONENTS

Badly-placed components are frequently the cause of poor reception, often giving rise to interaction.

This article by "Ingot" tells you what pitfalls to avoid and how to avoid them.

THE actual placing of components in a receiver is of great importance, far greater than the majority of constructors realise: a sound circuit and good, well-chosen components are two features that go to make an efficient receiver, but if they are badly arranged the results are often disappointing, while in some cases the constructor is rewarded by a piercing howl.

Some years ago a noted wireless authority, in describing a set, wrote "Keep all wires very short and space the components wide apart." While this advice indicates the

ance, which is positioned in the same place, the far end being connected to the H.T. lead, which runs to a convenient place for fitting the terminals in one place and indicating them in the other. Another point which would escape the attention of many is that the grid condenser and leak are shown very close indeed to the grid of the valve (see Fig. 1). In actual practice it is vitally important that the leads between the grid condenser, leak and valve, should be reduced to the absolute minimum. A further examination of the two drawings will show that the position of components in theoretical and practical diagrams are the same with one notable exception, which is the reaction condenser, which has unavoidably to be brought to the front panel; this to some extent strengthens the argument, as it will be more desirable to place the reaction condenser in the position indicated on the circuit diagram and control it by means of an extension handle; this is, however, not necessary in general practice, but it is interesting to note that such an arrangement is adopted in quite a number of commercial receivers.

coil with a dotted line, which will also indicate the position that the coil should occupy on the baseboard.

The only deviation that is usually necessary when planning the baseboard from the theoretical diagram is brought about by the use of a ganged condenser, in which case the various sections will be in very close proximity to each other and not spaced as the diagram will indicate: this is done for clearness, but it need not cause the constructor undue worry, as the rest of the components can be mounted in the usual way, and the coils will usually be in a convenient position for connecting to the condenser, provided that the former are not placed too far apart. This figure is, however, usually controlled by the length of the ganging rods which link up the switches which are, with few exceptions, located in the coil base. It may be mentioned in passing that it is not always desirable to have switches in the coil base, as the blades occasionally require cleaning, which is a difficult matter when they are inaccessibly placed.

Another type of construction which is of late gaining in popularity is all-metal chassis-building, which is full of many obvious advantages and will save the constructor spending many weary hours trying to trace the cause of strange motor boating and instability; with a blue print of a correctly-designed all-metal set, this point, naturally, does not arise.

### Pitfalls to Avoid

The chief snag to be avoided is the use of "motor bus" returns, which is the name given to the practice of connecting to the nearest point of the chassis any lead that has to go to earth. Such an arrangement is liable to cause trouble as, unless the components are positioned with great accuracy and foresight, stray currents flowing over the chassis set up an assortment of stray fields which may be so placed that they make the set violently unstable; the reader will be aware that a current of electricity flowing through a conductor always sets up a magnetic field around the material through which it is passing. It is not the intention of the writer to condemn the use of a metal chassis, but rather to

(Continued on page 54.)

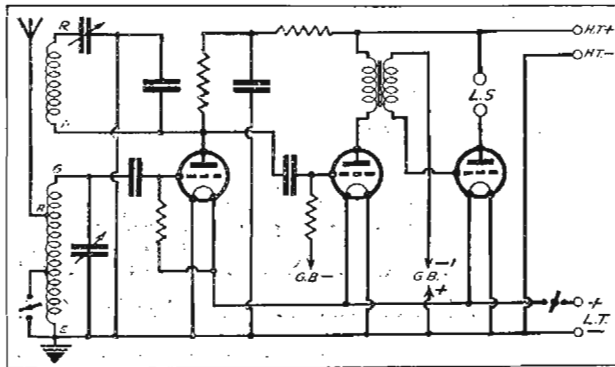

Fig. 1. Note the similar positioning of the symbols above to the position of components on the practical drawing Fig. 2 below.

ideal state, it is unfortunately not possible to place two objects wide apart and join them with a short piece of wire. The planning of a receiver can be grouped into two headings, (1) the actual placing of the components themselves, and (2) the wiring; the former is, perhaps, of major importance, as it will determine to some extent the actual course that the latter will have to follow.

The theoretical circuit is primarily intended, of course, to indicate the nature of the components used and the connections between them, but though few people realise it, a general idea can be gained of the best layout from a study of this diagram. The reason for this is that a skilled designer naturally endeavours to make a diagram as clear as possible to those who read it, with the result that components are arranged in a drawing so that those connected together are placed near each other, which is exactly the state of affairs that should exist in a receiver.

Take, for example, the diagram shown at Fig. 1, and compare it with the practical diagram shown at Fig. 2. Many points of resemblance are apparent; the aerial terminal is in the top left-hand corner in both diagrams, the aerial tuning coil is similarly on the extreme left-hand side with the tuning coil next to it, the only difference being that the condenser in Fig. 2 has been drawn towards the panel for obvious reasons. Continuing a study of Fig. 1 we find that the next item is the valve, which is placed in an exactly similar position in Fig. 2, except, of course, the actual valve holder is shown in place of the symbol of the valve; continuing this comparison, it will be seen that the anode valve leg is connected to the anode resist-

### Screened Grid Receivers

A receiver employing one or more screened grid valves is more difficult to arrange, but the theoretical diagram often gives an even better idea of baseboard layout, as in types requiring a sheet metal screen it is usual to indicate by either a thick or broken line where this screen is placed and consequently which components go on the aerial side, and which on the anode side. When the screened grid valve is actually mounted through a hole in the screen, it is usual to indicate this by allowing the valve to break the screen in the manner shown at Fig. 3. Similarly, when coils of the canned type are intended by the designer, it is usual to indicate it by surrounding the

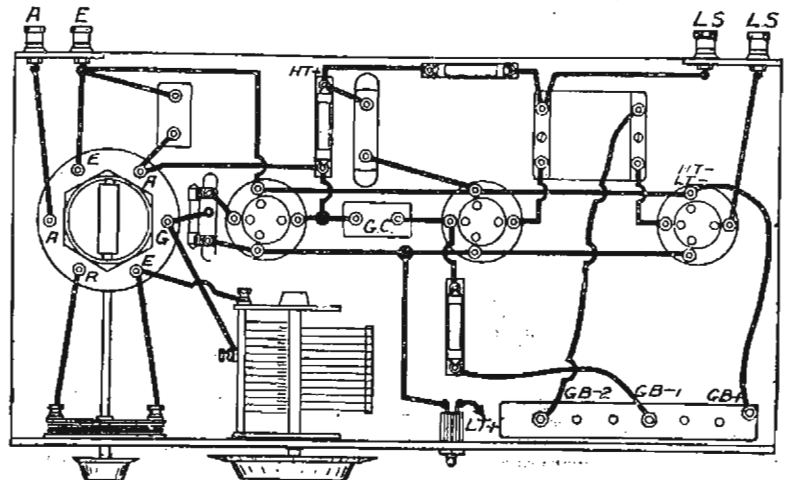
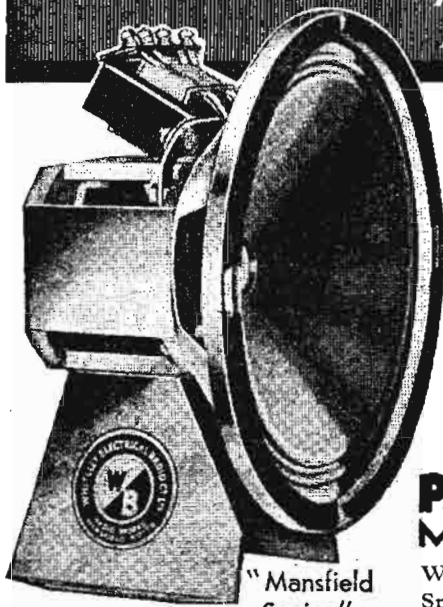

Fig. 2. The practical layout of the circuit shown at Fig. 1 above.

**THEY COMPLETELY CAPTURED**  
*"Radiolympia"*



"Mansfield Senior"

(The Improved P.M.4.)

**42/-**

COMPLETE with 3-ratio transformer

The new



**"MANSFIELD"**

**PERMANENT MAGNET Moving-Coil Speakers**

Write NOW for the art booklet, "Speaking of Speakers," giving full information on all the new W.B. moving-coil speakers. W.B. always have been Pioneers and Leaders in this field. Makers also of the famous valveholders, switches and the new Mansfield Kit—the only Kit with a moving-coil speaker. Ask also for special leaflet of Mansfield 3-v. M.C. kit.

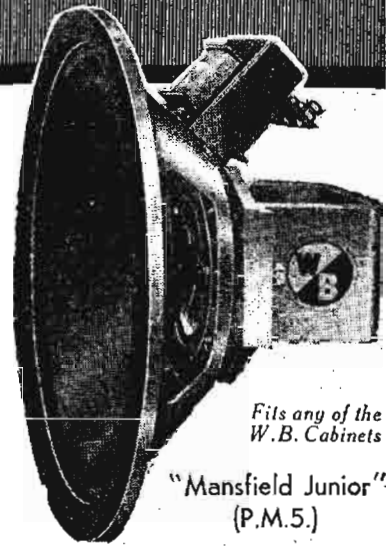

Fits any of the W.B. Cabinets

"Mansfield Junior" (P.M.5.)

**27/6**

COMPLETE with 3-ratio transformer

Note: The prices of W.B. valveholders and switches HAVE NOT BEEN RAISED. The world-famous quality, precision and reliability is higher than ever. They are used to-day in all the leading experimental laboratories in Britain.

Whiteley Electrical Radio Co., Ltd., Radio Works, Mansfield, Notts.

Irish Free State Distributors: Kelly & Shiel, Ltd., 47, Fleet Street, Dublin.

**BY SPECIAL REQUEST!**

At the special request of "PRACTICAL WIRELESS" we have produced this original and exclusive design of Cabinet for the "DOLPHIN THREE."

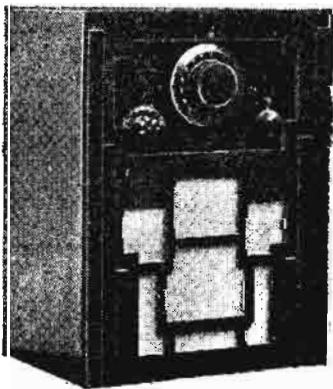

"CLARION" CABINET for the "DOLPHIN THREE"

This modern and attractive cabinet is exceptionally well made from selected Oak and is supplied with a strong Chassis for supporting baseboard and speaker. Ample room for batteries. Provision is made for frame aerial windings.

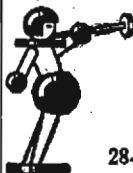

We take this opportunity of wishing every success to all readers of "Practical Wireless" and are ready to help them by promptly supplying all their cabinet needs.

**CLARION**  
Radio Furniture

28-38 Mansford St., London, E.2.

CABINET 19/9  
 CHASSIS 7/6  
 Carriage Paid

**FREE BLUEPRINT WITH THIS NEW DUAL-RANGE COIL**



Sovereign Dual-Range Coil (Type W.S.) with free blue-print 3/6

With every Sovereign Dual-Range Coil, Type W.S., a blue-print will be given (free) showing how to build the Sovereign "Viceroy" and Sovereign "Ambassador" Sets. This wonderful coil is made to an extremely high level of efficiency, functioning perfectly on both wave-bands. It is accurately wound on bakelite with numbered terminals and mounting lugs on the base, and can be thoroughly recommended wherever a Dual-Range Coil is used. Let us know if your dealer cannot supply you with this or any other Sovereign Components you require.



Readers of "Practical Wireless" should make certain they know about the complete range of Sovereign Products—long famous for their quality and low prices. A postcard to us with your name and address (Dept. Pr. W.), will bring you a free copy of the Sovereign 1933 Components Catalogue. Do as the experts do—use Sovereign wherever you can.

SOVEREIGN PRODUCTS, LTD. SOVEREIGN HOUSE, ROSEBERY AVENUE, E.C.1.

### How to Place Your Components

(Continued from page 52)

suggest that wires coming from a source where high frequency current is flowing should be connected by means of a piece of wire straight to earth if this is their correct destination. It is a common mistake when building a mains set to connect wires to earth that should be connected to cathode, for example, the condenser connected to the screening grid of the valve to earth instead of cathode, and similarly to connect the earth end of a choke fed loud-speaker to earth instead of cathode; when a pentode is used, such a procedure would often result in a considerable loss of bass. The chassis can profitably be used to carry one side of the low tension accumulator to the valves, and it is usually quite in order to connect H.T. — and G.B. + to the chassis, and such things as decoupling and H.T. by-pass condensers.

#### Earthing the Coil Cans

Generally speaking, the coil cans can be earthed by bolting them to the chassis, but cases have been known when stability is only possible when the tuned grid coil can is insulated from the chassis, and taken direct to the earth terminal. Baseboard planning is of vital importance, but the constructor should find little difficulty in arranging the components correctly if the theoretical diagram is carefully followed in the manner indicated above and deviations used only where necessary, such as the mounting of variable components on the panel and the bodily twisting round of the H.F. end, when a ganged condenser is employed that is so constructed that each

section lays behind the other from back to front. This arrangement follows the same principles, because the relative position of the different components is adhered to, the only variation being that the H.F. end is at right angles to the detector and output valve layout.

aerial terminal is at the left-hand side of the set and L.S. terminals at the right, endeavour to arrange the set in such a position that the lead-in comes from the left, and does not pass near L.S. leads, as it is possible to get instability from this practice. For the same reason, batteries

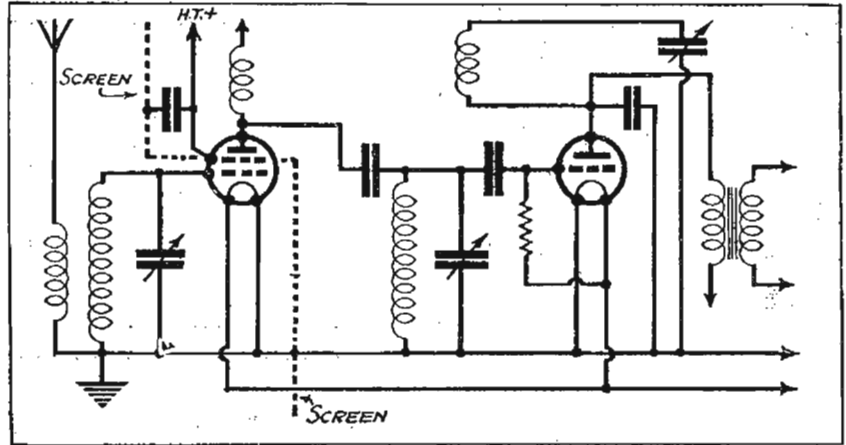

Fig. 3. The valve through the screen shows clearly which components must be to the left of the screen and vice versa.

In addition to the placing of the actual components there is, of course, the question of placing external leads and components. Unfortunately, the disposition of aerial, earth, and loud-speaker terminals will enforce the connections at those points, but where possible these leads should not pass each other. That is, if the

which are at earth potential, should not be placed in such a position that the leads to them are permitted to trail near H.F. coils or leads on the H.F. side of a receiver.

Careful attention to all the points mentioned in this article will result in getting that little extra from the set.

## From the NEW

# WEARITE

## BOOKLET!

**BEFORE** you start building *any* set get the NEW Wearite Booklet! Whether it is Coils, Resistances, Chokes, Transformers, Switches, or components of special design, consult this illustrated booklet first. Every component listed in it is built up of years of experience of the needs of the constructor. Each and every product has the stamp of efficiency on it—'WEARITE.' Remember Wearite was the first name in Radio Components—and is still first to-day.

● **SEND FOR YOUR COPY NOW!**

Wearite will solve your technical difficulties. Write to "Research Dept." if you have a problem.

**WEARITE PARTS REQUIRED FOR THE "LONG RANGE EXPRESS" and "DOLPHIN STRAIGHT 3"**

Q.V.C. 50,000 ohms . . . . .	4/6
G.W.C. Switch . . . . .	1/3
H.F.P. Choke . . . . .	3/6
H.F.P.A. Choke with armoured pigtails . . . . .	4/-
H.T.16 Smoothing Choke 10/-	
2G.42 Switches complete with brackets and linking arrangement . . . . .	5/-
1 metal screen and chassis with all holes, as per specification . . . . .	6/9

**WRIGHT & WEAIRE Ltd.,**  
 740, HIGH ROAD, TOTTENHAM, N.17  
Tel.: Tottenham 3847/8 and 3015.



# CLIX

FOR PERFECT CONTACT

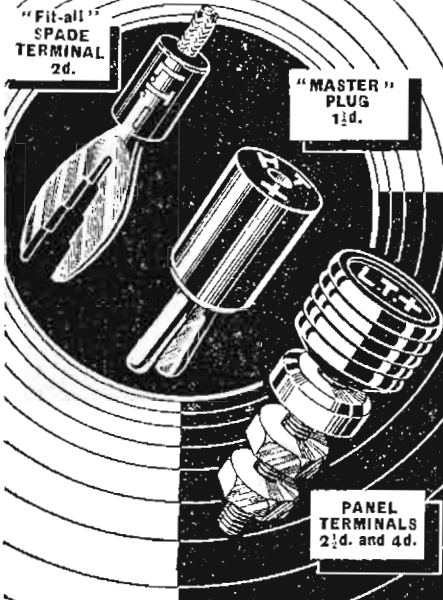

"Fit-all" SPADE TERMINAL 2d.

"MASTER" PLUG 1½d.

PANEL TERMINALS 2½d. and 4d.

"CLIX" SPADES, WANDER PLUGS, PANEL TERMINALS—SPECIFIED FOR THE LONG RANGE and DOLPHIN EXPRESS THREE and STRAIGHT THREE See "CLIX" Advt. on page 55, and write for fully illustrated Folder "A" Lectro Linc Ltd., 254 Vauxhall Bridge Rd., S.W.1

## PROTECT YOUR VALVES FROM ACCIDENTAL SHORT-CIRCUITING

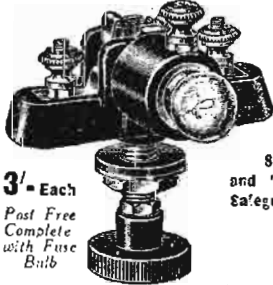

BY FITTING THE "BUSCO" FUSE SWITCH

All "BUSCO" Switches have Self-cleaning Contacts and "Set Cracking" is safeguarded through the Vice-like Grip at Contact Points.

3/- Each Post Free Complete with Fuse Bulb

BUSBY & Co., Ltd., Price St., BIRMINGHAM.

## GUARANTEED KITS for all "PRACTICAL WIRELESS" SETS

Prices on application. Approved Kit suppliers for all "Hobbies" sets.  
 "HOBBIES" "Autokoil" All-wave Two... £2. 5. 4  
 " " "Autokoil" Reinartz Three... £3. 9. 4  
 " " "Long Distance Four" .. £4. 0. 6  
 "AMATEUR WIRELESS"  
 "Ten Station Two" .. £2. 1. 0  
 "DAILY EXPRESS" "All-wave Two" .. £2. 6. 6  
 All valves and batteries extra. Kits supplied on Easy Terms.  
 "AUTOKOIL ALL-WAVE TUNER," 200-2,000 metres, 12s. 6d.  
 Free Circuits with every tuner. LIST "P.R." FREE.  
**A. W. HAMBLING, LTD.,** 16, Alfred Place, London, W.C.1.

## RELIABILITY WIRELESS GUIDE

Write NOW for FREE copy of new edition which contains full details of New Season's Apparatus, Components etc. Also ask for latest Bargain Bulletin. Any material advertised in "Practical Wireless" can be supplied:—  
**J. H. TAYLOR & CO.,** 29, Radio House, MACAULAY STREET, HUDDERSFIELD, Phone 341.

# BUILD IT YOURSELF - with a PILOT AUTHOR KIT



PILOT AUTHOR KITS

ENSURE 100% SUCCESS . . .

. . . EXACT TO SPECIFICATION

IN SEALED CARTON From all Dealers



## EXCLUSIVE FEATURES OF PILOT AUTHOR KITS

- Contains parts only as chosen and solely specified by the Author.
- Officially approved therefore by Authorities you can trust implicitly.
- Complete, down to the last screw and piece of wire.
- The only Kit of Parts that guarantee strict adherence to Author's solely specified components and enable the Author's published set to be duplicated in every way.
- All panels and terminal strips accurately drilled and slotted to specification.

## GOOD NEWS FOR CONSTRUCTORS

BY special arrangement with the Editor of "Practical Wireless" PILOT AUTHOR KITS—famous throughout the World for strict adherence to Author's first specification—are available from your usual Dealer in the familiar sealed carton. You are saved therefore the delay, trouble and difficulties experienced in collecting the specified items essential towards building a Set an absolute duplicate of that designed by the Author. **Build a Pilot Author Kit—there is no substitute.**

### LONG RANGE EXPRESS 3

Complete PILOT AUTHOR KIT comprising all parts as specified, with ready-drilled Panel and Chassis, but excluding valves and cabinet.

### DOLPHIN STRAIGHT 3

Complete PILOT AUTHOR KIT comprising all parts as specified, with ready-drilled Panel, but excluding valves and cabinet.

£5 - 11 - 6      £3 - 7 - 6

## DEMAND A PILOT AUTHOR KIT

BRITISH **RADIOGRAM**

In cases of difficulty, write direct, giving name and address of your nearest Dealer.

Advertisement of **THE BRITISH RADIOGRAMOPHONE CO. LTD.,** PILOT HOUSE, CHURCH ST., LONDON, N.16  
 Telephone: Clissold 6287/8.

# Amazing Offer to Readers

## NEWNES WIRELESS CONSTRUCTORS' ENCYCLOPÆDIA

This amazing encyclopædia is offered to all readers of PRACTICAL WIRELESS to commemorate the publication of the first number. The entire contents, written and edited by the most accomplished designers and writers on the practical side of wireless construction, are presented in a new and attractive manner. The whole field of wireless construction is covered by its pages, and the volume is remarkable for the number of practical diagrams used to illustrate the text.

You will find everything in this volume, no matter in which branch of radio you are interested. The wonderfully complete contents are arranged in encyclopædic order, so that you can turn up the information you require merely by following the alphabetical arrangement. You cannot afford to be without this unique volume. It contains everything you need to know, from accumula-

Value  
**8/6**

tors and aerials to X-rays and zero capacity. There are hundreds of practical circuits, wiring diagrams, and lay-outs, comprehensive information on soldering and wiring, transmitting, eddi-currents, condensers, coils, and loud-speakers. It tells you how to operate a set, how to diagnose receiver troubles, how to design and make short-wave receivers, how to erect an aerial, how to add an amplifier, how to make superheterodyne receivers and how to understand your valves, how to make coils and cabinets, how to choose components, all about electrical units, accumulator charging; all about potentiometers, variable condensers, valve curves, switches, and every other branch of wireless construction. Wireless terms and definitions are explained in concise and clear language. Every wireless enthusiast will find this volume a treasury of knowledge.

Id. Stamp  
must be  
affixed here.

Name .....

Street .....

Town & County .....

**1** POST THIS TO  
**PRACTICAL WIRELESS**  
Presentation Department,  
39, King Street, Covent Garden,  
London, W.C.2.  
**TO - DAY**

In accordance with the conditions of your special offer please send me a SUBSCRIPTION VOUCHER on which to qualify for my Presentation Encyclopædia. I have asked my Newsagent to deliver PRACTICAL WIRELESS regularly every week.

Reader's Name .....

Full Address .....

Newsagent .....

Address .....

Leave blank.

Reader's Signature .....

Fill in this form and the label on left in Block Letters. Stamp the label as directed and post both of them in an unsealed envelope (id. stamp only required) to—  
PRACTICAL WIRELESS Presentation Department,  
39, King Street, Covent Garden, London, W.C.2.

**2** If you have NOT placed a standing order with your Newsagent for the regular delivery of PRACTICAL WIRELESS, hand him the order form below without delay.

**PRACTICAL WIRELESS**  
**ORDER FORM**  
For Newsagent

To .....

(Newsagent)

Address .....

Please deliver (or reserve) PRACTICAL WIRELESS for me weekly until further notice.

Name .....

Address .....

Date .....

PLEASE WRITE IN CAPITAL LETTERS.

TO AVOID DISAPPOINTMENT, ACT NOW 

# of "Practical Wireless"

## How to obtain this Presentation Volume

**FIRST** read the conditions below. Complete and post to PRACTICAL WIRELESS Form No. 1, together with address label on left (to which a half-penny stamp must be affixed, and your name and address filled in). If you have not already placed a regular order for PRACTICAL WIRELESS, fill in Form No. 2, and hand it in to your Newsagent immediately. On receipt of Form No. 1 and the address label, we will send you a special Subscription Voucher on which to qualify for your Presentation copy of Newnes' Wireless Constructors' Encyclopaedia. Your volume will be reserved for you, and will be despatched immediately we receive the completed Subscription Voucher.

**IMPORTANT.**

*It is not possible to buy this wonderful work—it can only be obtained by regular readers of PRACTICAL WIRELESS. The closing date is Wednesday, October 12th, and so that there is no possibility of your being disappointed, be sure to fill in the forms TO-DAY.*

**READ THESE  
SIMPLE  
CONDITIONS**

Affix to the Subscription Voucher which we post to you 13 Gift Stamps cut from the bottom left-hand corner of the back page of PRACTICAL WIRELESS for 13 consecutive weeks commencing with the next issue.

When your Subscription Voucher is complete, send it, together with a Postal Order for 2s. 4d., to cover registration, postage, packing, insurance, etc., to PRACTICAL WIRELESS Presentation Department, and your copy of Newnes' Wireless Constructors' Encyclopaedia will be despatched to you immediately.

No reader may qualify for more than one copy of Newnes' Wireless Constructors' Encyclopaedia.

This offer applies to persons residing in Great Britain and Ireland. Readers in the Irish Free State must pay any duty imposed.

The last day upon which reservation forms will be accepted is Wednesday, October 12th.



# A CHAT ABOUT THE LATEST COMPONENTS

**FILT.**  
**"THE strength of a chain is in its weakest link!"**  
 The earth connection of a receiver is too often neglected, a failing which results not only in weaker signals, but, with some types of receiver, often leads to instability. Messrs. Graham Farish are marketing a chemical compound in a copper container which is intended to be buried in close proximity to the earth rod or other earthing device. The chemical then spreads through the earth, attracting moisture and thereby ensuring a perfect low resistance earth, resulting in increased range and stability. At a cost of 2s. 6d. this is a valuable accessory which no enthusiastic listener can afford to forego.

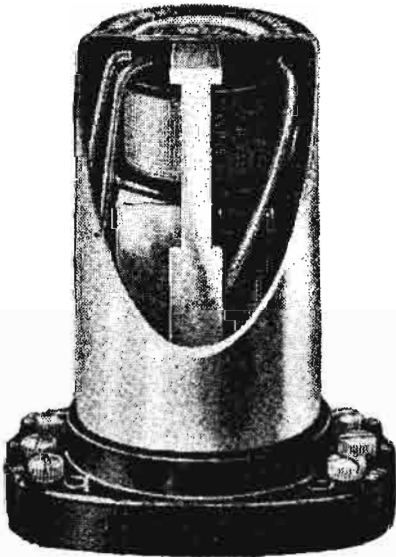

The Benjamin Transfeeda, a Unique L.F. Coupling Device.

**BENJAMIN TRANSFEEDA.**  
 This parallel-fed method of connecting L.F. Transformers has a great deal to recommend it. The resistance in the anode circuit may be chosen to more nearly match the impedance of the valve than the primary of a transformer, and the avoidance of the D.C. current flowing through the transformer primary results in more even amplification and removes the liability of breakdown. The Benjamin Transfeeda consists of a high-class transformer, having an inductance of over 80 Henries, and a wire-wound resistance tapped to give two values, 30,000 ohms and 50,000 ohms. This resistance is rated at 1½ watts. A metal-cased condenser completes the unit, and the whole is contained in a neat, shielded case only 3in. high with a base 2in. x 2-11/16in. On test the unit gave a wonderful response—sensibly straight from below 50 to 5,000 cycles. The price is only 11s. 6d. and we have no hesitation in recommending this component to our readers.

**VARLEY RECTATONE TRANSFORMER.**  
 ULTRA-SELECTIVE tuning circuits; bad wiring on the H.F. side, and some other arrangements, tend to give a cut-off of the higher notes in the musical scale. It is, in fact, sometimes desirable to obtain extreme selectivity even at the expense of high notes and rely upon tone correction in the L.F. stages. The Rectatone Transformer, manufactured by Messrs. Varley, Ltd., is a L.F. transformer designed to give even amplification from 50 to 1,000 cycles from which point the characteristic rises, the peak being at 4,000 cycles. To employ the transformer for this purpose, an additional resistance of 2,000 to 3,000 ohms is necessary, and a further valuable feature of the component is that by omitting a link between two terminals the transformer gives a straight line characteristic and acts as an ordinary transformer. The price of this inter-

esting component is only 15s., and will prove a valuable accessory for the experimenter.

**"SILVER KNIGHT" H.T. BATTERIES.**  
 A NEW H.T. battery is making its appearance on the market under the name "Silver Knight." Manufactured at Silvertown by the India Rubber, Gutta Percha and Telegraph Works Co., Ltd., these batteries are entirely British, and the chemicals used in them are thoroughly tested out in their own chemical laboratory before use, in addition to the complete battery. The makers claim that no faulty cell can find its way into a battery, and the waterproof casing and insulation provided ensure a thoroughly sound battery reaching the customer. The batteries are made in standard and triple capacities, rated at 6 and 15 m.a. discharge rates respectively. A 9-volt grid battery is also included in the range.

**"GILBERT" RADIO SERVICE TOOL.**  
 A TUBULAR spanner accommodating a 2BA nut at one end and a 4BA at the other; a ¼in. blade screw-driver, and a ¼in. screw-driver recessed to take slotted terminals. These articles are combined in one tubular casing provided with a fountain pen clip so that the tool may be conveniently carried in the pocket. A 6BA nut may be adjusted by reversing the recessed screw-driver and inserting it in the outer container. This is a very valuable little tool for the amateur constructor and, with a nickel-plated finish, costs only 2s. 6d.

**CINEMA PROJECTOR TRANSFORMER.**  
 THE firm of Radio Instruments are well known as makers of L.F. transformers, and a new component recently introduced by them is the cinema projector transformer. This is designed to be used with the well-known home cinemas which are on sale in this country but which are made abroad and consequently designed to operate at 100 volts or so. It is usual to employ a wire-wound resistance when connected to mains of higher voltage, and as users of this apparatus have no doubt experienced, quite a large amount of heat is radiated by the voltage-dropping resistance. The new transformer will therefore be found to be a useful substitute for the resistance, and being furnished with a protected plug, will be quite safe to handle. Two models are manufactured, both suitable for mains voltages of 200-250, but one giving a 300 watt output, and the other a 600 watt output. The price is £2 10s. and £4 10s. respectively.

**EELIX CONNECTORS.**  
 THE home constructor who does a lot of experimenting will have often felt the need for an easy, quickly made-up connection. The Eelix terminals will be found to be very useful for this purpose, as they are very plainly identified with a readily exchangeable name-plate, and will accommodate four or five different types of connection at once—being a plug and socket; normal type pillar terminal; or pin-type terminal; and will take a soldered connection or the square section wire in a slot at the base. Various types of coloured plug are manufactured to plug into these terminals, and, in addition, Messrs. J. J. Eastick and Sons also manufacture a complete range of plugs, sockets, switches, etc. The terminal mentioned above is sold at 4d.

**CLARION PICK-UP.**  
 THE British Clarion Co. Ltd. have sent us the Clarion Pick-up, which is of rather unique design. Unlike the majority of pick-up arms, this requires no rest to be attached to the motor board, but is provided with a stop so that the needle only just goes below the level of the turntable surface. The whole is finished in bakelite—the tracking error is less than 1½ degs.—and with adjustable damping this component presents good value at 21s.

**"WEARITE" HETERODYNE FILTER.**  
 RECEPTION of the foreign and even local stations is often spoilt by heterodyne whistles and mush, particularly when using a powerful receiver. This may be overcome by the use of the "Wearite" heterodyne filter, which cuts out the heterodyne whistle without affecting the quality. The filter is designed to give a very sharp cut-off at a certain frequency, leaving the reproduction below that frequency unaltered. The

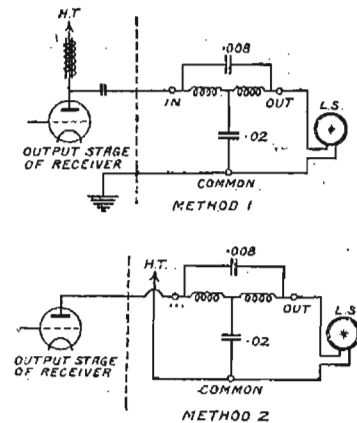

Two methods of incorporating the new Wearite Heterodyne Filter.

filter is therefore specially superior to simpler and cheaper forms which can only eliminate the undesired whistle at the expense of quality. Two models are made, one cutting off at 3,500 and the other at 5,000 cycles per second. The price for either type is 10s. 6d.

**PILOT KITS**  
 SINCE the early days of broadcasting the famous firm of Peto Scott, Ltd., have adopted the policy of supplying and recommending one make of component only for the constructor to use in making up a receiver—a policy which readers will observe is being adopted in this journal. Under the name of Keystone, Messrs. Peto Scott had marketed complete kits for most of the receivers described by our contemporaries, and readers may purchase from this reputable firm complete kits for the construction of the sets described by us. This method of purchasing the various component parts saves a great deal of trouble, and one is assured of getting all the parts at one time, so that construction may be proceeded with without delay.

**COLVERN COILS.**  
 PRACTICALLY every type of coil is manufactured by Colvern, Ltd.—from the single six-pin type of coil for a single valve, to the complete set of screened coils for a multi-valve sup.-het. This firm also issues a very interesting book, showing how to use all the types of coil, and giving also much other interesting information for the enthusiastic amateur. The book will be supplied free to those readers who care to write to the firm at Mawney's Road, Romford, Essex.

**MAINS SWITCHES.**  
 THE principal considerations in the design of a switch for use in conjunction with the mains are good current handling capabilities, and a good, quick make-and-break action. The control knob also needs thorough insulation. All these points are fully satisfied in the interesting line of switches manufactured by Geo. Becker, Ltd. Apart from the smaller types of 2 and 4 amp. switch, the most interesting sample submitted to us was a switch intended for mounting on an all-metal chassis, before such chassis is inserted into a cabinet. The control knob may then be screwed into the switch from outside the cabinet, an escutcheon being attached to the wooden cabinet and bearing the indications "On" and "Off." This switch is rated at 4 amps., and will carry comfortably three times this current without breakdown. The price of this switch is 2s. 6d.





## VALVES DO NOT DIE SUDDENLY —

Except by accident or final collapse. Like old soldiers they simply fade away and your reception fades with them.

To secure the best entertainment and full value from your expenditure on radio, your valves must be as good as your receiver will admit. Some modern Six-Sixty valves have a "Goodness" factor ten to twenty times greater than that obtainable a year or two ago.

Take the valves you are now using (of any make) to a SIX-SIXTY VALVE SERVICE STATION and have them tested. No charge is made for testing or advice. You will get a straight report on their condition and suitability for any specified purpose, and particulars of latest type equivalents should you desire this information.

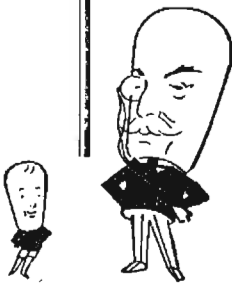

Write to us for the address of the Six-Sixty Valve Service Station nearest to you.

# SIX-SIXTY

B.V.A. RADIO VALVES and EQUIPMENT

Six and Sixty  
AT YOUR SERVICE

Six-Sixty Radio Co., Ltd., Six-Sixty House, 17/18, Rathbone Place, Oxford Street, London, W.1.

# £4,625

## CASH PRIZES

### OFFERED TO READERS OF

# TIT-BITS

On Sale Saturday

Price Twopence

**Chat About the Latest Components**  
(Continued from page 58.)

**BLEKTUN TRANSFORMERS**

Amongst the many new components submitted to us by Slektun Products, Ltd., the transformers are of special interest. These are divided into two types, a standard size instrument selling at 8s. 6d., and a small one called the Colt, priced at 4s. 0d. These transformers are supplied in black bakelite cases in four ratios—5-1, 4-1, 3-1, 2-1. With a guarantee for three years these transformers may be used with every confidence.

**"GOLSTONE" COILS**

Several new ranges of coil are being produced by Messrs. Ward and Goldstone—a metal cover and base being supplied so that the complete coil may be screened. In addition to normal aerial coils providing three different types of aerial circuit with reaction, an ingenious H.F. coupling unit calls for special mention. In addition to the coil, this assembly contains H.F. decoupling components, the H.F. coupling condenser and a metal cased connecting lead. The entire unit is enclosed in a metal can, and owing to the shortness of the leads all risk of I.F. instability is removed. This unit costs 9s., and the aerial coils above-mentioned sell at 5s. 9d.

**SCREENS PAREX CHASSIS**

for the

**"LONG RANGE EXPRESS 3"**

ALUM. PANEL 12" x 8" already drilled 4/-  
ALUM. BASEBOARD, 12" x 13" " 5/6

As specified on page 34.

**E. PAROUSSI,** 10, Featherstone Bldgs., H. Holborn  
W.C.1. Phone: Chanc. 7010

**10,000 GRAMMOTORS FROM STOCK.**

Big Cash Discount Allowed! Make a Gramophone or Radiogram. Order loose kits or sets and assemble them at home. Get for 3d. our new 64-page catalogue with scale drawings and instructions how to make them. We sell motors from 7/6, tone-arms, sound boxes, 1/6, pick-ups, big volume horns, loudspeakers, radio kits, complete receiving sets, gramophones, radiograms. Repairs done. Established 1903.  
The REGENT FITTINGS Co., D.285, 120, O'd Street, London, E.C.1.



**COSSOR KITS**

A. C. Cossor, Ltd., are renowned not only for their valves (their new variable mu is highly efficient and has unusually efficient characteristics), but also for their Melody-Maker kits, and their new model No. 335 Melody-Maker 3-valve kit includes the variable mu valve, shielded coils, all-metal chassis and a loud-speaker built into a handsome cabinet. This sells at 27 17s. 6d., and the construction is greatly simplified by the lucid and ample diagrams supplied.

**SOLID GOLD FOR FUSES!**

A new range of radio fuses have recently been put on the market by Microfuses, Ltd., 30, Clerkenwell Road, London, E.C.1, which make use of gold leaf instead of the usual wire. The fusing current depends upon the length, width and thickness of the gold leaf, which is riveted to a celluloid base and held by a special spring clip mounted on a bakelite base.

These new fuses are definitely superior to the old type radio fuses. For one thing they are much more exact in their values; they can be obtained at all carrying capacities from 3 milliamperes to 750 m.A. In addition, the resistance of the gold leaf is very small, and in many radio circuits that is of considerable importance. These new fuses are no more expensive than their predecessors, the actual fuse units retailing at 6d. each, or 1s. each complete with holder.

**TWO-IN-ONE AND THREE-IN-ONE VALVES**

Do you know that you can get a single valve that will give you two stages of H.F. amplification? Do you realise that there is a valve on the market which in a single bulb contains all the elements of a complete detector, R.C., and power valve, and which can be wired up with the necessary coupling components to make a complete receiving set?

These double and triple valves, as they are called, offer a most fruitful source of experiment to the keen amateur. Manufactured by Loewe Radio Co., Ltd., Fontayne Road, Tottenham, they do not work out any cheaper than their equivalent in ordinary valves, but think of the saving of space which can be effected, the novel circuits that can be devised around them. Why not have a two-stage H.F. set, giving you immense range, band-pass tuned for extreme selectivity, followed by the detector and two low-frequency stages? That would be a set to satisfy the desires of the most persistent distance-searcher as well as the taste of the most critical music lover. And it could all probably be housed in a cabinet no larger than that usually occupied by a straight three valve set.

The Double Valve containing the elements of two H.F. stages costs 25s. The Triple Valve, in its latest metal-coated form, can be had either directly heated for battery operation, or indirectly heated for A.C. mains, price 33s. 6d. each.

**LEWCOO POTENTIOMETER**

The well known Lewcoo products, which, of course, are manufactured by the wire specialists, The London Electric Wire Co. and Smiths Ltd., who manufacture everything in radio which uses wire, have really surpassed themselves in producing the new Lewcoo potentiometer, which at once gets rid of all of the disadvantages formerly existing with potentiometers. Instead of the usual sliding rotary contact, an inclined disc the full diameter of the former on which the wire resistance element is wound is rotated by the knob and acts in the same way as a wiper plate. It is the best potentiometer we have yet tried, and under test it at once got rid of certain disadvantages of potentiometer control which we encountered in a new variable mu circuit we are preparing. At the very low price of 3s. it is remarkable value for money. It is marketed in 50,000 ohms to carry 7 milliamps, 25,000 ohms for 10 milliamps, 10,080 will carry 15 milliamps, 5,000 20 milliamps, 1,000 25 milliamps. They can also be supplied in the Logarithmic pattern. This company, of course, make the well known Lewcoo Spaghetti resistances, the coloured Glazite connecting wire, Lewcoo coils, transformers, etc.

**TUNEWELL COILS**

The Tunewell Radio Ltd. are marketing a complete range of mains components and eliminators, a truly comprehensive range of coils of all types from ultra-short wave upwards, both plug-in, six-pin, dual-range, etc., chokes, variable resistances, band-pass coils, etc. We have recently tested a set of their band-pass tuning coils, and under test we found them very efficient. Those who would like lists should address a letter to 34, Station Road, New Southgate, London N.11.

**Faulty Connections**

(Continued from page 30.)

is the right way for connecting speakers of the unbalanced armature type, by the following dodge. First of all, switch off the set, but leave the speaker connected. Turn the adjusting screw at the back until the armature is just clear of the magnets. This is indicated by a strong "pop." Not a "click," for that indicates just the opposite, that the two parts have come in contact. Now switch on the set, and if the speaker is connected up the correct way, the reed or armature will be heard to "click" up against the magnets. It must then, of course, be readjusted while the set is still switched on.

**Ten Splendid Handbooks**

1/- each  
(by post, 1/2)

- 25 Tested Wireless Circuits - - By F. J. CAMM.
- 25 Simple Working Models - - By F. J. CAMM.
- (Model Aeroplanes and Airships)
- The Handyman's Enquire Within.
- The Home Woodworker.
- Motor Car Upkeep and Overhaul By F. J. CAMM.
- Accumulators: Charging, Maintenance and Care - - - - - By F. J. CAMM.
- Toy Making for Amateurs. Model Boat Building.
- Simple Electrical Apparatus.

**ISSUED ANNUALLY**

The Motor Cyclist's Reference Year Book.  
Edited by F. J. CAMM.  
(An Encyclopaedia for Motor Cyclists, which deals with every branch of the pastime).

From any Newsagent, or by post 1/2 from GEO. NEWNES, LTD., 8/11, Southampton Street, Strand, W.C.2

**OUR LATEST & MOST WONDERFUL RADIO OFFER!**

**THE FAMOUS BROWN 1933 P.M. MOVING COIL UNIT AND CHASSIS**

A new permanent magnet Moving Coil Unit and Chassis, including tapped transformer. Extremely sensitive, suitable to work with any good 2- or 3-valve set; gives volume without distortion; protected to prevent entry of dust or metal particles. Fitted complete on Baffle Board.

Height 12ins., Width 12ins., Depth 4ins. Only a limited number available at this special price.

**IN MAGNIFICENT WALNUT CABINET**  
The same speaker in cabinet of special design. List Price, £3 10s. 6d. OUR PRICE, only £2 19s. 6d. Send 2/6 deposit, for 7 days trial. If satisfied, send further 2/- and 8 monthly payments of 7/6.

**List Price 50/- OUR PRICE only 32/6.**  
On 7 days approval—only 2/6 deposit; if satisfied, pay further 2/- at or s. then, 6 monthly payments of 2/- (Cash in 7 days 32/6.) Leaflet post free on request.  
**E. J. HERAUD, LTD., DEPT. P.1**  
NUMBER ONE, EDMONTON, LONDON, N.16

**Clarion**

PICK-UP and  TONE-ARM

IS THE ALL-BRITISH PICK-UP RECOMMENDED BY THE DESIGNER OF THE

**"LONG RANGE EXPRESS"**



described on page 34 in this issue.

**NO CHATTER NO SCRATCH NO CASE RESONANCE AMAZING REALISM**

FITTED TO ANY GRAMOPHONE IN 5 MINUTES

PRICE 21/-

**BRITISH CLARION CO., LTD.**  
CLARION WORKS, MILLER ST., CAMDEN TOWN, N.W.1  
Phone: Museum 3624-5. Telegrams: "Crosradcla, Norwest, London."

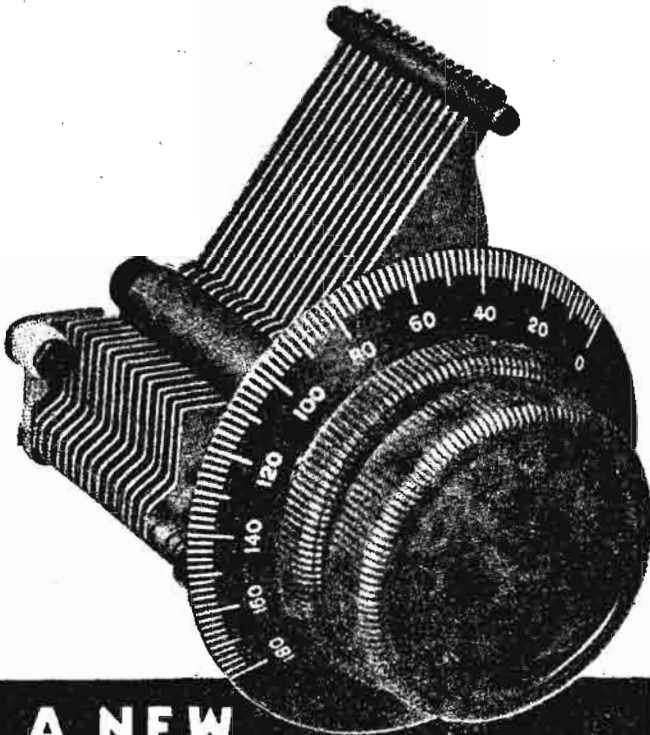

**A NEW**  
*Utility* **MITE**

Here is the new Utility Mite, with vernier; a better job than ever and that is saying something, because the old Mite was the finest small condenser made.

Its accuracy is of the highest possible order, its geared slow motion drive is as beautiful an action as you could wish for, and its price is no higher than many a cheaper and inferior job.

If your dealer cannot show you the range, write to us for full particulars.

**PRICES**

- W319 .0005 mfd. as illustrated, 6/6.
- Less vernier 4/- W320 .0003 mfd. 6/6.
- Less vernier 4/- W321 .0002 mfd. 6/-.
- Less vernier 3/6.

*From your dealer or post free from the makers.*

**WILKINS AND WRIGHT LIMITED**  
UTILITY WORKS, HOLYHEAD ROAD, BIRMINGHAM

AGENTS.—London: E. R. Morton, Ltd., 22 Bartlett's Buildings, Holborn Circus, E.C.4. Scottish: E. B. Hemmond, 113 Vincent Street, Glasgow. Lancashire and Cheshire: J. R. Lister, 83 Old Road, Blackley, Manchester. Westmorland, Cumberland, Durham, Northumberland, Yorkshire, and Derbyshire: H. C. Rawson, Ltd., 100 London Road, Sheffield. Lawrence Fraser, Chelsea House, Lansdown Road, Bath.



Belmont

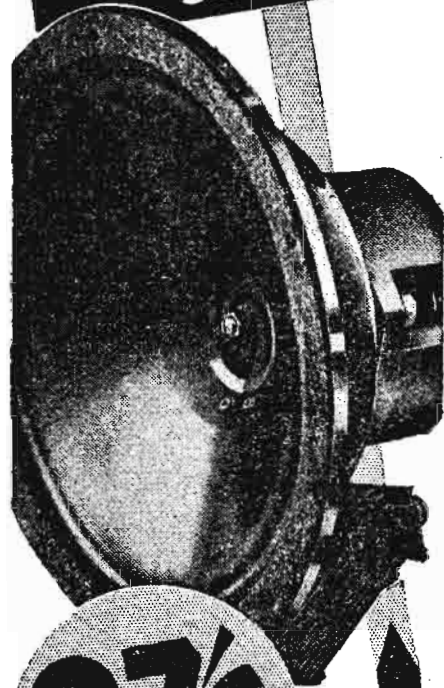

**27/6**

**INCLUDING TRANSFORMER**

This chassis is unique where economy of space is an important factor. Although small in size—the diameter is only 6 1/2"—the volume and tone are truly remarkable.

The "Soundex" gives amazing selectivity. A universal tapped transformer is built on to the chassis. Look where you will, at 27/6 greater value is unobtainable.

Chosen by the designers of the "Long Range Express Three," you can be certain of getting the best possible results if you follow the choice of experts.

Visit your dealer for a demonstration and write for full particulars.



Celestion Ltd., London Rd., Kingston-on-Thames, London Showroom: 106, Victoria Street, S.W.1.

Tune in  
on  
this

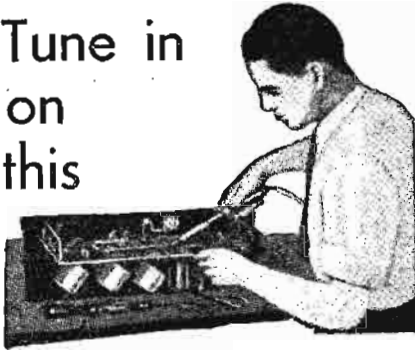

## NEW WIRELESS INSTRUCTION

The I.C.S. Wireless Courses cover every phase of wireless work, from the requirements of the youth who wishes to make wireless engineering his career to the man who wants to construct a broadcasting set for his home, and, at the same time, to know how and why it operates and how to locate any faults that may develop.

No branch of industry has ever progressed as rapidly as wireless, and the rate of progress is increasing. Only by knowing thoroughly the basic principles can pace be kept with it. Our Instruction includes American developments and practice in addition to British. It is a modern education in radio, covering every department of the industry, and gives an outline of the principles and possibilities of television.

### Our Courses

Included in the I.C.S. range are Courses dealing with the Installing of radio sets and, in particular, with their *Serviceing*, which to-day intimately concerns every wireless dealer and his employees. The Operating Course is vital to mastery of operating and transmitting.

There is also a Course for the wireless salesman. This, in addition to inculcating the art of salesmanship, provides that knowledge which enables the salesman to hold his own with the most technical of his clients.

We will be pleased to send you details of any or all of these subjects. Just mark and post the coupon, or write in any other way—the information you require will be forwarded at once.

### YOU MAY USE THIS COUPON

INTERNATIONAL CORRESPONDENCE SCHOOLS, LTD.,  
Dept. 94, International Buildings, Kingsway, London, W.C.2.

Without cost or obligation, please send me full information about THE I.C.S. RADIO COURSES.

Name..... Age.....

Address .....

### What Is Distortion?

(Continued from page 24.)

are a good guide of acceptance or handling powers, in order to be on the safe side and avoid distortion it is preferable to apply a smaller signal voltage than that which the valve is apparently capable of handling. In this way you will have a margin to spare and no attempt will be made to run the receiver all out.

#### Reaction.

Unfortunately, absence of space prevents my dealing with several other points fully, but in conclusion mention must be made of reaction. Keep this control adjusted so that it is as far off oscillation point as possible, and bear in mind that reaction badly designed or badly handled is a notorious agent for detracting from good reproduction.

Then, again, we have to consider the detector valve. If working as a "leaky grid," care must be taken that the impressed signal does not overlap the bottom bend of the valve characteristic. There is a risk of this when strong signals are handled at this stage, and if this does occur a secondary, or what is known as anode bend, rectification will occur and introduce serious distortion. For strong signals one should resort to normal anode-bend rectification or, alternatively, use what has recently come to be known as "power-grid" detection.

Enough has been said, however, to show that at almost every point in your receiver distortion can occur, and in future articles this very important side of wireless which has been just touched on here will be gone into more fully.

### Broadcast Query Corner.

UNDER the above title, with the assistance of a recognised authority on foreign broadcasting matters and a regular contributor to wireless publications both at home and abroad, we are inaugurating a special Identification Service, which should prove of great assistance to our readers. When tuning in well-known stations it happens frequently that listeners pick up wireless transmissions of which they fail to recognise the origin. It is to solve these little problems that the *Broadcast Query Service* has been organised.

In order that a careful search may be made it is essential that certain data should be supplied to the best of the inquirer's ability and knowledge. When sending such queries to the Editor the following rules should be followed:—

1. Write legibly, in ink. Give your full name and address.
2. State type of receiver used, and whether transmission was heard on headphones or on loud-speaker.
3. State approximate wavelength or frequency to which receiver was tuned, or, alternatively, state between which two stations (of which you have the condenser readings) the transmission was picked up.
4. Give date and time when broadcast was heard. Do not forget to add whether a.m. or p.m.
5. Give details of programme received and, if you can, some indication regarding the language, if heard.
6. State whether and what call was given and/or kind of interval signal (metronome, musical box, bells, etc.) between items.
7. To facilitate publication of replies, append a *nom-de-plume* to your inquiry.

Although the service is mainly applicable to broadcasting stations, wherever possible replies will be given in regard to morse transmitters (commercial stations, fog beacons, etc.) and short-wave broadcasts. For the identification, however, of stations operating on channels below 100 metres it will be evident to inquirers that a closer estimate of wavelength must be submitted than in the case of broadcasts on the medium or long wavebands, if successful identification is to be carried out.

All inquiries should be addressed to *The Editor, PRACTICAL WIRELESS, 8-11, Southampton Street, Strand, London, W.C.2,* and the envelope marked *Broadcast Query Service.* In top left-hand corner. Stamped addressed envelope should *not* be enclosed, as replies cannot be sent by post, but will be published in due course in each issue of *PRACTICAL WIRELESS.*

# TANNOY COILS

● Exclusively  
Specified  
in the  
"LONG-RANGE  
EXPRESS 3"

## 15'6

per Pair

Complete with  
Screening Cases

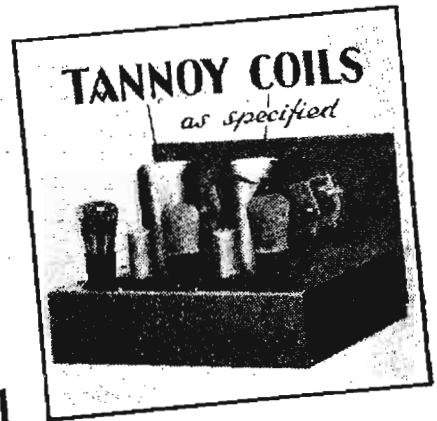

● These coils have been specially designed, and it is essential that TANNOY Coils are used to obtain best results from the above set. Obtainable from:—

● TANNOY PRODUCTS,  
Specialists in High Grade  
Radio Equipment,  
DALTON STREET, WEST  
NORWOOD, LONDON,  
S.E.27.



# THE MOTOR S.40 UNIT

WITH PATENT COMPENSATING ARMATURE

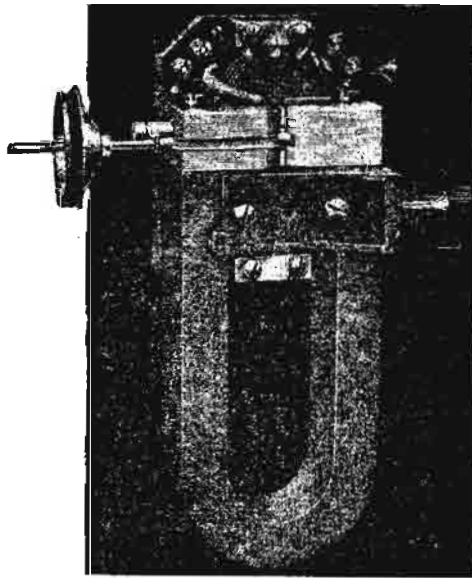
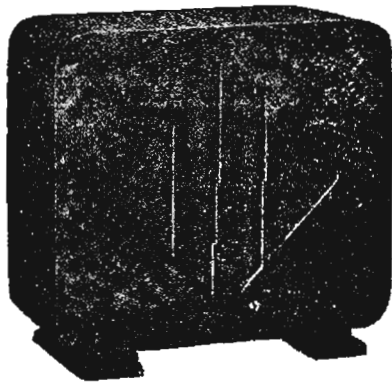

BRITISH MADE.

The greatest advance yet made in perfect loud-speaker reproduction

## Specified for THE "DOLPHIN STRAIGHT THREE"

You will delight in listening to the MoToR S.40 Unit.

Its pure, rich tone, astonishing realism, and super sensitivity are something vastly better in loud-speaker reproduction.

The reason lies in the patent compensating armature and the special device that permits only horizontal vibrations of the transmission reed.

Get the best out of your "Dolphin" with the S.40, and get the best at a moderate price, too.

MoToR S.40 Unit, as illustrated, with patent compensating armature

**27/6**

C.400 Complete Chassis Assembly, with S.40 Unit and Cone

**39/-**

"York." A graceful Walnut Cabinet, as illustrated, fitted with S.40 Unit ...

**52/6**

**TEKADE RADIO & ELECTRIC, LTD.,**  
147, Farringdon Road, London, E.C.1.

Telephone: Clerk, 2486.

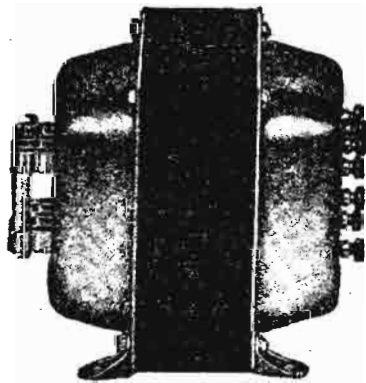

## REVOLUTION IN TRANSFORMERS

A revolution in transformer design is embodied in this, the latest Sound Sales transformer. Totally enclosed. Static. Shielded. Westinghouse type H.8.

This is a transformer you will continuously hear about. Already specified by experts in sets described in the technical press.

Absolutely sound in construction. Cuts out all modulation hum. Cuts down running costs to a minimum. The only transformer incorporating a fuse and combined tapping selector. Absolutely safe. A special fuse protects both your set and your mains.

PRICE **25/-**

WRITE FOR DESCRIPTIVE ILLUSTRATED LIST "3,"  
Telephone: Archway 1661-2.

**SOUND SALES**  
TREMLETT GROVE, HIGHGATE, LONDON, N.19

The *Chakophone* REGD.

**UNIVERSAL AERIAL TUNING UNIT**

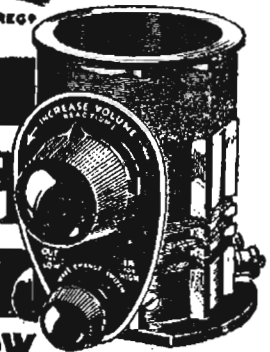

**MODELS NOW AVAILABLE**

HERE is a Tuning Unit which brings in stations all around the dial. It is fitted with an oxydised panel ready for mounting on the set. It embodies a reaction coil which dispenses with a condenser. It is suitable for a two or three-valve set. It is made in two models, Standard and Selective. The two used together make an excellent combination should you desire to construct a Screen Grid Circuit. Price 10s. 6d. each.

PRICE **10/6 EACH**

A wiring diagram is supplied with every coil. Ask for one at your dealers or send to us.

★entirely British made

**EAGLE ENGINEERING CO., LTD.,**  
**WARWICK.**

# CONCERNING ATMOSPHERICS

**A**LTHOUGH atmospheric seldom make wireless reception impossible in this country, they are, nevertheless, very disturbing at times, especially with long-distance reception during warm weather. Common causes of atmospheric are lightning discharges in the atmosphere, or the gradual equalising of potential between charged clouds or a cloud and the earth. Unfortunately for the listener, these

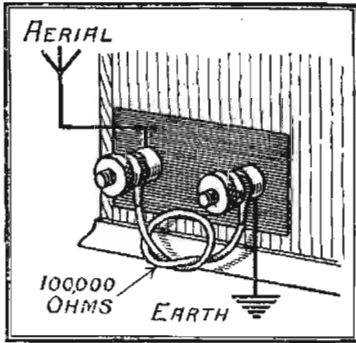

Fig. 1.—A spaghetti resistance between aerial and earth.

atmospherics have no particular frequency, so that they cannot be tuned out by ordinary means. Another point to bear in mind is that the atmospheric may be much stronger than the signals from a distant station, consequently, when conditions are bad, it is useless to introduce very much amplification, because in that case the atmospheric would be amplified as well as the incoming signal.

### Background Noises

Sometimes you may be doubtful as to what is causing the background noises in your receiver—it may be atmospheric or only a failing battery. A simple method of proving this point is to disconnect the aerial and earth. If the trouble ceases it is evident that atmospheric were the cause. When atmospheric are about, the listener soon discovers that, no matter how carefully the set is tuned, they still persist in coming through, but with decreasing intensity as the lower wavelengths are tuned in. The aperiodic nature of atmospheric makes it extremely difficult, if not impossible, to entirely eliminate them. Engineers and scientists have been trying—ever since wireless was first introduced—to get rid of atmospheric, but so far without any real success. Different methods have

been tried out, but they are too complicated to be of any use to the average amateur.

### Cutting Down Atmospheric

One of the simplest ways of cutting down the intensity of atmospheric is to lower the aerial. A long, high aerial seems to be a much more efficient collector of atmospheric than a low one. When altering the aerial, however, it must be borne in mind that when in its lowered position its signal pick-up efficiency will be reduced, which will mean more amplification for bringing in a distant station. The extra amplification might increase the intensity of the atmospheric, but if the required signals can still be heard at good strength on the lowered aerial, without additional amplification, then the effect should be a reduction of interference.

### A By-pass for Static Discharges

A high resistance connected between the aerial and earth terminals of a receiver is sometimes effective in cutting down atmospheric, by acting as a by-pass for the static discharges. Try various values of resistance until the desired result is obtained without unduly diminishing the signal strength. A spaghetti resistance is very handy for this purpose, as shown in Fig. 1.

Another dodge worth trying is to use the earth as an aerial by disconnecting the latter from the set and connecting the earth lead to the aerial terminal, as in Fig. 2, leaving the earth terminal disconnected. This arrangement considerably reduces the range of the set, but often completely cuts out atmospheric, so that reception from the local station can be enjoyed even when conditions are bad.

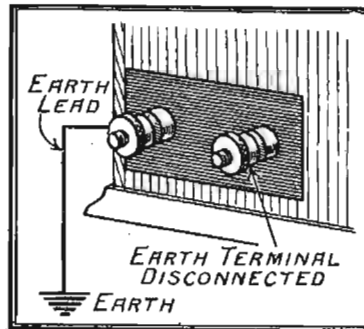

Fig. 2.—Utilising the earth lead as an aerial.

## My Favourite Circuit—And Why

(Concluded from page 32)

because it gives more "punch." No output filter is used as the speaker incorporates a transformer.

From Mr. W. J. Barton Chapple, Wh. Sch., B.Sc. (Hons.), A.C.G.I., D.I.C., A.M.I.E.E.

**I** FIND it difficult to isolate any one particular circuit and call it my favourite.

I have designed so many sets, each built to fulfil a definite function, that I can only say that the diagram shown on page 32 represents one of my favourites.

Let me give readers the reasons for choosing the four-valver shown. First of all it is simple to operate and can be handled by any member of the household, a factor which, in my opinion, is a most important one. Four valves are chosen since this enables one to reach out for stations without "forcing" the set.

Selectivity is amply provided for by the condenser combination on the aerial input side and the degree of magnetic coupling between the tuned circuit and the aerial coil. Incidentally, the differential condenser connected in this way proves most effective as a volume control. Choke feeding between the screen-grid and detector valves enables the tuning condensers to be properly ganged with the moving plates at earth potential, while the single H.T. feed is simpler from the point of view of the mains eliminator, ample provision for decoupling being given in each anode feed.

On the low-frequency side we have a first stage R.C. coupling and a resistance feed-transformer linking up the output valve. There is a choke feed to a transformer, which latter can be tapped to match with the speech coil impedance, assuming a moving coil model is employed. Automatic bias is arranged for.

From F. J. Camm

**I** CANNOT answer this question in the singular, for I have several favourite circuits. If you press me, however, to be more precise than this, I still think that a detector with leaky grid rectification followed by two stages of low-frequency amplification requires a great deal of beating if everything is taken into consideration. The colloquialism has it that "you cannot have it all ways," and if we consider that the Det. 2 L.F. circuit as a basic one from which more modern circuits have been developed, we shall probably find that every improvement in one part of the circuit has introduced corresponding complications in another. It is true that there are certain disadvantages with the arrangement named, but, taken all round, its very simplicity, its ease of construction and operation makes it a delightful circuit for the non-technical amateur.

STAND 45.  
NORTHERN  
NATIONAL  
RADIO EXHIBITION,  
City Hall,  
MANCHESTER  
Sept. 28—  
Oct. 8

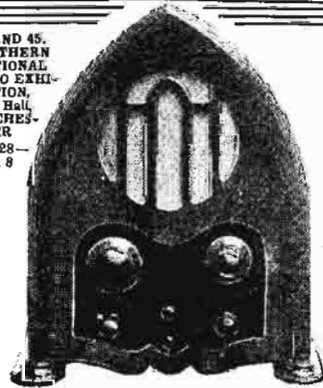

Chosen by "Practical Wireless" Technical Chief for the  
"LONG-RANGE EXPRESS 3" ★

# OSBORN CABINET

CHAS. A. OSBORN (Dept. P.P.W.), Regent Works, Arlington St., London, N.1. Phone: Clerkenwell 5095; and at 21, Essex Rd., Islington, N.1 (2 minutes from Essex Road Tube Station). Phone: Clerkenwell 5634.

Model No. 225. A Gothic Style Radio Cabinet, 20 ins. high x 15 ins. wide x 10 ins. deep. Will take a set 14 ins. x 10 ins. x 8 ins. high. Ample space is allowed for speaker up to 10 ins. diameter hole. Made under a special process that prevents resonance. Baffle and silk included.

**PRICES.**  
ASSEMBLED READY TO POLISH:  
Oak ... .. £0 17 6  
Mahogany ... .. £1 0 0  
Walnut ... .. £1 2 6

ASSEMBLED AND POLISHED:  
Oak ... .. £1 5 0  
Mahogany ... .. £1 7 6  
Walnut ... .. £1 10 0

All Models Carriage Paid.

OSBORN  
SUPER  
ACOUSTIC  
Baffle  
BOARD  
prevents 90% of  
speaker worry.  
Guaranteed no  
vibration even  
when attached  
to most power-  
ful moving  
coil. Any size  
Hole Cut Free.  
18 x 18, 3/-  
24 x 24, 5/-  
30 x 30, 8/-  
36 x 36, 11/3.  
Carriage paid  
U.K. SEND  
FOR SAMPLE

SEND FOR FREE CATALOGUE OF LATEST MODELS POST FREE.

REPLIES TO

LET OUR TECHNICAL STAFF SOLVE YOUR PROBLEMS

The coupon below must be attached to every query.



If a postal reply is desired, a stamped addressed envelope must be enclosed. Every query must bear the name and address of the sender. Send your queries to The Editor, PRACTICAL WIRELESS, Geo. Newnes, Ltd., 8-11, Southampton St., Strand, London, W.C.2.

QUERIES and ENQUIRIES by Our Technical Staff

ADDITIONAL SMOOTHING.

"My set is supplied with H.T. from a commercial make of battery eliminator, and I feel that the smoothing is inadequate. Can I improve this without taking the eliminator to pieces?"—(J. D., Harrow).

Yes, the alteration would be quite simple. You require a 2 mfd. condenser and a good L.F. choke. Connect the choke in the H.T. positive lead—between eliminator and receiver—and join one terminal of the condenser to the H.T. positive terminal of the receiver, and earth the other condenser terminal.

UNSPILLABLE ACCUMULATORS.

"Can you tell me how unspillable accumulators are made up?"—(K. O. J., Dalston).

There are three main methods adopted by manufacturers in making unspillable accumulators. One type used is glass-wool saturated with diluted acid, which is inserted between the plates. Another type used is the jelly form of acid. The third type incorporates a device known as a non-return valve which enables the acid to be put into the accumulator, but will not allow it to come out.

CONNECTIONS OF REACTION COIL.

"In a receiver having one or more stages of high-frequency amplification, I understand that the reaction coil may be coupled either to the tuned-anode coil of the high-frequency valve or to the aerial tuning coil. Which method gives the louder signals?"—(L. V., Cirencester).

Louder signals will be obtained if the reaction coil is coupled to the aerial coil because the amplifying powers of the first valve are employed to magnify the signals passed originally by the detector valve into the reaction coil. If the reaction coil is coupled to the tuned-anode coil, the first valve is not made use of, except in its ordinary capacity as high-frequency amplifier. To be on the safe side, if you have other receiving sets near you, it will be advisable to react on to the tuned-anode coil. You will lose a little signal strength, but will not be so liable to set up oscillation in the aerial.

CAPACITY OF ACCUMULATOR.

"How is the capacity of an accumulator calculated?"—(B. S., Lancaster).

The "capacity" or holding power of an accumulator is rated per square foot of positive surface (both sides). The number of negative plates in a multi-plate cell exceeds the number of positive plates by one. A 100 ampere-hour cell will give a continuous discharge of 5 amperes for 20 hours or 1 ampere for 100 hours. The capacities of accumulators vary considerably with the make, size, etc., but an average value for the "pasted-plate" type is about 10 ampere-hours per square foot (both sides).

FRAME AERIAL DATA.

"I wish to make a frame aerial and should be glad to know the relation between the size of the frame, number of turns, etc. Any other details relating to this type of aerial would also be welcome."—(L. S., Bridport).

The following table should prove useful in constructing a frame aerial:—

Length of Side of Square Frame	Number of Turns	Space between Wires	Inductance (Micro-henrys)	Self-capacity (Micro-farads)	Natural Wavelength in Metres
8ft.	3	1in.	98	75	160
6 "	4	"	124	66	170
4 "	6	"	154	55	175
3 "	8	"	193	49	185

A.A. WEATHER REPORTS.

"I understand that weather reports are broadcast from one of the London aerodromes. Can you tell me the wavelength and power of this broadcast?"—(S. M., Dulwich).

The reports in question are broadcast from Heston Aerodrome on a wavelength of 833 metres. The power of the transmitter is 300 watts.

AN OUTPUT FILTER.

"I wish to use my loud-speaker in the drawing-room, but have no desire to move the receiver (which is a large cabinet radio-gramophone) from the dining-room. I believe the long leads will spoil the efficiency of the receiver. Is this so? If it is, how can I carry out my proposal without loss of efficiency?"—(A. F. C., Preston).

An output filter (if one is not already fitted to the receiver) will be sufficient to enable you to run leads of any length for the L.S. A L.F. choke and a 2 mfd. condenser are necessary. The choke is joined across the L.S. terminals of the receiver, and one terminal of the condenser is joined to the L.S.—terminal of the set. One extension lead is then joined to the remaining terminal of the condenser, and this is taken to either terminal of the speaker. A wire from the remaining speaker terminal to any convenient earth completes the arrangement.

FLASHING-SIGN DISTURBANCES.

"I live next door to a large shop employing a sign of the flashing variety. While this is working I get

Cut this out each week and paste it in a notebook

PRACTICAL WIRELESS Data Sheet No. 1

No.	Dia.	Tap Drill No.	Clearing Drill No.
*0	.236	12	15/64
1	.209	19	4
*2	.185	26	13
3	.161	30	20
*4	.142	34	28
5	.126	40	30
*6	.110	44	35
7	.098	48	40
8	.087	51	44
9	.075	53	48
10	.067	55	51
11	.059	57	53
12	.051	62	55

The sizes marked with an asterisk (\*) are those chiefly used in wireless construction. The tap drills and clearing drills may be obtained in sizes 1 to 60, No. 1 being .228in. dia., and No. 60 .04in. dia. Beyond No. 1 drill size letter drills from A to Z may be obtained, A being .23in. dia., and Z .413in. dia.

tremendous crashes in my speaker. Is it possible for me to cure this trouble?"—(F. W., Kensington).

The remedy must be carried out by the owners of the sign. You, unfortunately, can do nothing. At the recent Radio Exhibition, the Post Office Engineering Department exhibited signs of this type, amongst other apparatus giving rise to disturbances, and demonstrated the cure. Two large heavy-duty chokes in the mains leads was the remedy suggested, and the exhibit proved the efficacy of the arrangement. Perhaps if you called on the owner of the sign and explained matters, he would instal the necessary apparatus.

GRAMO-PICK-UP.

"Can a gramophone pick-up be connected to any set, or must a mains set be used? If an ordinary set will do, how do I connect it up?"—(F. A. S., Glasgow).

Any receiver having at least one L.F. stage may be used with a pick-up. The pick-up must be connected between the grid of the valve and the valve must be correctly biased via the pick-up. A simple single-pole-change-over switch may be used to change from radio to gramophone, or the pick-up may be joined across the grid circuit of the detector valve, and the receiver detuned to avoid radio signals breaking through when the pick-up is in use.

MAINS VALVES.

"I recently made up an all-mains receiver, but, unfortunately, the two A.C. valves burnt out in three days. I bought two new valves and checked the wiring, which was quite O.K., but the new valves also only lasted a week. Can you suggest the cause of this before I buy any more valves?"—(A. P., Bromley).

The most likely cause of this, A. P., is that the heater winding of your mains transformer is designed to supply more valves than you are using. The result of this is that the two valves you are using are receiving more current than they are rated to take. You will need to limit this by providing external loading to the secondary, so that the current agrees with the load which the transformer is designed to take. A resistance across the heater winding will do this, but it must be capable of carrying the current which will amount to 2 amps. or so.

HUM CAUSE AND CURE.

"I live in a flat, and have a fairly powerful S.G. Three which is battery-driven. I am troubled, however, by a bad hum in the speaker—which is a permanent magnet moving coil. Can you suggest the cause and cure?"—(F. J. A. R., Gloucester).

As you live in a flat, you are probably using an indoor aerial. This may have been suspended in such a position that it runs parallel with the house mains wiring. This will often give rise to hum, and the cure is, of course, to alter the position of the aerial.

ADDITIONAL AERIAL FOR PORTABLE.

"I have a 5-valve portable receiver built in an ordinary small suit-case. I wish to use this with an ordinary outdoor aerial, but there appears to be no sockets or terminals provided for this purpose. Can I attach the aerial in any way—perhaps to one of the variable condensers?"—(J. H., Hastings).

Wind two or three turns of 22 d.c.c. wire round the lid of your portable. (We presume the frame aerial is in the lid.) Connect one end of this winding to the aerial and the other to earth. If this extra winding is too large, selectivity will fall off, and therefore you can adjust the size of this winding to give you the best results.

LOUD-SPEAKER Baffle.

"Must a baffle board—to be used with a loud-speaker—be of any specific thickness? I have a large sheet of three-ply wood available, and would like to use this, if possible."—(R. P., Bangor).

Thin three-ply would be inclined to resonate, making the reproduction boomy. The baffle should be thick enough not to vibrate, and in general a good 5 or 7-ply board 3in. thick will be found quite suitable.

USING A PENTODE.

"I have fitted a pentode in place of the original power valve in my set, but am disappointed with the results. The reproduction is terribly high-pitched and squeaky. Can I remedy this?"—(R. P., Watford).

If you have simply replaced one valve with another—reproduction will be rather high. You will have to use either a pentode output transformer, or a special pentode choke, with tone control device, in order to match the higher impedance of the pentode. There are a number of pentode output filters, etc., on the market which you will find suitable.

AUTOMATIC GRID BIAS.

"I have a battery-driven receiver consisting of S.G., detector and L.F. valve. I believe it is possible to use an automatic biasing scheme similar to mains-driven sets. Is this so? If so, how can I fit it to my receiver?"—(J. S. M., Dulwich).

Exactly the same procedure is adopted in either battery, or mains-driven sets—namely, a resistance is inserted in the H.T. negative lead. The value will depend upon the anode current of the L.F. valve, and this must be divided into the voltage required for grid bias. The anode current should be expressed in amps, and then the answer will give you the value of the biasing resistance in ohms.

FREE ADVICE BUREAU COUPON

This coupon is available up to Oct. 1st, 1932, and must be attached to all letters containing queries.

PRACTICAL WIRELESS, 24/9/32

# QUICK EASY PAYMENT SERVICE

We supply all good quality Radio Receivers, and Accessories on deferred terms. Large stocks are carried and orders are executed promptly. Send list of requirements and a quotation will be sent by return of post. Price List free on request.

### MANUFACTURERS' KITS

**NEW COSSOR MELODY MAKER, Model 335** (just released). Complete Kit of Parts, Valves, and Loud-Speaker and Cabinet. Cash Price, £7/17/6. And 11 monthly payments of 14/10. With 10/- order

**NEW TELSEN JUPITER S.G.3. KIT.** Complete set of Components, less Valves. Cash Price, £3/17/-. And 11 monthly payments of 7/-. With 7/- order

**NEW LISSEN "SKY SCRAPER" KIT.** Cash Price, £4/9/6. And 11 monthly payments of 8/3. With 8/3 order

**NEW TELSEN AJAX 3.** Complete Set of parts for Det.; 2 L.F. Receiver, less Valves. Cash Price, £3/1/6. And 11 monthly payments of 5/8. With 5/8 order

**READY RADIO "METEOR" S.G.3 KIT,** including cabinet, valves, and moving coil unit. Cash Price, £8/17/6. And 11 monthly payments of 16/8. This Receiver tunes to Ultra-short Waves. With 11/- order

**READY RADIO 303 KIT,** Cabinet Model, including moving-coil unit and valves. Cash Price, £6/17/6. And 11 monthly payments of 12/9. With 10/- order

**NEW MARCONIPHONE 2-VALVE BATTERY RECEIVER, Model 248.** Including Valves, Batteries, and Loud-speaker. Ready for use. Cash Price, £4/19/6. And 12 monthly payments of 8/3. With 9/- order

**NEW ORMOND PERM. MAGNET MOVING-COIL L.S. UNIT.** (Just released) Cash Price, £1/18/6. And 7 monthly payments of 5/4. With 5/4 order

**ATLAS ELIMINATOR, A.C.244, 3 H.T. Tappings.** 20 M/A output. Cash Price, £2/19/6. And 11 monthly payments of 5/6. With 5/- order

**NEW R. & A. "CHALLENGER" PERM. MAGNET MOVING-COIL UNIT.** Cash Price, £1/15/-. And 6 monthly payments of 5/8. With 5/- order

**NEW EPOCH 20c. PERMANENT MAGNET MOVING-COIL UNIT.** Cash Price, £1/15/-. And 6 monthly payments of 5/7. With 5/7 order

**NEW BLUE SPOT 99 P.M. MOVING-COIL UNIT.** One of the finest Units available. Cash Price, £2/19/6. And 11 monthly payments of 5/6. With 5/- order

**NEW R. & A. "VICTOR" PERM. MAG. MOVING-COIL REPRODUCER DE-LUXE.** With 6 Ratio Transformer and Cadmium plated Grill. Cash Price, £3/10/-. And 11 monthly payments of 6/5. With 6/5 order

**BLUE SPOT 100U. INDUCTOR UNIT.** Cash Price, £1/19/6. And 7 monthly payments of 5/5. With 5/5 order

To avoid delay, will customers kindly send first payment with order. All above carriage paid.

The **LONDON RADIO SUPPLY COMPANY** ESTD 1925  
11, Oat Lane, Noble St., LONDON, E.C.2  
Phone NATIONAL 1977

## CATALOGUES RECEIVED

To save readers trouble, we undertake to send on catalogues of any of our advertisers. Merely state, on a postcard, the names of the firms from whom you require catalogues, and address it to "Catalogues," PRACTICAL WIRELESS, Geo. Neumes, Ltd., 8/11, Southampton St., Strand, London, W.C.2.

### BULGIN COMPONENTS.

AN attractive catalogue just issued by A. F. Bulgin and Co., Ltd., contains a very comprehensive range of high-class components covering everything the constructor is likely to require. Included in the list are the new Bulgin Transcoupler: "Quickwyre" for facilitating rapid and neat wiring, and a fine assortment of mains and battery switches. As usual, in the back part of the catalogue there is a useful illustrated technical manual giving instructive information and showing how various Bulgin components are connected in different circuits.

### COLVERN COILS.

IN the new season's booklet received from Colvern, Ltd., particulars are given of a new dual-range coil known as the T.D., among their other numerous types. These new coils can be used in either a detector L.F. type of receiver or in a screen-grid circuit. The booklet can be obtained free on application to Colvern Ltd., Mawneys Road, Romford, Essex.

### PERMANENT MAGNET MOVING-COIL SPEAKERS.

IN a neat folder just issued by Whiteley Electrical Radio Co., Ltd., particulars are given of their well-known permanent magnet moving-coil speakers, including a new model with cobalt steel magnets which sells at the remarkably low figure of 35s. Readers interested in moving-coil speakers should make a point of getting a copy of this folder.

### EDISWAN H.T. BATTERIES.

SOME useful information concerning the Ediswan H.T. and grid-bias batteries is given in a smart booklet issued by the Edison Swan Electric Co., Ltd. Users of these batteries who wish to know how to obtain the maximum length of life from them, together with the highest quality of reproduction from their sets, will find the information in this booklet, which also contains a handy two-page chart for logging stations.

### A USEFUL T.C.C. CATALOGUE.

T.C.C. have produced a booklet on the design and construction of power units which has a most useful gadget on the last page, which takes the form of a calculator showing how many ohms are wanted to drop almost any number of volts with any number of milliamps that may be passing. It costs sixpence, but it is well worth it.

### ORMOND PRODUCTS.

AMONGST the components shown in the latest Ormond list is a new precision condenser with friction control and slow-motion movement with a ratio of 55 to 1. Another new component listed is a logging drum dial with illuminated surface and a bakelite escutcheon plate and control knob. A slow-motion device is incorporated and condensers can be attached on either side.

### CLIX.

CONSTRUCTORS who want to have perfect contact in the wiring connections of their sets would do well to peruse a copy of the latest folder of Lectro Linx, Ltd. A useful range of the popular Clix fittings is shown, including a handy line of master plugs and sockets, and valve-holders for chassis mounting fitted with terminals.

# CLIX FOR PERFECT CONTACT

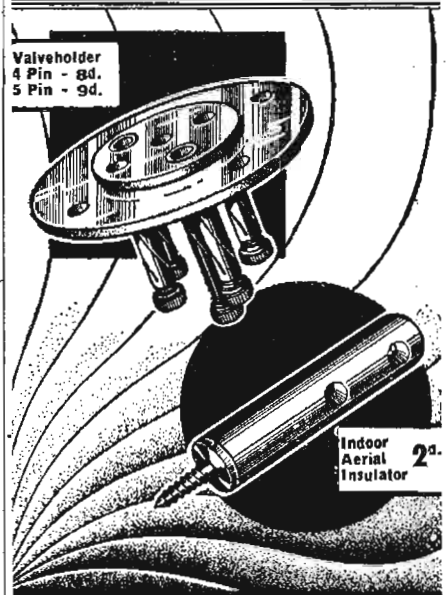

Valveholder  
4 Pin - 8d.  
5 Pin - 9d.

Indoor Aerial Insulator 2d.

## CLIX VALVEHOLDERS (Chassis Mounting)

Specified for the "LONG RANGE EXPRESS THREE"  
See the announcement on page 34, and write for illustrated folder "N" of the full "Clix" range.  
LECTRO LINX LTD., 254, Vauxhall Bridge Rd., S.W.1

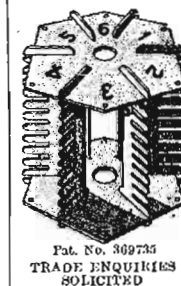

## REGD. "EWEBEC" TRADE MARK

### The Wonderful New Universal COIL FORMER

Ideal for home constructors. Suitable for all wave lengths. Easily wound by hand. No slotting or drilling required. Highest possible efficiency. If unable to obtain at local dealers, sent direct post free if you enclose his name and address.

## EVINGTON ELECTRICAL MANFG. CO.

5 Beekingham Road, Leicester

1/3 with instructions & winding diagrams

## Everything You Want To Know About Wireless

THIS book has been prepared for the non-technical listener. After reading *The Outline of Wireless*, your set, which a few days ago was as a sealed book to you, will now be yours to do with as you will. Many illustrations and diagrams.

# THE OUTLINE OF WIRELESS

By RALPH STRANGER  
832 PAGES

On sale at all Newsagents and Bookstalls, or by post 9/- from George Neumes, Ltd., 8-11, Southampton Street, Strand, London, W.C.2. **8/6**

### DESIGNS FOR APPARATUS FOR ANY RADIO PURPOSE, INCLUDING TRANSMISSION. OVERSEAS ENQUIRIES INVITED; ANY APPARATUS SUPPLIED. CONSTRUCTIONAL WORK UNDERTAKEN.

We undertake to solve your Problems, in addition obtaining Amateur Transmitting Licence. Whatever your difficulty, write us.  
Charges: 3/- per query, four or more, 2/6 each, with diagrams.  
Radio Technical Agency (Dept. P.L.W.), 2, Westgate Chambers, Newport, Mon.

By The Editor of PRACTICAL WIRELESS

# MODERN WIRELESS

Sets and How to Make Them. 6d.  
25 Tested Wireless Circuits. 1/-

Published by George Neumes, Ltd., 8-11, Southampton Street, Strand, W.C.2.



**STUDY  
AT  
HOME**

**YOU CAN HAVE A COLLEGE  
TRAINING IN ALMOST ANY  
CAREER FOR A FEW  
SHILLINGS MONTHLY**

**IN YOUR  
SPARE  
TIME**

**LET ME BE YOUR FATHER**

Unless you are in touch with all branches of industry you cannot see the possibilities of employment, but with our gigantic organisation we are in touch with every sphere of activity, and we know that in many trades and professions there are more vacancies than there are trained men to fill them.



*J.H. Bennett*

WE DO NOT PROFESS TO ACT AS AN EMPLOYMENT AGENCY, BUT WE CERTAINLY ARE IN A POSITION TO GIVE FATHERLY ADVICE ON ALL CAREERS AND THE POSSIBILITY OF EMPLOYMENT THEREIN.

We teach by post all branches of the following vocations, and specialise in all examinations connected therewith. Our advice is always Free.

**THE MOST SUCCESSFUL AND MOST PROGRESSIVE  
CORRESPONDENCE COLLEGE IN THE WORLD**

- Accountancy Examinations
- Advertising and Sales Management
- A.M.I. Fire E. Examination
- Applied Mechanics
- Army Certificates
- Auctioneers and Estate Agents
- Aviation Engineering
- Banking
- Boilers
- Book-keeping, Accountancy and Modern Business Methods
- B.Sc. (Eng.)
- B.Sc. (Estate Management)
- Building, Architecture and Clerk of Works
- Chemistry
- Civil Engineering
- Civil Service
- All Commercial Subjects
- Commercial Art
- Concrete and Structural Engineering
- Draughtsmanship. All branches
- Engineering. All branches, subjects and examinations

- General Education
- Heating and Ventilating
- Insurance
- Mathematics
- Matriculation
- Metallurgy
- Mining. All subjects
- Mining, Electrical Engineering
- Motor Engineering
- Municipal and County Engineers
- Naval Architecture
- Pattern Making
- Police. Special Course
- Preceptors. College of
- Pumps and Pumping Machinery
- Radio Reception
- Road-making and Maintenance
- Salesmanship
- Sanitation
- Secretarial
- Shipbuilding
- Shorthand (Pitman's)
- Structural Engineering
- Surveying
- Teachers of Handicrafts
- Telephony and Telegraphy
- Transport
- Weights and Measures "Insp."
- Wireless Telegraphy and Telephony
- Works Managers

If you do not see your own requirements above, write to us on any subject

**DO NOT DELAY**

THERE MAY BE CHANCES FOR YOU TO-DAY FOR WHICH YOU MAY BE TOO LATE TO-MORROW. EVERY DAY COUNTS IN A MAN'S CAREER.

**IT COSTS NOTHING TO INQUIRE**

WE TEACH BY POST IN ALL PARTS OF THE WORLD  
Also ask for our New Book—FREE OF CHARGE

**THE HUMAN MACHINE**

**Secrets of Success.**

Note Address Carefully:  
**THE BENNETT  
COLLEGE LTD.**  
(Dept. 192)  
**SHEFFIELD**



**An Important New Work**

**NEWNES' ENGINEERING PRACTICE**

To be completed in about 48 weekly parts

A Splendid New Work Dealing With All Branches of Mechanical Engineering, including Steam Engineering, Automobile Engineering, Marine Engineering, Power Generation, Engineering Workshop Practice, and all other applications of Engineering in Everyday Life.

**SCOPE OF THE WORK**

**The Principles of Engineering.**

These are explained in a clear and simple manner illustrated by photographs and cinematograph pictures.

**How It Works.**

Over 50 Different types of machines are treated, including Prime Movers, Pumps, Electrical Machines, Lifts, Cranes, etc.

**The Drawing Office.**

In this section the standard practice in preparing engineers' drawings and designs is fully dealt with.

**The Pattern Shop and Foundry.**

Articles here show the method of constructing patterns of all kinds and the most up-to-date methods of metal casting.

**Workshop Processes.**

In this section Fitting, Turning, Drilling, Milling, Shaping, Planing, and other everyday workshop processes are described and illustrated by hundreds of practical examples.

**The Installation of Machinery.**

This section shows how to erect Prime Movers, Shafting, Pumps, Air Compressors, and all kinds of mechanical appliances.

**Iron and Steel Manufacture.**

The articles in this section have been contributed by some of the best-known authorities, and show clearly the method of producing iron and steel in all the forms used by engineers such as Rails, Girders, Bars, Plates, Sheets and Wires.

**Maintenance and Repair.**

Many articles are included in the work showing how to operate and keep in good repair all kinds of mechanical appliances.

**HUNDREDS OF ACTION PICTURES.**

In addition to the usual line illustrations hundreds of photographs have been specially taken in large engineering works all over the country.

**WHY IT WILL INTEREST YOU.**

The pictures will hold your attention, and you will find that this work makes not only instructive, but also pleasant reading. Here is an opportunity of acquiring a good knowledge of modern engineering practice at a nominal weekly cost.

**THE COMPLETED WORK.**

When completed this work will make several handsome volumes which you will find of constant use for reference purposes. It will be provided with a full Index which will enable you readily to turn up any subject on which you require information.

**PART I  
ON SALE  
SEPT. 28th.**

**MAKE SURE OF  
YOUR COPY BY  
ORDERING IT  
TO-DAY**

**ONE  
SHILLING  
WEEKLY**

Obtainable at all Newsagents and Bookstalls, or 1/2 post free from George Newnes, Ltd., 8-11, Southampton St., Strand, London, W.C.2

# POLAR "No. 2"

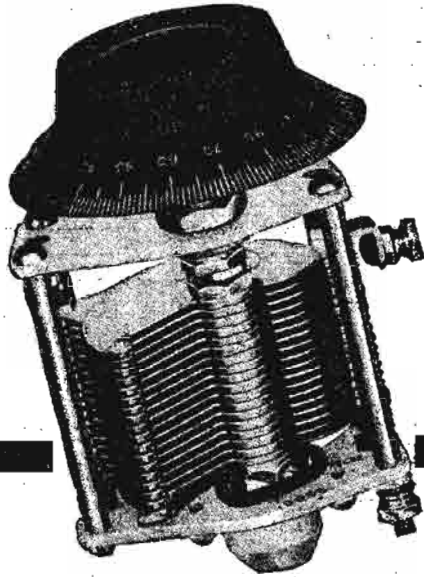

—the Condenser Specified  
for the

## "LONG RANGE EXPRESS THREE"

Owing to its precise workmanship and amazingly low price the Polar "No. 2" has proved itself the outstanding condenser of its type.

Its popular features include fast and slow motion, ball-bearing spindle, positive pigtail connection, one-hole fixing. It follows mid-line law, and is made in hard aluminium with brass pillars for rigidity.

•0005  
•00035  
•0003

6'6

SEND FOR POLAR CATALOGUE "P.R."

# POLAR CONDENSERS



**WINGROVE & ROGERS, Ltd.**  
188-9, STRAND, LONDON, W.C.2.

Polar Works: Old Swan, Liverpool.

## ADVERTISEMENT INDEX

	PAGE
Bennett College, Ltd. . . . .	67
Belling & Lee, Ltd. . . . .	48
British Clarion Co., Ltd. . . . .	60
British Radiogramophone Co., Ltd. . . . .	55
Bulgin, A. F. & Co., Ltd. . . . .	4
Busby & Co., Ltd. . . . .	55
Celestion, Ltd. . . . .	61
Clarion Radio Furniture . . . . .	53
Clarke, H. & Co. (M/cr.), Ltd. . . . .	2
Cossor, A. C., Ltd. . . . .	16
Colvern, Ltd. . . . .	23
Direct Radio, Ltd. . . . .	44
Dubilier Condenser Co. (1925), Ltd. . . . .	48
Eagle Engineering Co., Ltd. . . . .	63
Edison Swan Electric Co., Ltd. . . . .	1, 25
England-Richards, V. . . . .	47
Evington Electrical Mfg. Co. . . . .	66
Formo Co. . . . .	51
Graham Farish, Ltd. . . . .	<i>Back Cover</i>
Hambling, A. W., Ltd. . . . .	55
Heraud, E. J., Ltd. . . . .	60
Igranic Electric Co., Ltd. . . . .	26
International Correspondence Schools . . . . .	62
Jackson Bros. . . . .	51
Lectro Linx, Ltd. . . . .	55, 66
Lissen, Ltd. . . . .	33, 37
London Electric Wire Co. & Smiths, Ltd. . . . .	
<i>Inside Front Cover</i>	
London Radio Supply Co. . . . .	66
Newnes' Complete Wireless . . . . .	<i>Inside Back Cover</i>
Newnes' Engineering Practice . . . . .	67
Newnes' Wireless Constructors' Encyclopaedia . . . . .	56, 57
Osborn, Charles A. . . . .	64
Ormond Engineering Co., Ltd. . . . .	29
Paroussi, E. . . . .	60
Peto-Scott & Co., Ltd. . . . .	3
Pressland Clifford (Sales), Ltd. . . . .	50
Radio Technical Agency . . . . .	66
Ready Radio, Ltd. . . . .	40, 43
Regent Fittings . . . . .	60
Regentone, Ltd. . . . .	20
Six-Sixty Radio, Ltd. . . . .	59
Slektun Products, Ltd. . . . .	15
Sound Sales . . . . .	63
Sovereign Products, Ltd. . . . .	53
Tannoy Products . . . . .	62
Taylor, J. H. . . . .	55
Tekade Radio & Electric, Ltd. . . . .	63
Telegraph Condenser Co., Ltd. . . . .	47
Varley (Oliver Pell Control, Ltd.) . . . . .	19
Whiteley Electrical, Ltd. . . . .	53
Wilkins & Wright, Ltd. . . . .	61
Wingrove & Rogers, Ltd. . . . .	68
Wright & Weaire, Ltd. . . . .	54

# Something NEW for Amateur and Expert



**1/6**  
**PART ONE NOW ON SALE**

# NEWNES COMPLETE WIRELESS

**IN ABOUT 24 WEEKLY PARTS**

## FREE INSIDE

a fine Design Chart containing full instructions and wiring diagram for making a Double-Cone Portable Set which will interest not only you but every one in the Home.

**IF you are a keen amateur**

you will find this is just the work you have been looking for. It explains wireless theory in a way never before achieved. It is packed with really practical articles. Not a square inch of padding in the whole work, and not a page which you cannot understand.

**IF you earn your living in the industry,**

this work is worth pounds to you as an ever ready source of reliable information.

Contributors include:

- SIR OLIVER LODGE
- SIR AMBROSE FLEMING
- L. McMICHAEL
- RALPH STRANGER
- J. ROBINSON
- F. HAYNES
- N. ASHBRIDGE
- A. E. WATKINS

And many other experts.

But every article is written in simple language.

**GET YOUR COPY TO-DAY**

Obtainable at all Newsagents and Bookstalls, or post free 1/2 from George Newnes, Ltd., 8-11, Southampton St., Strand, London, W.C.2.

**1/6**



*Graham Farish says:-*

**“DON'T  
WORRY!”**

**Your set's all right”**

All these little troubles are due to a faulty earth. You've made the set carefully but neglected the vital point, the only direct connection to the station—the earth.

Take my advice, fit a Filt to-day—the results will astonish you!

Is your own set giving you the best? You don't know its possibilities until you try a Filt—spend half-a-crown on Filt and give your set a chance.



Simply bury the copper receptacle containing the wonderful FILT chemical, which at once begins to spread through the earth, attracting moisture and making a PERMANENT highly conductive area to the depth of several feet. FILT keeps moist and highly conductive. It spreads like a tentacle, earthing your set perfectly and giving you every ounce of power, range and purity, no matter what set you use.

**GRAHAM FARISH**

**FILT**

**PERCOLATIVE  
EARTH**

Get a Filt to-day from the nearest radio dealer or direct (post free) from the sole manufacturers

**Graham Farish Ltd.**  
201, Masons Hill,  
Bromley, Kent

**2/6**  
**COMPLETE**